

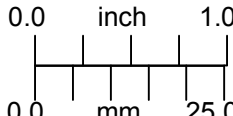

UNLESS OTHERWISE SPECIFIED DIMENSIONS ARE IN INCHES [MM] AND INCLUDE CHEMICALLY APPLIED OR PLATED FINISHES		<b>PROPRIETARY AND CONFIDENTIAL</b>				
SCALE: 1:1		THE INFORMATION CONTAINED IN THIS DRAWING IS THE SOLE PROPERTY OF NAVITAR. ANY REPRODUCTION IN PART OR AS A WHOLE WITHOUT THE WRITTEN PERMISSION OF NAVITAR IS PROHIBITED.				
WEIGHT: 0.44 lbmass		0.0 inch 1.0		6X FLAT MOUNT ASSEMBLY, METRIC		
DR BY: J. WILLIAMSON						
CH BY: C. HATCH		0.0 mm 25.0				
PROJECT #: E3352		DO NOT SCALE DRAWING		SIZE	PART NUMBER	REV
DATE DR: 8/5/2015				<b>A</b>	<b>1-64547</b>	<b>A</b>