

REV	CHANGE RECORD AND DATE	CH
A	RELEASE 10/16/03	

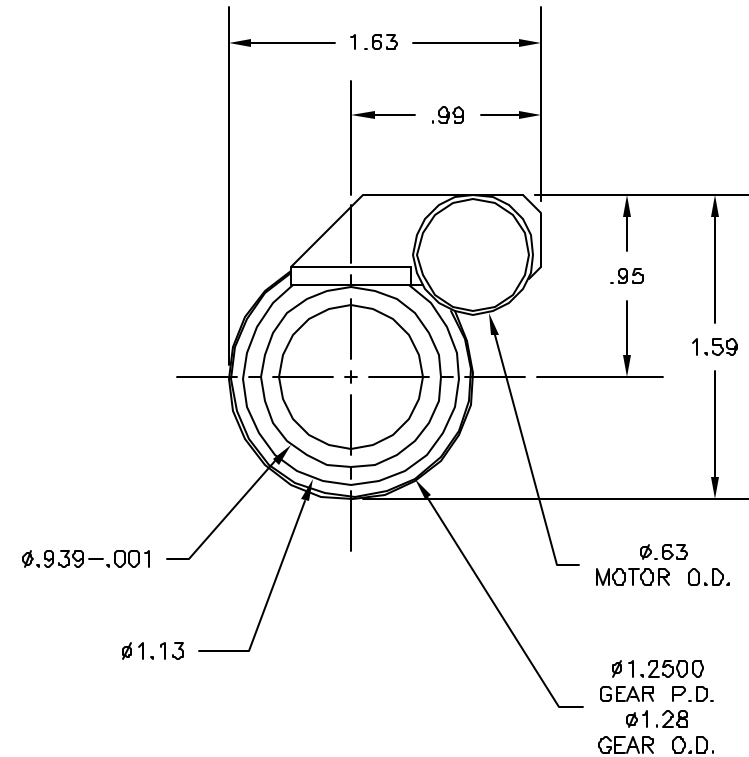
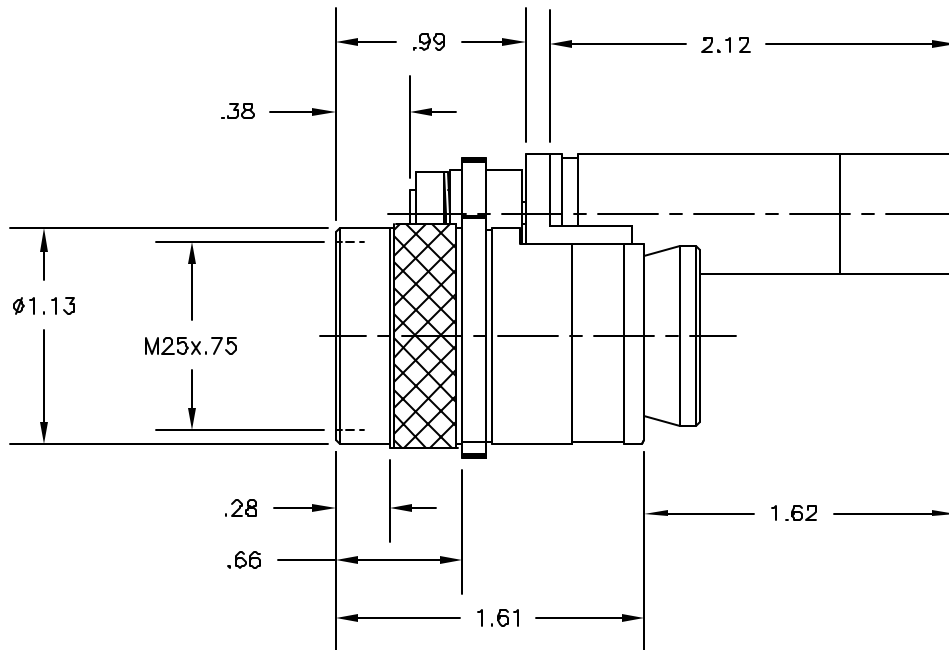

NEXT ASSY.

USED ON

MATERIAL	UNLESS OTHERWISE SPECIFIED DIMENSIONS ARE IN INCHES AND INCLUDE CHEMICALLY APPLIED OR PLATED FINISHES		<u>P/N Suffix Definition</u> -1 Conversion Coating -2 Painting -3 Marking -R Rework			
	TOLERANCES AS FOLLOWS DEC. .XXX ±.005 DEC. .XX ±.010 FRACT. ±1/64 ANGLES ±30° CONCENTRICITY .003 TIR BREAK ALL SHARP EDGES .005 MIN. .010 MAX. MAX. SURF. ROUGHNESS $\sqrt{32}$					SCALE 1:1 DR. PB CH. APP. DATE DR. 10/16/03 DO NOT SCALE DRAWING
FINISH			0.0 inch 1.0  0.0 mm 25.0  	SIZE <b>A</b>	<b>1-62691 OL</b> SHT. 1 OF 1	REV <b>A</b>
CHAMFER ALL THREADS 30° TO ROOT DIAM.						