

REV	CHANGE RECORD AND DATE	CH
A	RELEASE 5/25/98	SSC

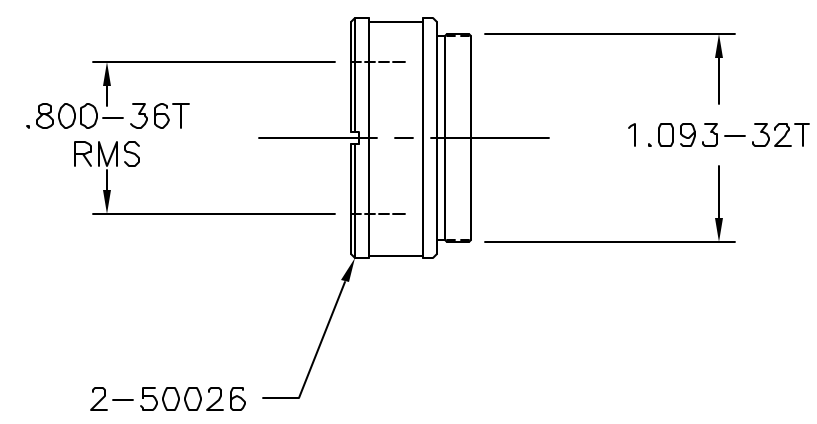
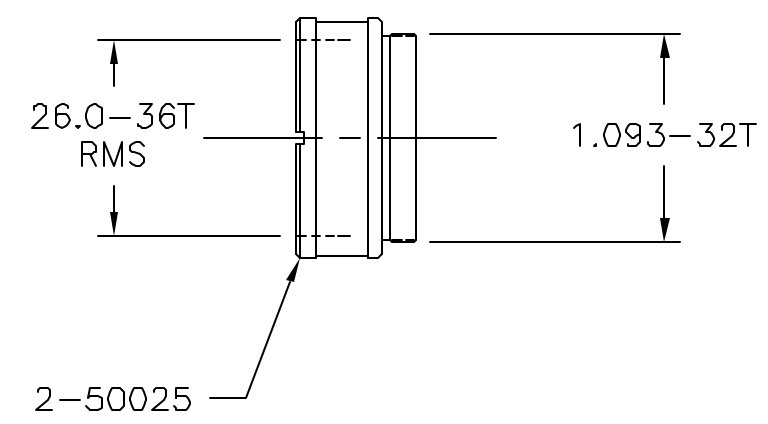
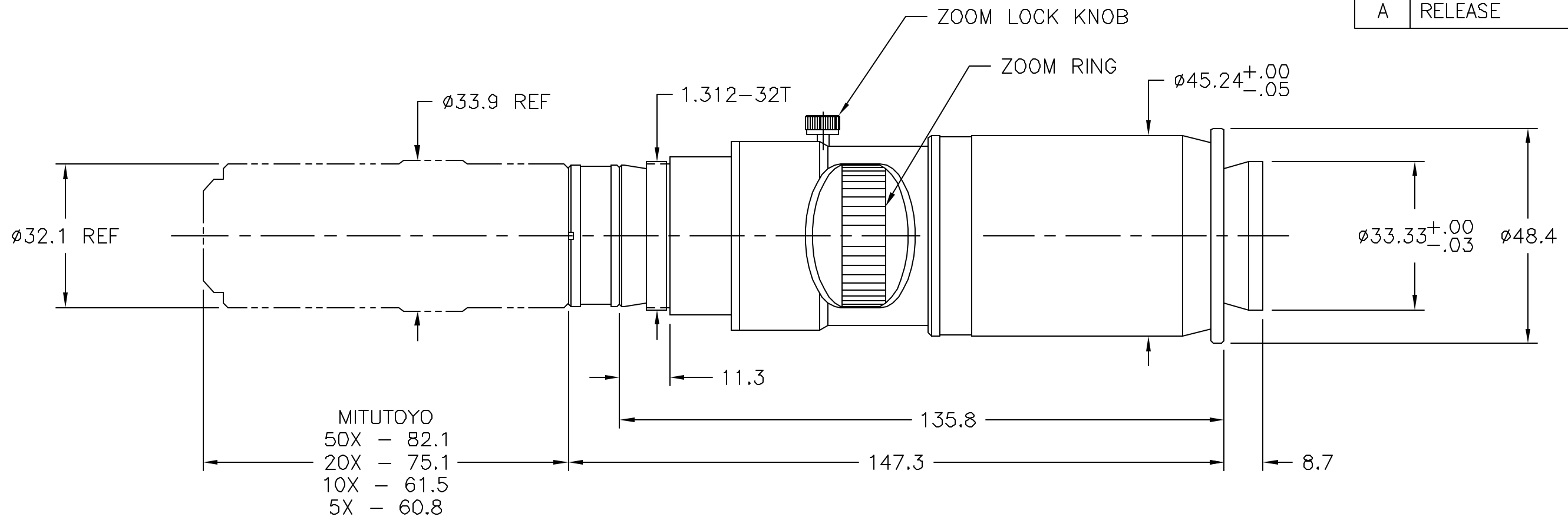

1-50502 OL

NEXT ASSY.

USED ON

MATERIAL	UNLESS OTHERWISE SPECIFIED DIMENSIONS ARE IN MM AND INCLUDE CHEMICALLY APPLIED OR PLATED FINISHES		P/N Suffix Definition -1 Conversion Coating -2 Painting -3 Marking -R Rework		
	TOLERANCES AS FOLLOWS				
FINISH	DEC. .XX	±.10	DR.	SSC	0.0 inch 1.0 
	DEC. .X	±.20	CH.	PB	
CHAMFER ALL THREADS 30° TO ROOT DIAM.	ANGLES	±30'	APP.	-	0.0 mm 25.0 
	CONCENTRICITY	.08 TIR	DATE DR.	9/25/98	
	BREAK ALL SHARP EDGES .15 MIN. .25 MAX.		DO NOT SCALE DRAWING		
	MAX. SURF. ROUGHNESS	√.80			SIZE B 1-50502 OL SHT. 1 OF 1
					REV A