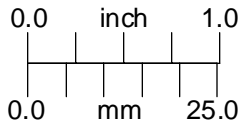
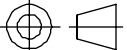

OUTLINE

UNLESS OTHERWISE SPECIFIED DIMENSIONS ARE IN INCHES AND INCLUDE CHEMICALLY APPLIED OR PLATED FINISHES		THE CONTENTS OF THIS DOCUMENT ARE PROPRIETARY TO NAVITAR, ITS USE IS AUTHORIZED ONLY FOR RESPONDING TO REQUEST FOR QUOTATION OR PERFORMANCE OF WORK FOR NAVITAR			
SCALE:	1:1			0.25X LENS ATTACHMENT	
WEIGHT:	.04LBM				
DR:	DJM				
CH:	PB				
PROJECT #:		DO NOT SCALE DRAWING		SIZE	1-50011
DATE DR:	6/19/2003			A	
				SHEET 2 OF 2	
				REV C	