

REVISIONS				
ZONE	REV.	DESCRIPTION	DATE	APPROVED
	A	RENAMED AND REFORMATTED LE250 ASSEMBLY	7/17/2017	

SPANNER SLOT FOR COMPRESSION ADJUSTMENT

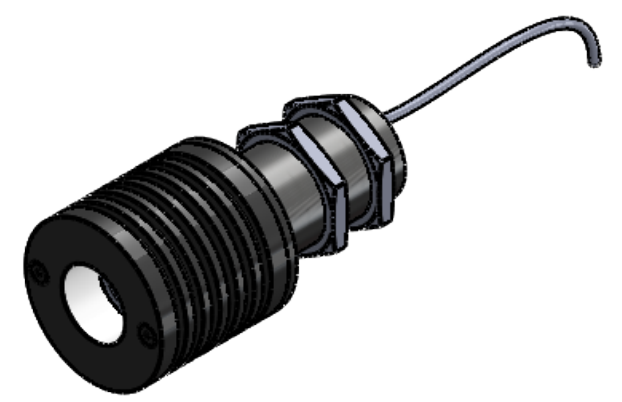

Metaphase Technologies, Inc. 211 Sinclair Road, Suite 100, Bristol, PA. 19007 215-639-8699 Fax 215-639-0977

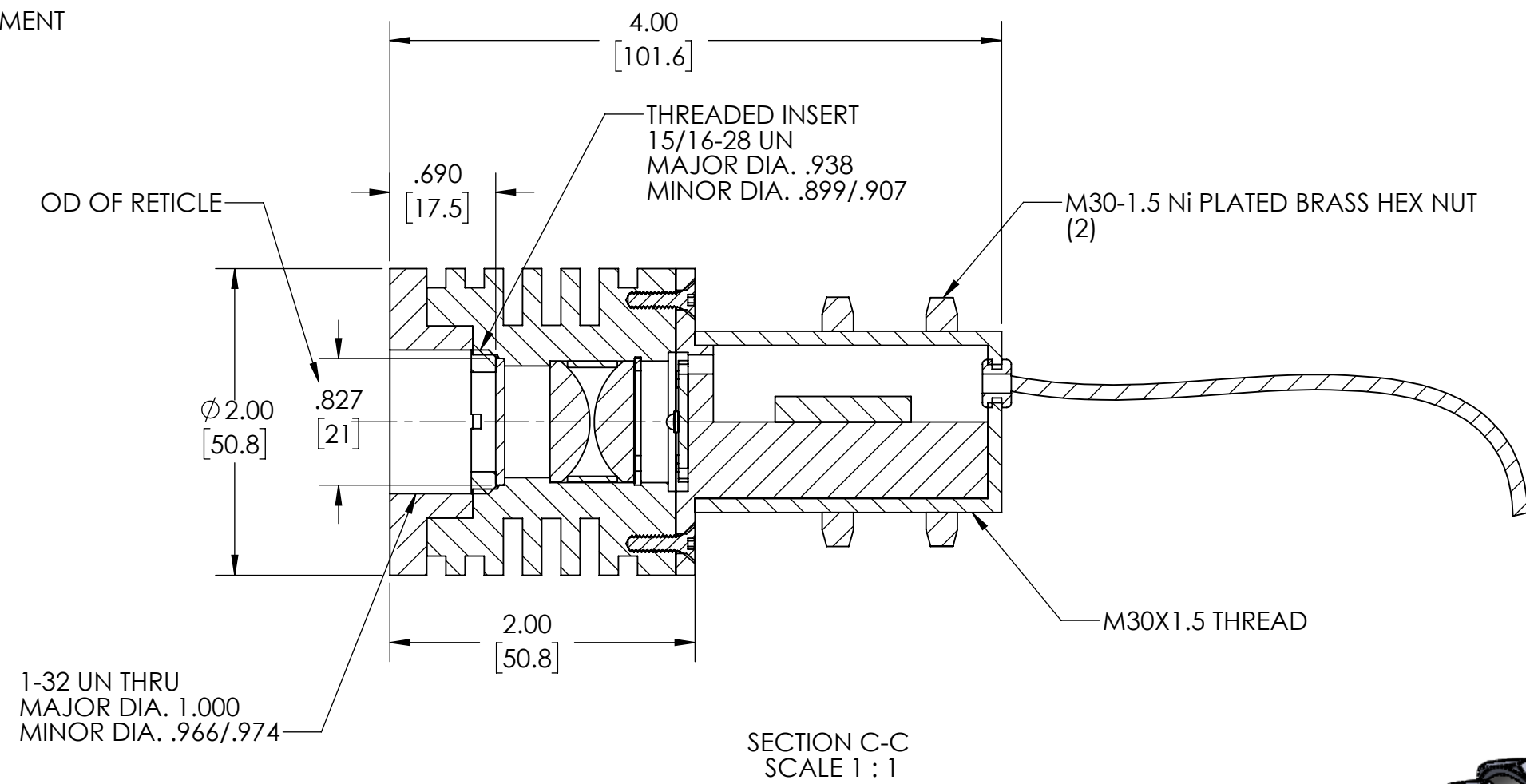
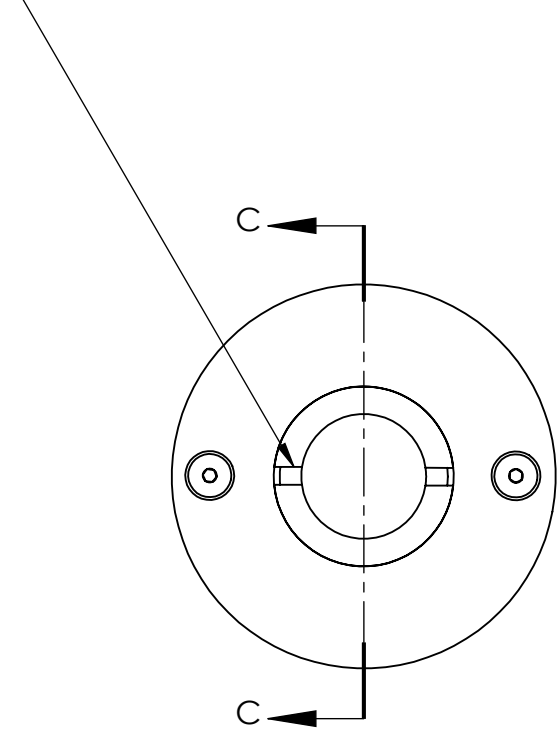

QUANTITY:	Per order	TOLERANCE/FINISH UNLESS OTHERWISE SPECIFIED				THIS DOCUMENT IS THE PROPERTY OF METAPHASE TECHNOLOGIES, INC. WHOM MAY LOAN IT, SUBJECT TO RETURN UPON DEMAND. IT INCLUDES CONFIDENTIAL & PROPRIETARY INFORMATION WHICH MAY NOT BE DISCLOSED TO ANY THIRD PARTY, AND/ OR USED FOR ANY PURPOSE CONTRARY TO IT'S INTENDED USE, WITHOUT THE EXPRESSED PRIOR WRITTEN CONSENT OF METAPHASE TECHNOLOGIES, INC.	
MATERIAL:	Per BOM	INCHES [MM]					
FINISH:	Black Anodize	X	.X	.XX	.XXX		125√RMS [RA3.2um]
TREATMENT:	N/A	[±.76]	±.030 [±.25]	±.010 [±.13]	±.005		ANGLES ±1°

THIS DOCUMENT IS THE PROPERTY OF METAPHASE TECHNOLOGIES, INC. WHOM MAY LOAN IT, SUBJECT TO RETURN UPON DEMAND. IT INCLUDES CONFIDENTIAL & PROPRIETARY INFORMATION WHICH MAY NOT BE DISCLOSED TO ANY THIRD PARTY, AND/ OR USED FOR ANY PURPOSE CONTRARY TO IT'S INTENDED USE, WITHOUT THE EXPRESSED PRIOR WRITTEN CONSENT OF METAPHASE TECHNOLOGIES, INC.

TITLE	ASSEMBLY, HP-LPP		
USED ON	Per customer		
SIZE	DRAWING NUMBER	REV	
B	HP-LPP-01	A	
SCALE 1:2	SHEET 1 OF 1		

Approval Signature _____

/ /
Date