

Size Units (XX or YY)	Ax (mm)	Ay (mm)
02	50	50
03	75	75
04	100	100
05	125	125
06	150	150
07	175	175
08	200	200
09	225	225
10	250	250
11	275	275
12	300	300
13	325	350
14	350	350
15	375	375
16	400	400
XX or YY	XX x 25	XX x 25

One unit of measurement = 25mm of active area

Example: TXBL-ASSY-1020

Length Ax: XX=10 so Ax=10 X 25 = 250mm

Height Ay: YY=20 so Ay=20 x 25 = 500mm

where Total Active Area=Ax x Ay

See sheet 2 for assemblies that require multiple connectors

NOTE: THIS DRAWING PACKET IS FOR REFERENCE ONLY. FOR ACTUAL DIMENSIONS SEE TABLE.

Metaphase Technologies, Inc. 200 Rittenhouse Circle, West Building Unit 7, Bristol, PA. 19007 215-639-8699 Fax 215-639-0977



QUANTITY: PER CUSTOMER

MATERIAL: N/A

FINISH: N/A

TREATMENT: N/A

TOLERANCE / FINISH UNLESS OTHERWISE SPECIFIED

INCHES [MM]				125√RMS [RA3.2um]
X	.X	.XX	.XXX	ANGLES ±1°
[±.76]	±.030 [±.25]	±.010 [±.13]	±.005	

THIS DOCUMENT IS THE PROPERTY OF METAPHASE TECHNOLOGIES, INC. WHOM MAY LOAN IT, SUBJECT TO RETURN UPON DEMAND. IT INCLUDES CONFIDENTIAL & PROPRIETARY INFORMATION WHICH MAY NOT BE DISCLOSED TO ANY THIRD PARTY, AND/ OR USED FOR ANY PURPOSE CONTRARY TO IT'S INTENDED USE, WITHOUT THE EXPRESSED PRIOR WRITTEN CONSENT OF METAPHASE TECHNOLOGIES, INC.

TITLE
TOP ASSY; TX BACKLIGHT

USED ON
PER CUSTOMER

SIZE **B** DRAWING NUMBER **TXBLXXYY** REV **A**

SCALE 1:2 SHEET 1 OF 3

Approval Signature

/ /
Date

Multiple Connector Assembly

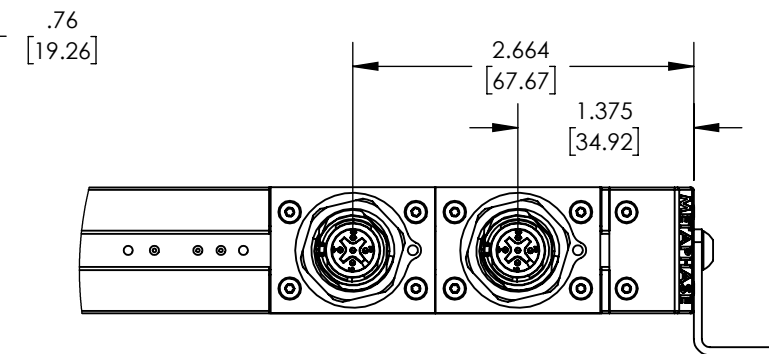
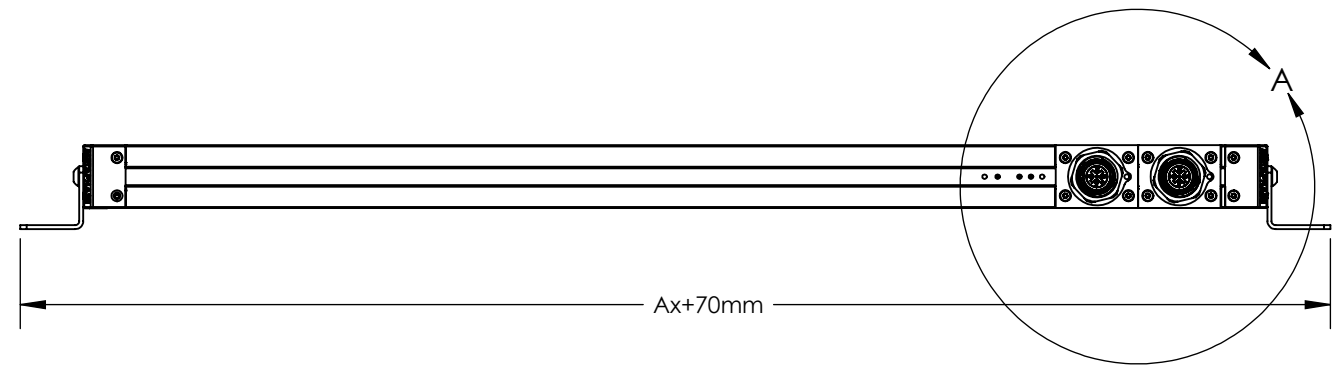
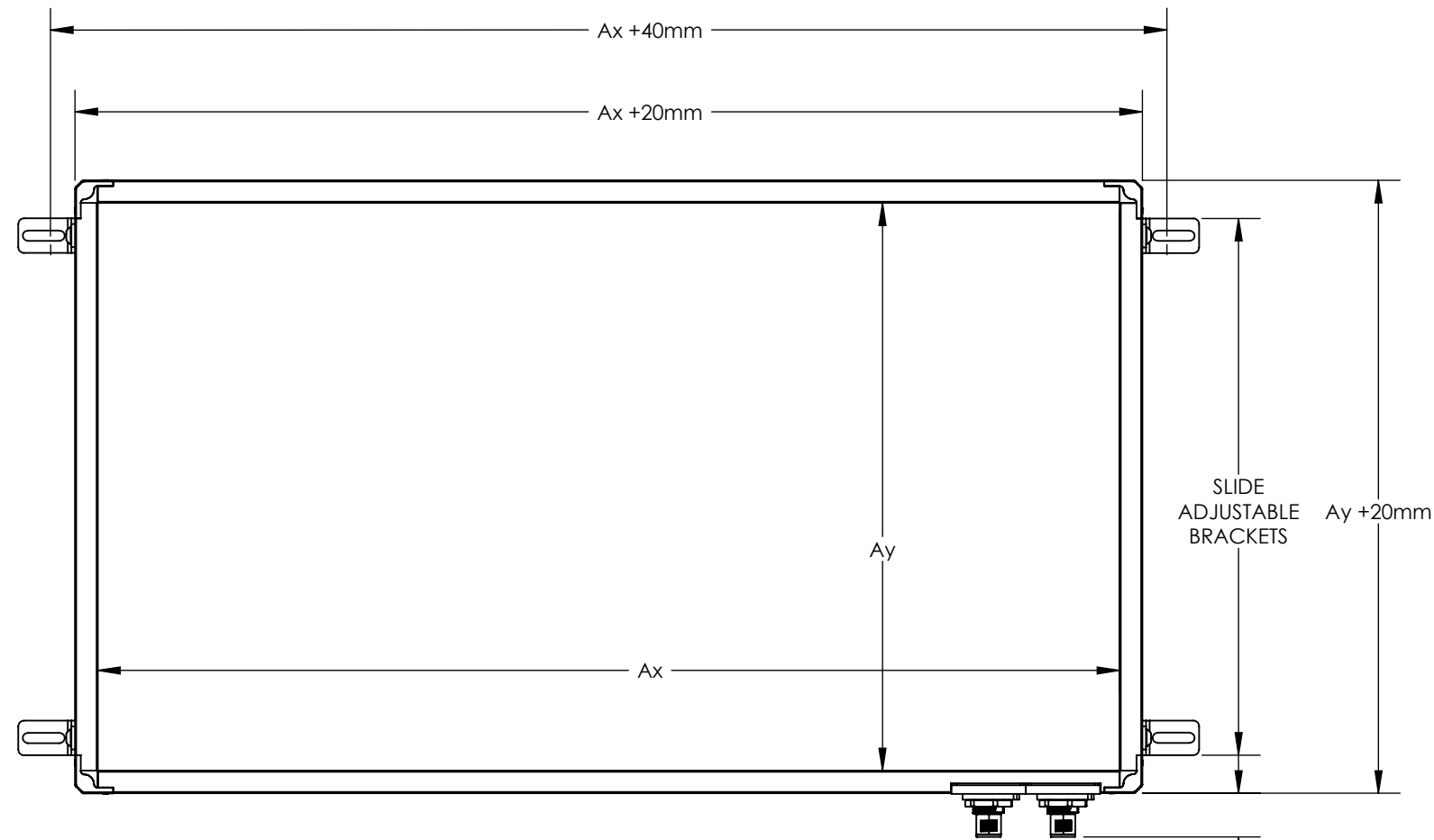

The center of each additional connector will be spaced 1.289" apart.

DETAIL A
SCALE 2 : 3

Metaphase Technologies, Inc. 200 Rittenhouse Circle, West Building Unit 7, Bristol, PA. 19007 215-639-8699 Fax 215-639-0977



TOLERANCE/FINISH UNLESS OTHERWISE SPECIFIED				
INCHES[MM]				125√RMS [RA3.2um]
X	.X	.XX	.XXX	
[±.76]	±.030 [±.25]	±.010 [±.13]	±.005	ANGLES ±1°
FLAT PATTERNS USE 0.5 K FACTOR FOR DESIGN REFERENCE ONLY. ACTUAL VALUE MAY VARY, USE TEST PART AS REQ'D TO VERIFY ACCURACY				

THIS DOCUMENT IS THE PROPERTY OF METAPHASE TECHNOLOGIES, INC. WHOM MAY LOAN IT, SUBJECT TO RETURN UPON DEMAND. IT INCLUDES CONFIDENTIAL & PROPRIETARY INFORMATION WHICH MAY NOT BE DISCLOSED TO ANY THIRD PARTY, AND/ OR USED FOR ANY PURPOSE CONTRARY TO IT'S INTENDED USE, WITHOUT THE EXPRESSED PRIOR WRITTEN CONSENT OF METAPHASE TECHNOLOGIES, INC.

TITLE
TOP ASSY; TX BACKLIGHT

USED ON
PER CUSTOMER

SIZE B	DRAWING NUMBER TXBLXXYY	REV A
SCALE 1:3	SHEET 2 OF 3	

PART NUMBER	Ax (mm)	Ay (mm)
TXBL-ASSY-0101	25	25

PART NUMBER	Ax (mm)	Ay (mm)
TXBL-ASSY-0202	50	50

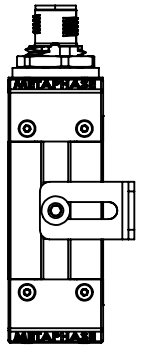
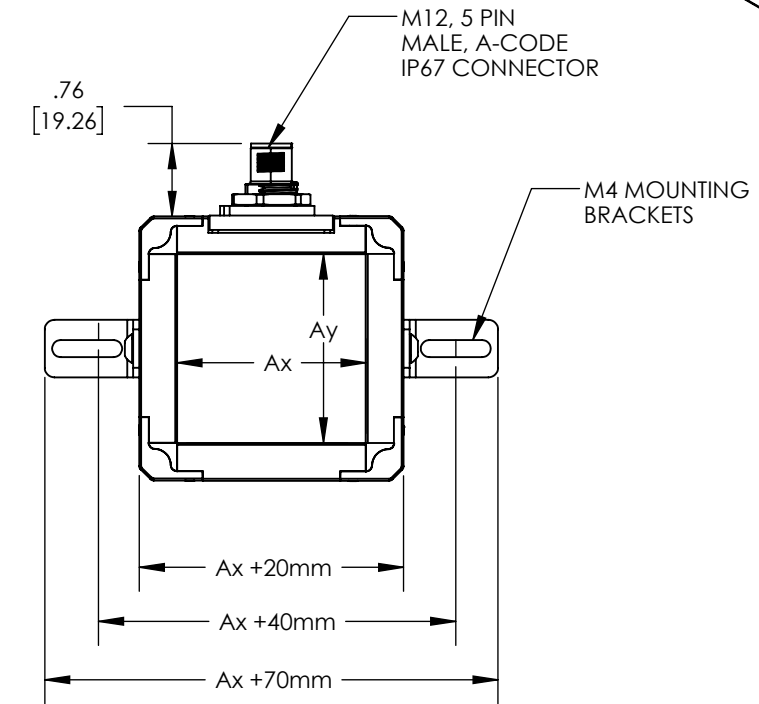
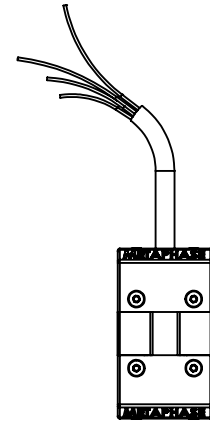
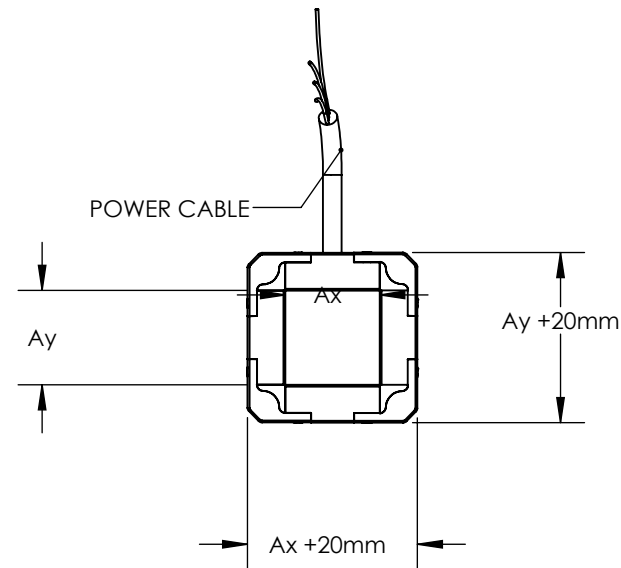
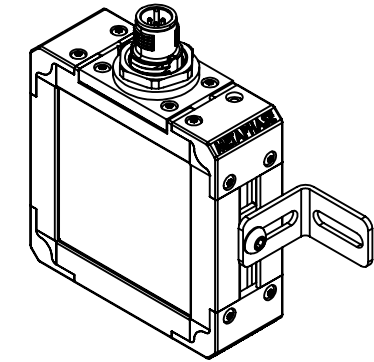
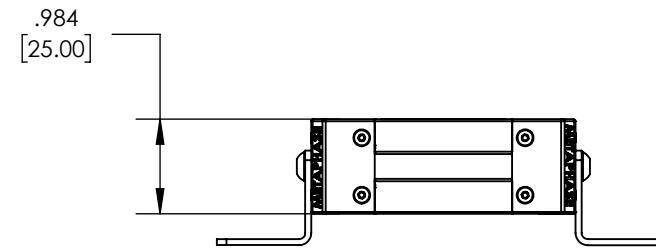
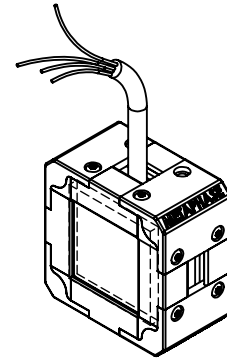
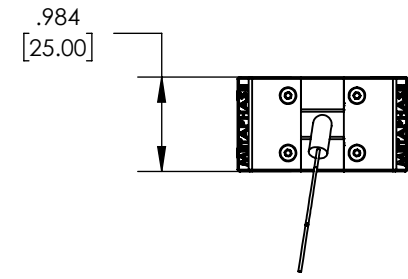

Metaphase Technologies, Inc. 211 Sinclair Road, Suite 100,
Bristol, PA. 19007 215-639-8699 Fax 215-639-0977



TOLERANCE/FINISH
UNLESS OTHERWISE SPECIFIED

X	INCHES[MM]			125√RMS [RA3.2um]
	.X	.XX	.XXX	
[±.76]	±.030 [±.25]	±.010 [±.13]	±.005	ANGLES ±1°

FLAT PATTERNS USE 0.5 K FACTOR FOR DESIGN
REFERENCE ONLY. ACTUAL VALUE MAY VARY,
USE TEST PART AS REQ'D TO VERIFY ACCURACY

THIS DOCUMENT IS THE PROPERTY OF
METAPHASE TECHNOLOGIES, INC. WHOM MAY
LOAN IT, SUBJECT TO RETURN UPON DEMAND.
IT INCLUDES CONFIDENTIAL & PROPRIETARY
INFORMATION WHICH MAY NOT BE DISCLOSED
TO ANY THIRD PARTY, AND/ OR USED FOR
ANY PURPOSE CONTRARY TO IT'S INTENDED
USE, WITHOUT THE EXPRESSED PRIOR WRITTEN
CONSENT OF **METAPHASE TECHNOLOGIES, INC.**

TITLE
TOP ASSY; TX BACKLIGHT

USED ON
PER CUSTOMER

SIZE	DRAWING NUMBER	REV
B	TXBLXXYY	A
SCALE	1:2	SHEET 3 OF 3