

VL series

User Manual

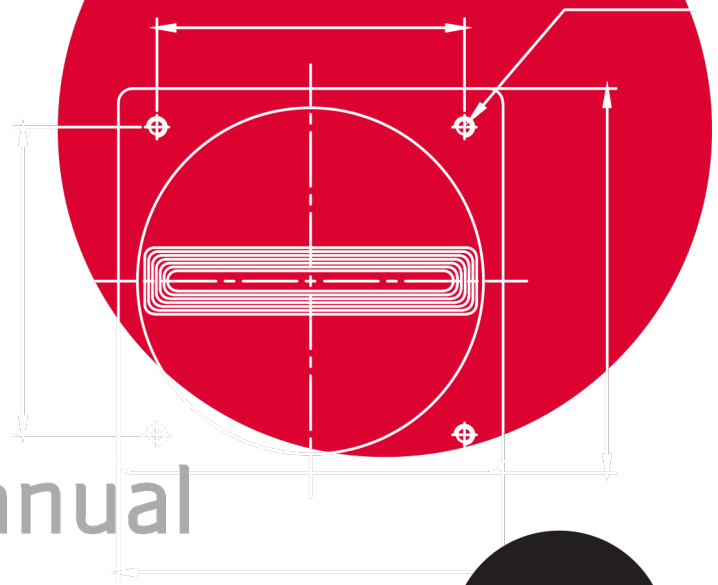

English

VL-8K7C-M80F-2
VL-16K3.5C-M50F-1

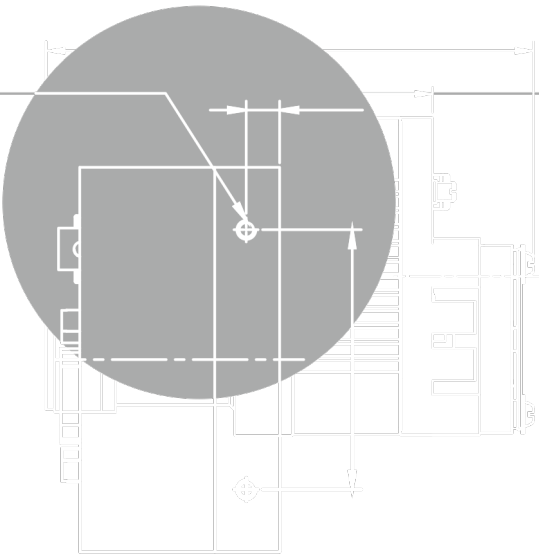

VIEWWORKS

Revision History

Version	Date	Description
1.0	2014-02-14	Initial release
1.1	2014-09-19	Applied new CI
1.2	2016-04-22	Added typical power requirements
1.3	2020-06-11	<ul style="list-style-type: none">Applied new CIChanged the pixel formats available with the Camera Link output modesAdded support for 50 MHz, 60 MHz and 70 MHz Camera Link Pixel Clock
1.4		<ul style="list-style-type: none">Added QE graph
1.5	2021-08-06	<ul style="list-style-type: none">Applied new model nameAdded 10 Tap functionModified Max. Line rate
1.6	2021-11-11	<ul style="list-style-type: none">Modified Max. Line rateModified the temperature of the camera housingModified the description on the Command List table
1.7	2021-11-25	Deleted the description on the LUT function
1.8	2021-12-30	Modified the description on the Target Level for the PRNU correction

Contents

1	Precautions	5
2	Warranty	7
3	Compliance & Certifications	7
3.1	FCC Compliance	7
3.2	CE : DoC	7
3.3	KC	7
4	Package Components	8
5	Product Specifications	9
5.1	Overview	9
5.2	Specifications	10
5.3	Camera Block Diagram	12
5.4	Spectral Response and Quantum Efficiency	13
5.5	Mechanical Specification	14
5.5.1	Camera Mounting and Heat Dissipation	14
6	Connecting the Camera	15
6.1	Precaution to Center the Image Sensor	15
6.2	Controlling the Camera	15
7	Camera Interface	16
7.1	General Description	16
7.2	Camera Link MDR Connector	16
7.3	Power Input Receptacle	19
7.4	Control Receptacle	20
7.5	Trigger Input Circuit	21
7.6	Strobe Output Circuit	21
8	Camera Features	22
8.1	Region of Interest	22
8.1.1	Setting the ROI	22
8.2	Image Mode (VL-8K7C-M80F-2 Only)	23
8.2.1	Single Line	24
8.2.2	Dual Line	24
8.2.3	Binning	26
8.3	Trigger Mode	28
8.3.1	Free-Run	28

8.3.2	External Sync	29
8.3.3	External Sync Converter	31
8.4	Camera Link Output	32
8.5	Data Bit	33
8.6	Gain and Offset	34
8.7	Test Image.....	34
8.8	Dark Signal Non-uniformity Correction.....	35
8.8.1	Generating and Saving User DSNU Correction Values	35
8.9	Photo Response Non-uniformity Correction.....	37
8.9.1	Generating and Saving User PRNU Correction Values	37
8.10	Temperature Monitor	40
8.11	Status LED	40
8.12	Horizontal Flip	41
8.13	Strobe Out.....	42
8.14	Field Upgrade.....	42
9	Camera Configuration	43
9.1	Setup Command	43
9.2	User Set Control.....	45
9.3	Command List	46
10	Configurator GUI.....	49
10.1	Camera Scan	49
10.2	Menu	50
10.2.1	File.....	50
10.3	Start-Up.....	51
10.3.1	Tool.....	52
10.3.2	About	53
10.4	Tab	54
10.4.1	VIEW Tab.....	54
10.4.2	MODE/EXP Tab.....	55
10.4.3	GAIN Tab	56
11	Troubleshooting.....	57
Appendix A	Field Upgrade	58
A.1	MCU	58
A.2	FPGA	61

1 Precautions

General



- Do not drop, disassemble, repair or alter the device. Doing so may damage the camera electronics and cause an electric shock.
- Do not let children touch the device without supervision.
- Stop using the device and contact the nearest dealer or manufacturer for technical assistance if liquid such as water, drinks or chemicals gets into the device.
- Do not touch the device with wet hands. Doing so may cause an electric shock.
- Make sure that the temperature of the camera does not exceed the temperature range specified in [5.2 Specifications](#). Otherwise the device may be damaged by extreme temperature.

Installation and Maintenance



- Do not install in dusty or dirty areas - or near an air conditioner or heater to reduce the risk of damage to the device.
- Avoid installing and operating in an extreme environment where vibration, heat, humidity, dust, strong magnetic fields, explosive/corrosive mists or gases are present.
- Do not apply excessive vibration and shock to the device. This may damage the device.
- Avoid direct exposure to a high intensity light source. This may damage the image sensor.
- Do not install the device under unstable lighting conditions. Severe lighting change will affect the quality of the image produced by the device.
- Do not use solvents or thinners to clean the surface of the device. This can damage the surface finish.

Power Supply



- Applying incorrect power can damage the camera. If the voltage applied to the camera is greater or less than the camera's nominal voltage, the camera may be damaged or operate erratically. Please refer to [5.2 Specifications](#) for the camera's nominal voltage.
 - ※ Vieworks Co., Ltd. does NOT provide power supplies with the devices.
- Make sure the power is turned off before connecting the power cord to the camera. Otherwise, damage to the camera may result.

Cleaning the Sensor Surface

Avoid cleaning the surface of the camera's sensor if possible. If you have dust or foreign matter on the sensor surface that will not blow off, use a soft lint free cotton bud dampened with a small quantity of high quality lens cleaner. Because electrostatic discharge (ESD) can damage the sensor, you must use a cloth (e.g. cotton) that will not generate static during cleaning.



Avoid dust or foreign matter on the sensor surface.

The camera is shipped with a protective plastic seal on the camera front. To prevent collecting dust or foreign matter on the camera sensor, make sure that you always put the protective seal in place when there is no lens mounted on the camera. In addition, make sure to always point the camera downward when there is no protective seal on the camera front or no lens mounted.

Procedures for Cleaning the Sensor

If you have dust or foreign matter on the sensor surface, follow the procedures below to wipe off.

1. Remove a contaminant by using an ionizing air gun.
If this step does not remove the contaminant, proceed to the next step.
2. Clean the contaminant on the sensor using one drop of lens cleaner on a non-fluffy cotton bud.
3. Wipe the cotton bud gently in only one direction (either left to right or right to left). Avoid wiping back and forth with the same cotton bud in order to ensure that the contaminants are removed and not simply transferred to a new location on the sensor surface.
4. Mount a lens, set the lens at a smaller aperture (e.g. F8), and then acquire images under bright lighting conditions. Check the images on the monitor for dark spots or stripes caused by the contaminant. Repeat the steps above until there is no contaminant present.



If the sensor is damaged due to electrostatic discharge or the sensor surface is scratched during cleaning, the warranty is void.

2 Warranty

Do not open the housing of the camera. The warranty becomes void if the housing is opened.
For information about the warranty, please contact your local dealer or factory representative.

3 Compliance & Certifications

3.1 FCC Compliance

This equipment has been tested and found to comply with the limits for a Class A digital device, pursuant to part 15 of the FCC Rules. These limits are designed to provide reasonable protection against harmful interference when the equipment is operated in a commercial environment. This equipment generates, uses, and can radiate radio frequency energy and, if not installed and used in accordance with the instruction manual, may cause harmful interference to radio communications. Operation of this equipment in a residential area is likely to cause harmful interference in which case the user will be required to correct the interference at his own expenses.

3.2 CE : DoC

EMC Directive 2014/30/EU
EN 55032:2012 (Class A), EN 55024:2010
Class A

3.3 KC

KCC Statement

Type	Description
Class A (Broadcasting Communication Device for Office Use)	This device obtained EMC registration for office use (Class A), and may be used in places other than home. Sellers and/or users need to take note of this.

4 Package Components

Package Components



VL Camera with M72 × 0.75 mount

5 Product Specifications

5.1 Overview

VL series is a line scan camera equipped with a CMOS sensor which provides high resolution and fast line rate. It realizes a wide dynamic range beyond a CCD sensor and provides not only high reliability but also high performance required in the machine vision systems. In addition, the VL series includes the following features required by various line scan applications:

Main Features

- CMOS Line Scan
- Max. 16 K Pixel Resolution
- 8 K Double Integration Mode (VL-8K7C-M80F-2)
- 100% Fill Factor
- Exposure Control
- 100× Anti-blooming
- Camera Link Interface (Full Configuration)
- Programmable User Setting Commands
- Pre-emphasis Function (Up to 10 meters at 85 MHz Pixel Clock)
- Field Update Firmware by Configuration Tool
- DSNU/PRNU Correction
- Adjustable Gain and Offset
- Test Pattern

Applications

- Flat Panel Display Inspection
- Printed Circuit Board Inspection
- Parcel Sorting
- Document Scanning
- High Throughput Screening
- Printing/Packaging System

5.2 Specifications

Technical specifications for the VL series are as follows.

Specification		VL-8K7C-M80F-2	VL-16K3.5C-M40F-1
Active Image (H × V)		8192 × 2	16384 × 1
Sensor (AMS)		Dragster DR-2x8k-7 Monochrome Linear CMOS	Dragster DR-16k-3.5 Monochrome Linear CMOS
Pixel Size		7.0 μm × 7.0 μm	3.5 μm × 3.5 μm
Max. Line Rate	2 Tap	20.37 kHz	10.00 kHz
	4 Tap	40.03 kHz	20.00 kHz
	8 Tap	80.00 kHz	40.00 kHz
	10 Tap	-	50.00 kHz
Camera Link Pixel Clock		50 / 60 / 70 / 85 MHz	
Video Output		2, 4, 8 or 10 Tap Output	
Data Format		8 bit (2 / 4 / 8 Tap), 10 bit (2 / 4 Tap) or 12 bit (2 / 4 Tap)	
Dynamic Range		66 dB	64 dB
Max. SNR		45 dB	43 dB
Dark Noise		13 e-	11 e-
Image Direction		CC3 or Programmable	N/A
Dual Line Mode		Supported	N/A
Trigger Mode		Free-Run, External Sync, External Sync Converter	
Trigger Source		External or CC1	
Exposure Time		2.00 ~ 10000.00 μs (0.01 μs step)	
Line Period	2 Tap	49.09 ~ 10000.00 μs	100.00 ~ 10000.00 μs
	4 Tap	24.98 ~ 10000.00 μs	50.00 ~ 10000.00 μs
	8 Tap	12.92 ~ 10000.00 μs	25.00 ~ 10000.00 μs
Black Level		0 ~ 2048 LSB at 12 bits	
Gain Control		Digital Gain: 1.00× ~ 32.00×	
Camera Interface		Camera Link (Base/Medium/Full)	
Max. Cable Length		10 m (@ 85 MHz, Standard CL Cable)	
External Trigger		External, 3.3 V – 5.0 V	
Software Trigger		Camera Link CC1, Programmable Exposure	

Table 5.1 Specifications of VL Series (continuous)

Specification		VL-8K7C-M80F-2	VL-16K3.5C-M40F-1
Lens Mount		M72 × 0.75 mm (Sensor to Camera Front: 12 mm)	
Power	External	8 ~ 28 V DC	
	Dissipation	Typ. 8.0 W	
Environmental		Ambient Operating: 0°C ~ 40°C (Housing: 10°C ~ 50°C), Storage: -40°C ~ 70°C	
Mechanical		80 mm × 80 mm × 54 mm, 420 g	

Table 5.2 Specifications of VL Series

5.3 Camera Block Diagram

VL series consists of three printed circuit boards (PCB), and its block diagram is shown below.

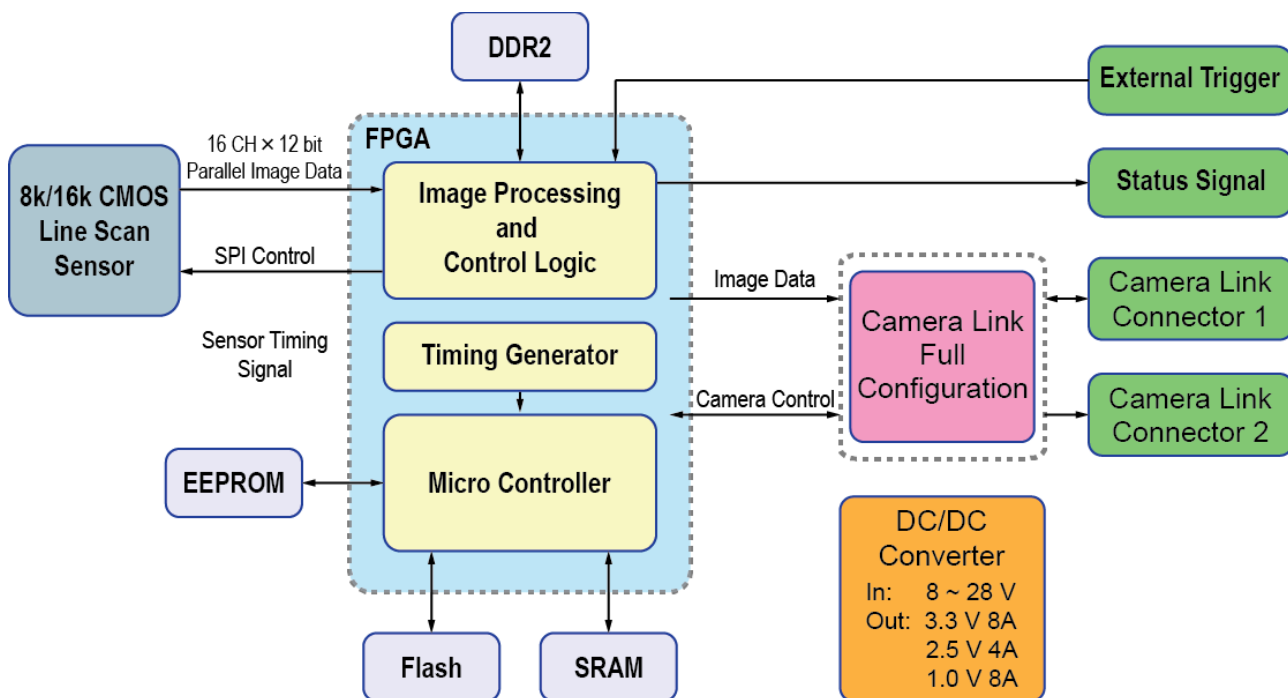

Figure 5.1 Camera Block Diagram

5.4 Spectral Response and Quantum Efficiency

The following graphs show the spectral response and quantum efficiency for VL series.

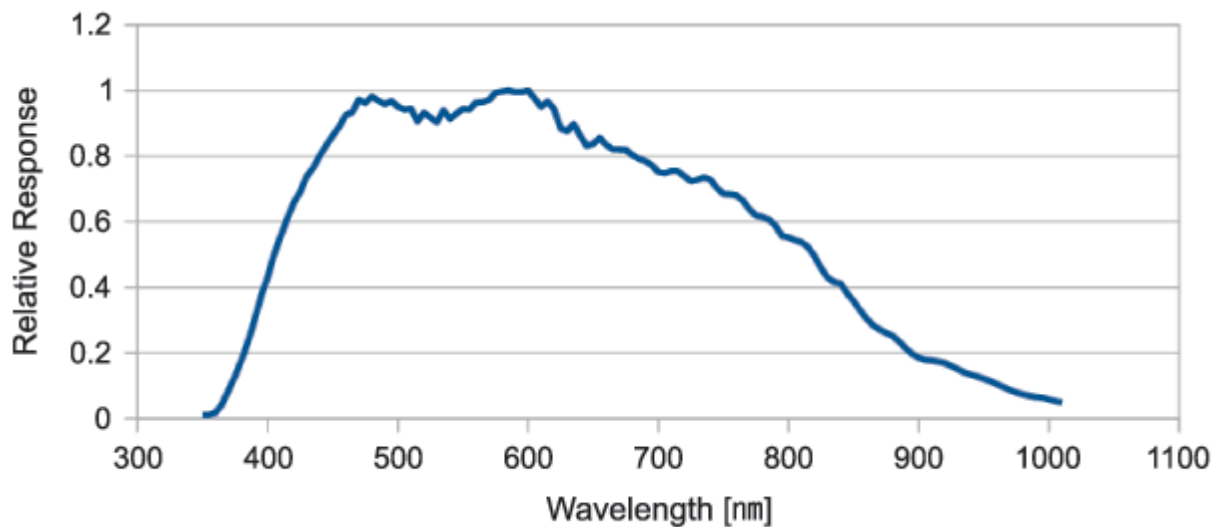

Figure 5.2 Spectral Response (Monochrome)

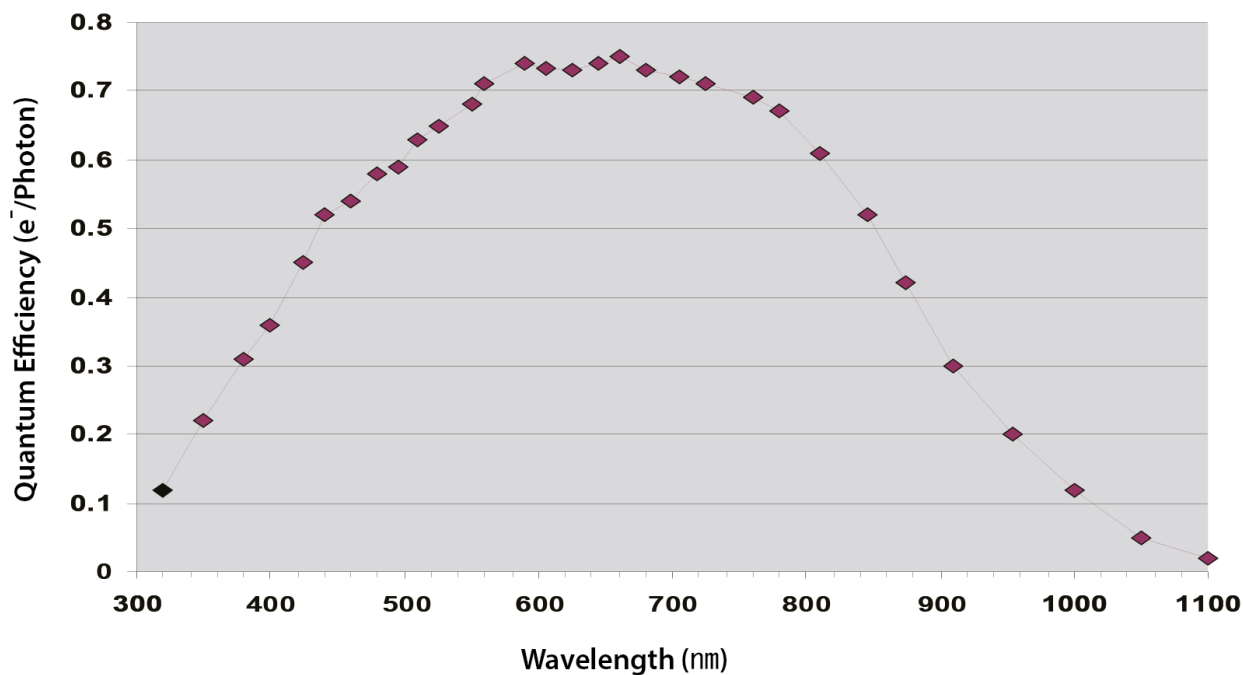

Figure 5.3 Quantum Efficiency

5.5 Mechanical Specification

The camera dimensions in millimeters are shown in the following figure.

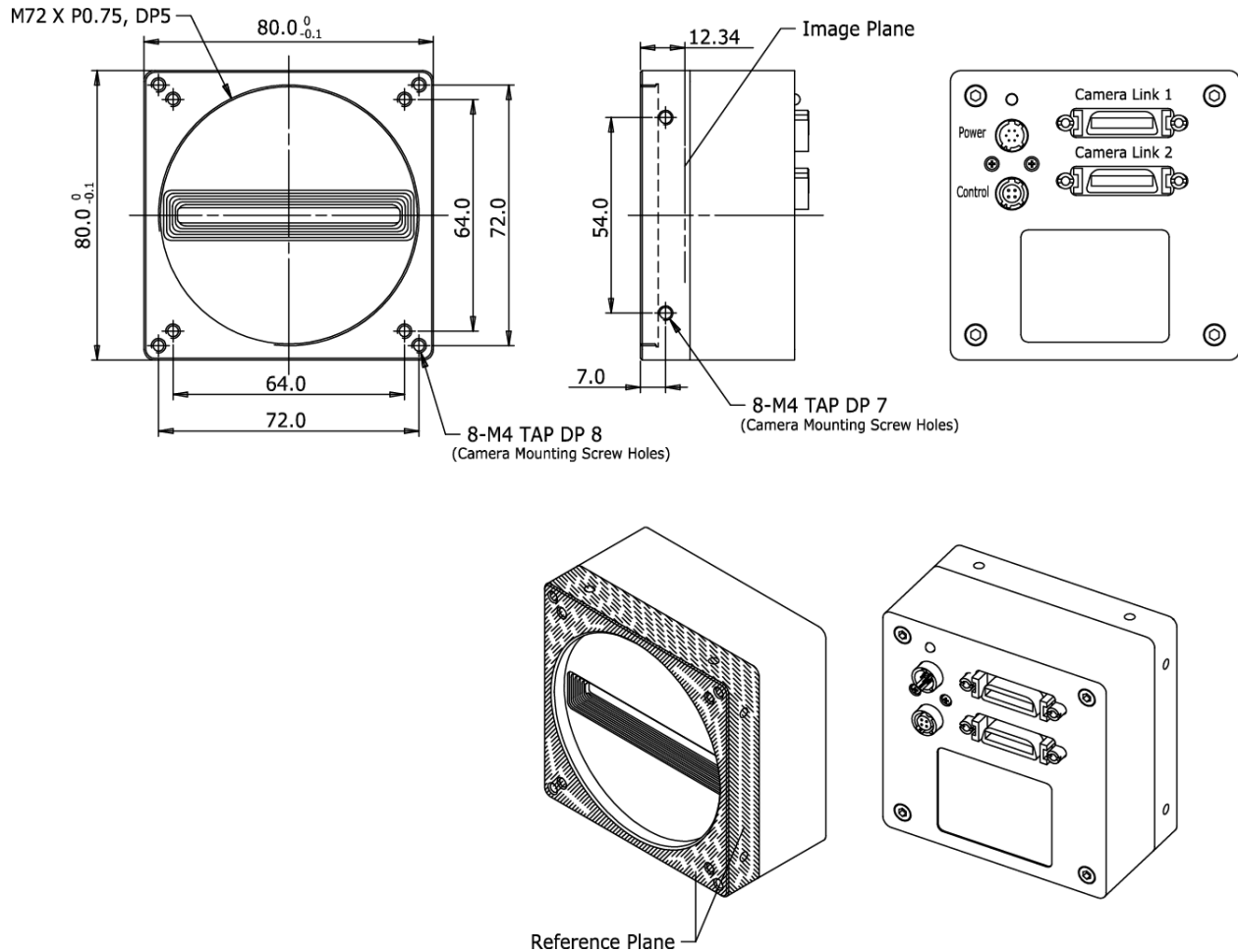

Figure 5.4 VL Series Mechanical Dimension

5.5.1 Camera Mounting and Heat Dissipation

You must mount the camera on a heat dissipation structure to maintain the temperature of the camera housing at 50°C or less. Given the low power consumption of the VL series camera, its housing temperature during operation will generally stay within the specified limits. However, overheating can occur if heat dissipation is restricted or if the camera is mounted on a severe environment. It is recommended to follow the general guidelines below when you mount the camera.

- In all cases, you should monitor the temperature of the camera housing and make sure that the temperature does not exceed 50°C. You can monitor the internal temperature of the camera by using the 'gct' command.
- If your camera is mounted on a metal component in your system, this may provide sufficient heat dissipation.

6 Connecting the Camera

The following instructions assume that you have installed a Camera Link frame grabber in your PC including related software. For more information, refer to your Camera Link frame grabber User Manual.

To connect the camera to your PC, follow the steps below.

1. Make sure that the power supply is not connected to the camera and your PC is turned off.



In the following step, you will be removing the protective plastic seal from the camera front.

To prevent collecting dust or foreign matter on the camera sensor, make sure that the camera is pointing down when you remove the seal.

2. Remove the protective seal from the camera front and mount a lens on the camera.
3. Plug one end of a Camera Link cable into the Camera Link connector on the camera and the other end of the Camera Link cable into the Camera Link frame grabber in your PC.
4. Connect the plug of the power adaptor to the power input receptacle on the camera.
5. Plug the power adaptor into a working electrical outlet.
6. Verify all the cable connections are secure.

6.1 Precaution to Center the Image Sensor

- Users do not need to center the image sensor as it is adjusted as factory default settings.
- When you need to adjust the center of the image sensor, please contact your local dealer or the manufacturer for technical assistance.

6.2 Controlling the Camera

- You can control the camera by executing the Configurator.exe file.
- You can download the latest Configurator at <http://www.viewworks.com>.
- Please refer to your Camera Link frame grabber user manual.

7 Camera Interface

7.1 General Description

As shown in the following figure, four types of connectors and a status indicator LED are located on the back of the camera and have the functions as follows:

- ① 26-pin MDR Connector 1 (Camera Link Base): transmits video data and controls the camera.
- ② 26-pin MDR Connector 2 (Camera Link Medium/Full): transmits video data.
- ③ Status LED:
- ④ 6-pin Power Input Receptacle: supplies power to the camera.
- ⑤ 4-pin Control Receptacle: inputs external trigger signals and outputs strobe signals.

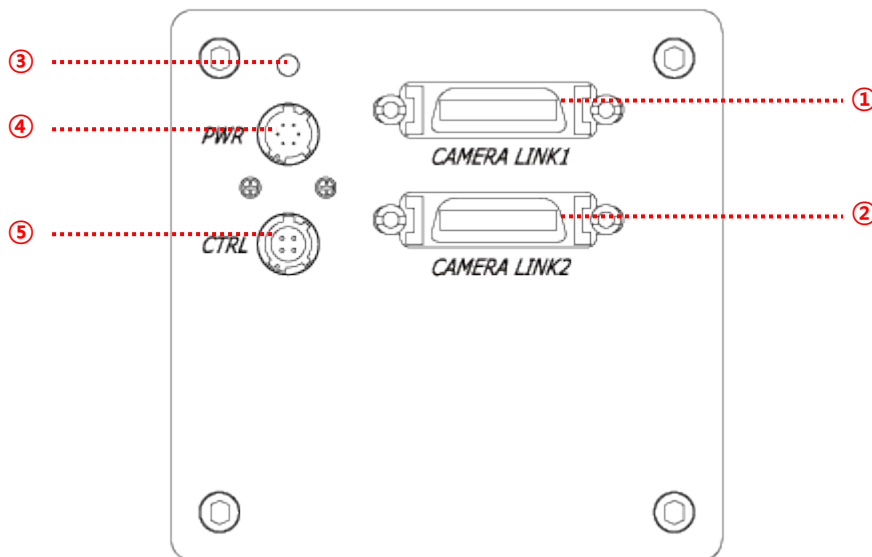

Figure 7.1 VL Series Back Panel

7.2 Camera Link MDR Connector

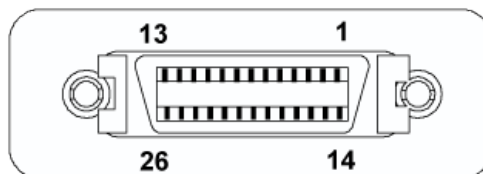

Figure 7.2 26-pin Camera Link MDR Connector

The Camera Link connectors on the camera comply with Camera Link standard and the following table shows the pin assignments.

PAIR List	Pin	Signal Name	Type	Description
PAIR 0	1	Ground	Ground	Cable Shield
	14	Ground	Ground	Cable Shield
PAIR 1	2	-X0	LVDS - Out	Camera Link Transmitter
	15	+X0	LVDS - Out	Camera Link Transmitter
PAIR 2	3	-X1	LVDS - Out	Camera Link Transmitter
	16	+X1	LVDS - Out	Camera Link Transmitter
PAIR 3	4	-X2	LVDS - Out	Camera Link Transmitter
	17	+X2	LVDS - Out	Camera Link Transmitter
PAIR 4	5	-XCLK	LVDS - Out	Camera Link Transmitter
	18	+XCLK	LVDS - Out	Camera Link Transmitter
PAIR 5	6	-X3	LVDS - Out	Camera Link Transmitter
	19	+X3	LVDS - Out	Camera Link Transmitter
PAIR 6	7	+ SerTC	LVDS - In	Serial Data Receiver
	20	- SerTC	LVDS - In	Serial Data Receiver
PAIR 7	8	- SerTFG	LVDS - Out	Serial Data Transmitter
	21	+ SerTFG	LVDS - Out	Serial Data Transmitter
PAIR 8	9	- CC 1	LVDS - In	Software External Trigger
	22	+ CC 1	LVDS - In	Software External Trigger
PAIR 9	10	- CC 2	LVDS - In	N/A
	23	+ CC 2	LVDS - In	N/A
PAIR 10	11	- CC 3	LVDS - In	Image Direction
	24	+ CC 3	LVDS - In	Image Direction
PAIR 11	12	- CC 4	LVDS - In	N/A
	25	+ CC 4	LVDS - In	N/A
PAIR 12	13	Ground	Ground	Cable Shield
	26	Ground	Ground	Cable Shield

Table 7.1 Pin Assignments for Camera Link Connector 1

PAIR List	Pin	Signal Name	Type	Description
PAIR 0	1	Ground	Ground	Cable Shield
	14	Ground	Ground	Cable Shield
PAIR 1	2	-Y0	LVDS - Out	Camera Link Transmitter
	15	+Y0	LVDS - Out	Camera Link Transmitter
PAIR 2	3	-Y1	LVDS - Out	Camera Link Transmitter
	16	+Y1	LVDS - Out	Camera Link Transmitter
PAIR 3	4	-Y2	LVDS - Out	Camera Link Transmitter
	17	+Y2	LVDS - Out	Camera Link Transmitter
PAIR 4	5	-YCLK	LVDS - Out	Camera Link Transmitter
	18	+YCLK	LVDS - Out	Camera Link Clock Tx
PAIR 5	6	-Y3	LVDS - Out	Camera Link Channel Tx
	19	+Y3	LVDS - Out	Camera Link Channel Tx
PAIR 6	7	-	Not Used	Connected with 100 ohm
	20	-	Not Used	
PAIR 7	8	-Z0	LVDS - Out	Camera Link Transmitter
	21	+Z0	LVDS - Out	Camera Link Transmitter
PAIR 8	9	-Z1	LVDS - Out	Camera Link Transmitter
	22	+Z1	LVDS - Out	Camera Link Transmitter
PAIR 9	10	-Z2	LVDS - Out	Camera Link Transmitter
	23	+Z2	LVDS - Out	Camera Link Transmitter
PAIR 10	11	-ZCLK	LVDS - Out	Camera Link Transmitter
	24	+ZCLK	LVDS - Out	Camera Link Clock Tx
PAIR 11	12	-Z3	LVDS - Out	Camera Link Channel Tx
	25	+Z3	LVDS - Out	Camera Link Channel Tx
PAIR 12	13	Ground	Ground	Cable Shield
	26	Ground	Ground	Cable Shield

Table 7.2 Pin Assignments for Camera Link 2 Connector



Generally, Camera Link cables of up to 10 meters length can be used for the VL series camera. However, the maximum usable cable length may be decreased depending on the quality of the Camera Link cables.

7.3 Power Input Receptacle

The power input receptacle is a Hirose 6-pin connector (part # HR10A-7R-6PB). The pin assignments and configurations are as follows:

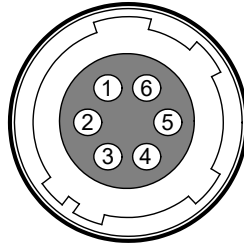

Figure 7.3 Pin Assignments for Power Input Receptacle

Pin Number	Signal	Type	Description
1, 2, 3	+ 12V DC	Input	DC Power Input
4, 5, 6	DC Ground	Input	DC Ground

Table 7.3 Pin Configurations for Power Input Receptacle



- A recommended mating connector for the Hirose 6-pin connector is the Hirose 6-pin plug (part # HR10A-7P-6S) or the equivalent.
- It is recommended that you use the power adapter, which has at least 3 A current output at 12 V DC $\pm 10\%$ voltage output (You need to purchase a power adapter separately.).

Precaution for Power Input



- Make sure the power is turned off before connecting the power cord to the camera. Otherwise, damage to the camera may result.
- If the voltage applied to the camera is greater than specified in the specifications, damage to the camera may result.

7.4 Control Receptacle

The control receptacle is a Hirose 4-pin connector (part # HR10A-7R-4S) and consists of an external trigger signal input and strobe output ports. The pin assignments and configurations are as follows:

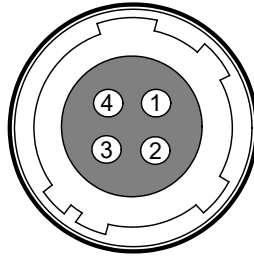

Figure 7.4 Pin Assignments for Control Receptacle

Pin Number	Signal	Type	Description
1	Trigger Input +	Input	3.3 V ~ 5.0 V TTL input Input resistance: 1 k Ω
2	Trigger Input -	Input	DC Ground
3	DC Ground	-	DC Ground
4	Strobe Out	Output	3.3 V TTL Output Output resistance: 47 Ω

Table 7.4 Pin Configurations for Control Receptacle



A recommended mating connector for the Hirose 4-pin connector is the Hirose 4-pin plug (part # HR10A-7P-4P) or the equivalent.

7.5 Trigger Input Circuit

The following figure shows a trigger signal input circuit of the 4-pin connector. Transmitted trigger signal is applied to the internal circuit through a photo coupler. The minimum trigger width that can be recognized by the camera is 1 μ s. If transmitted trigger signal is less than 1 μ s, the camera will ignore the trigger signal.

An external trigger circuit example is shown below.

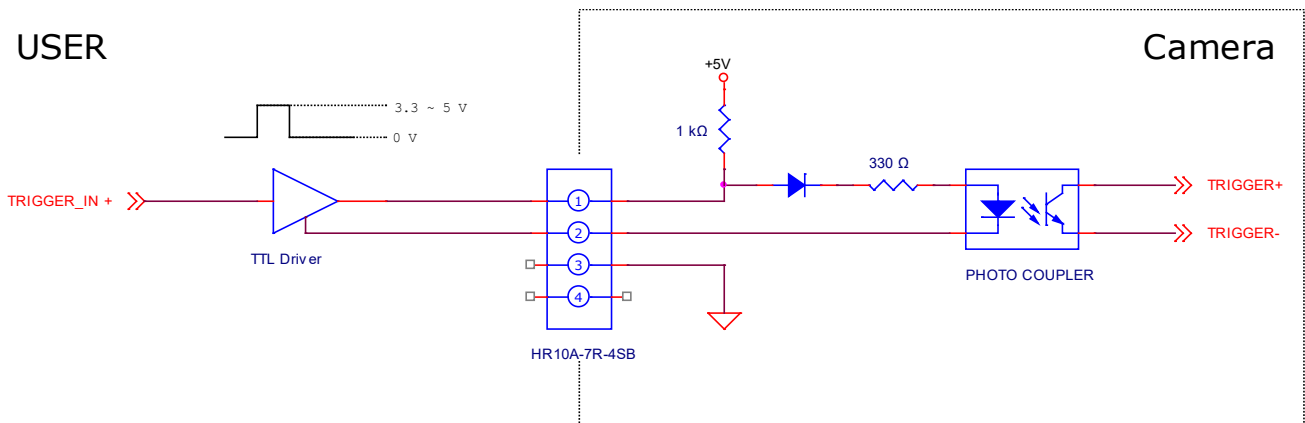

Figure 7.5 Trigger Input Schematic

7.6 Strobe Output Circuit

The strobe output signal comes out through a 3.3 V output level of Line Driver IC. The pulse width of signal is synchronized with the exposure signal (shutter) of the camera.

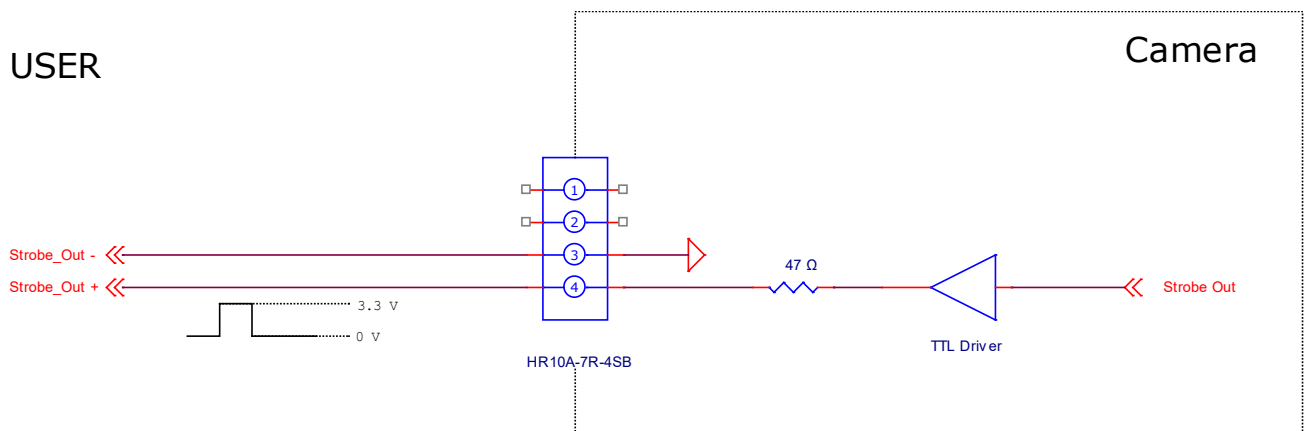

Figure 7.6 Strobe Output Schematic

8 Camera Features

8.1 Region of Interest

The Region of Interest (ROI) feature allows you to specify a portion of the sensor line(s). During operation, only the pixel information from the specified portion of the line(s) is read out of the sensor and transmitted from the camera to the frame grabber.

The ROI is referenced to the left end of the sensor array. The location and size of the ROI is defined by declaring the **Offset X** and **Width** settings. For example, suppose that you set the Offset X value to 16 and the Width value to 160 as shown in the following figure. With these settings, the camera will read out and transmit pixel values for pixels 17 through 176.

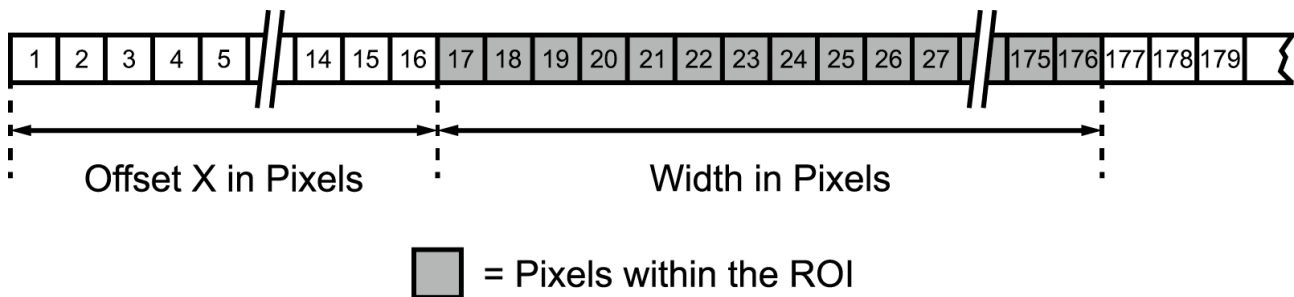

Figure 8.1 Region of Interest

8.1.1 Setting the ROI

By default, the ROI is set to use the full resolution of the camera's sensor. You can change the size and location of the ROI by changing the Offset X ('sio' command) and Width ('siw' command) settings.

When you are setting the camera's region of interest, you must consider the following guidelines:

- The sum of the Offset X and Width setting values must not exceed the width of the camera's sensor. For example, on the VL-8K7C-M80F-2 camera, the sum of the Offset X and Width settings values must not exceed 8192.
- The Offset X setting value can be set to 0 and can be increased in increments of 16. The Width setting values must be a minimum of 160 and can be set to a multiple of 16.



Your frame grabber may place additional restrictions on how the ROI location and size must be set. Refer to your frame grabber user manual for more information.

8.2 Image Mode (VL-8K7C-M80F-2 Only)

The VL-8K7C-M80F-2 camera allows you to acquire lines with several different methods. Each of these different methods is referred to as Image Mode. The VL-8K7C-M80F-2 provides the following image modes.

- Single Line (Low Sensitivity)
- Dual Line (High Sensitivity)
- Horizontal Binning
- Vertical Binning
- H & V Binning

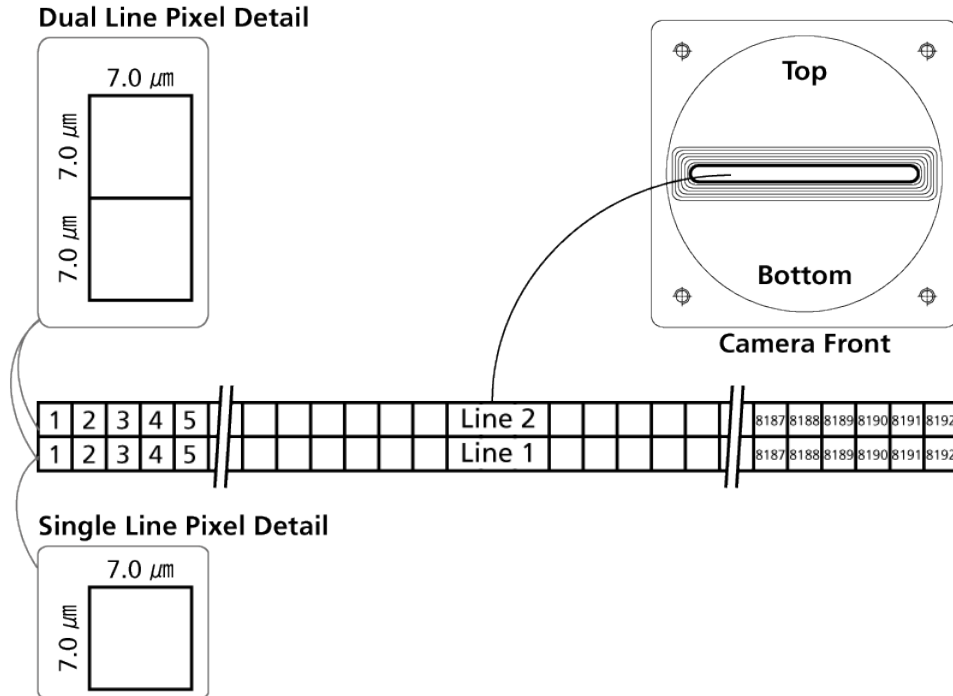

Figure 8.2 VL-8K7C-M80F-2 Dual Line Sensor Structure

8.2.1 Single Line

When you set **Image Mode** to **Single Line**, the camera will use Line 1. Each time a line acquisition is triggered, only Line 1 will be exposed. When exposure ends, the pixel values from the Line 1 will be read out of the sensor and transmitted from the camera.

The maximum line acquisition rate is 80 kHz at full resolution when the camera is set to Single Line.

8.2.2 Dual Line

When you set **Image Mode** to **Dual Line**, both Line 1 and Line 2 will be exposed each time a line acquisition is triggered. When exposure ends, the pixel values will be handled in one of the following ways:

When you set **Image Direction** to **Forward**,

- The pixel values from the Line 1 will be read out of the sensor and will be stored in a buffer in the camera.
- The pixel values from the Line 2 will be read out of the sensor and they will be summed with the pixel values for Line 1 that were stored during the previous acquisition cycle.
- The total value will be divided by 2.
- Then, the averaged values will be transmitted from the camera as though they were from a single line.

When you set **Image Direction** to **Backward**,

- The pixel values from the Line 2 will be read out of the sensor and will be stored in a buffer in the camera.
- The pixel values from the Line 1 will be read out of the sensor and they will be summed with the pixel values for Line 2 that were stored during the previous acquisition cycle.
- The total value will be divided by 2.
- Then, the averaged values will be transmitted from the cameras as though they were from a single line.

The Dual Line mode can be useful if you want to decrease the noise level in the pixel values output from the camera. Using the Dual Line mode will result in an increase of approximately 40% in the signal to noise (SNR) ratio.

8.2.2.1 Image Direction

When you acquire lines using the **Dual Line** mode in the VL-8K7C-M80F-2 camera, you need to set the **Image Direction** option.

You should set the Image Direction option to **Forward** if the object being acquired will pass Line 1 (the bottom of the camera) first, and then pass Line 2 (the top of the camera). On the contrary, you should set the Image Direction option to **Backward** if the object being acquired will pass Line 2 first, and then pass Line 1.

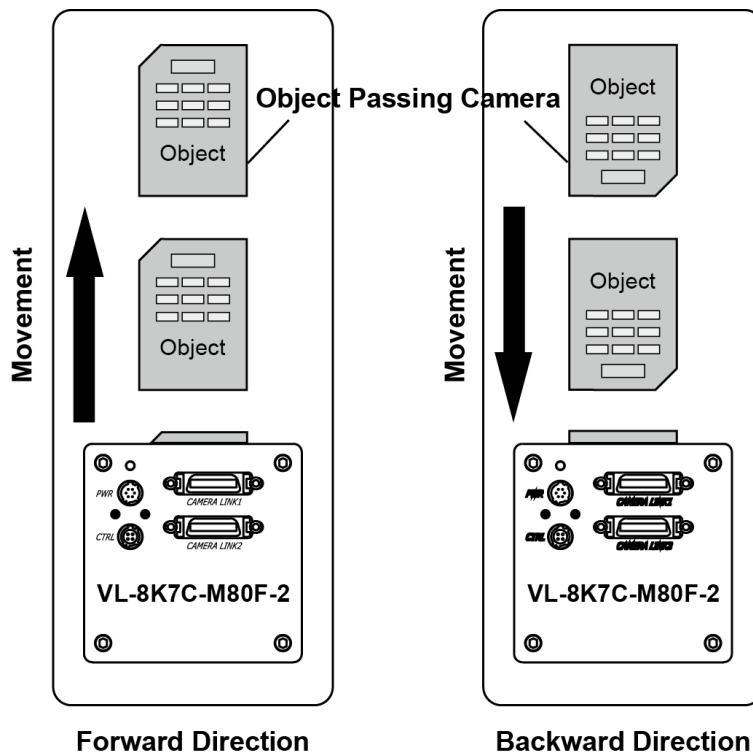

Figure 8.3 Image Direction

You can also set the Image Direction through the Camera Link CC3 (Control Port 3) port. To set the Image Direction option to Forward, CC3 must be low. To set the Image Direction to Backward, CC3 must be high.

8.2.3 Binning

8.2.3.1 Horizontal Binning

When you set the **Image Mode** to **Horizontal Binning**, only Line 1 will be exposed each time a line acquisition is triggered. When exposure ends, adjacent pixels are summed as shown in the figure below. Then, the total value will be averaged (divided by 2) and transmitted from the camera as though they were from a single pixel. Using the Horizontal Binning mode will result in an increase of approximately $\times 1.4$ in the signal to noise (SNR) ratio. With Horizontal Binning is enabled, the effective resolution of a sensor is halved: For the VL-8K7C-M80F-2 camera, the effective resolution becomes 4096.

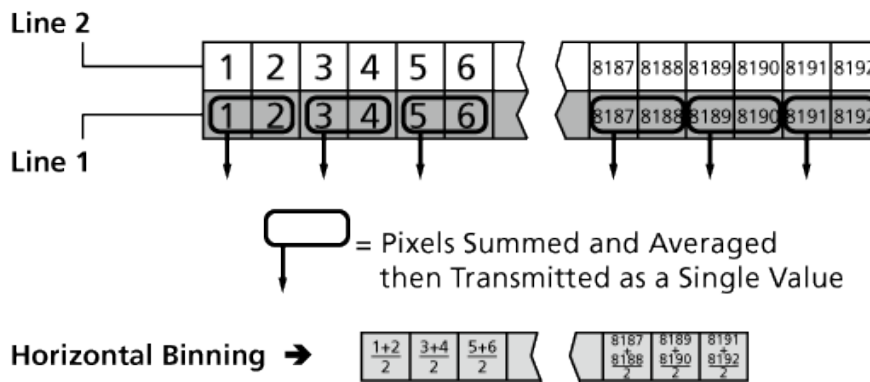

Figure 8.4 Horizontal Binning

8.2.3.2 Vertical Binning

When you set the **Image Mode** to **Vertical Binning**, both Line 1 and Line 2 will be exposed each time a line acquisition is triggered. When exposure ends, the pixel values from Line 1 will be added to the pixel values from Line 2 as shown in the figure below. Then, the total value will be averaged (divided by 2) and transmitted from the camera as though they were from a single pixel. Using the Vertical Binning mode will result in an increase of approximately $\times 1.4$ in the SNR ratio.

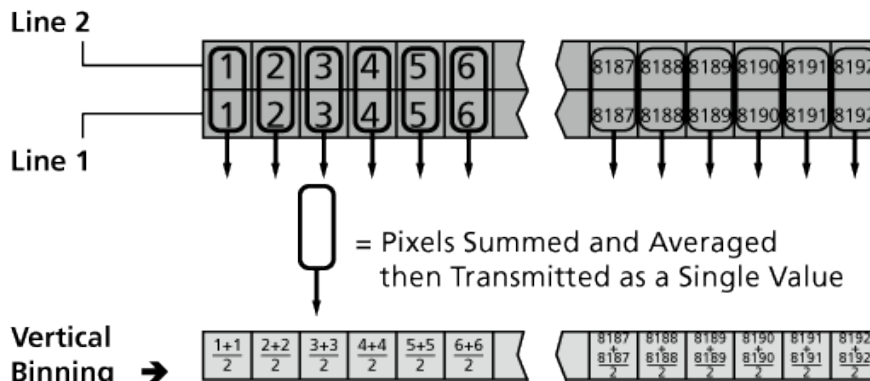

Figure 8.5 Vertical Binning

8.2.3.3 H & V Binning

When you set the **Image Mode** to **H & V Binning**, you can use the Horizontal Binning mode together with the Vertical Binning mode. Using the H & V Binning mode will result in approximately double the SNR.

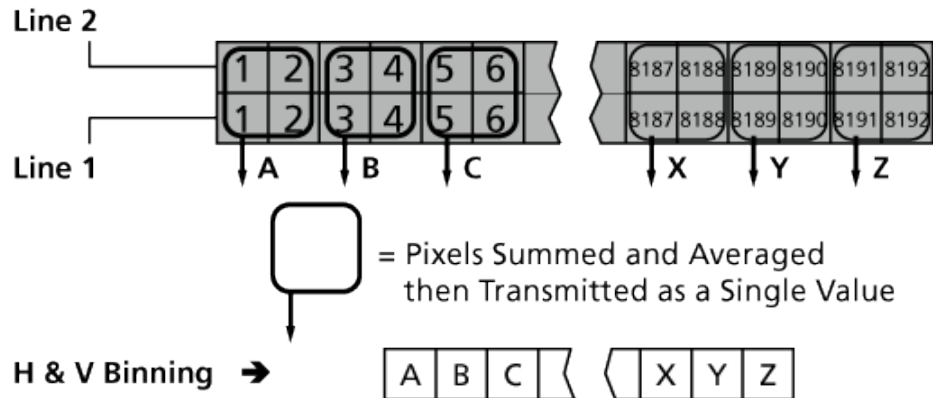

Figure 8.6 H & V Binning

8.2.3.4 Vertical Binning vs. Dual Line

In the Vertical Binning mode the vertically adjacent pixel values will be summed, averaged, and then transmitted in a fashion similar to the Dual Line mode. In the Vertical Binning mode, both Line 1 and Line 2 will be exposed simultaneously, and then adjacent pixels will be summed, averaged, and transmitted. In the Dual Line mode, however, one of the two lines will be exposed with a delay (one line transfer time), and then adjacent pixels will be summed, averaged, and transmitted. As a result of these differences, images acquired from one line will be overlapped with images acquired from the other line in the Vertical Binning mode so that modulation transfer function (MTF) of the images will be decreased in the vertical direction. However, you can acquire sharp images without decreasing MTF in the Dual Line mode because those images are synchronized with the object being imaged.

8.3 Trigger Mode

The trigger mode of the camera is divided into Trigger synchronous mode and Trigger asynchronous mode (hereinafter “Free-Run” mode) depending on its synchronization with trigger input. The trigger synchronous mode is divided into External Sync mode and External Sync Converter mode.

8.3.1 Free-Run

In the Free-Run mode, an external trigger signal is not required. The camera generates its own internal trigger signals based on the Line Period and Exposure Time settings. In the Free-Run mode, the camera exposes and transmits lines continuously and the Line Period settings will determine the camera’s line rate as follows:

$$\text{Line Rate (Hz)} = \frac{1}{\text{Line Period}}$$

In the Free-Run mode, line acquisition begins on the falling edge of the internal trigger signal as shown in the figure below. The pixels are exposed and charge is accumulated when the internal trigger signal is ‘High’. Then, the pixel values are read out of the sensor on the falling edge of the internal trigger signal. The Exposure Time (‘set’ command) setting determines how long the internal trigger signal will be high and thus determines the exposure time. The exposure time can be set in a range from 2 μs up to Line Period. The exposure time may be restricted by the Line Period setting. If this is the case, you must first increase the Line Period setting to increase the exposure time.

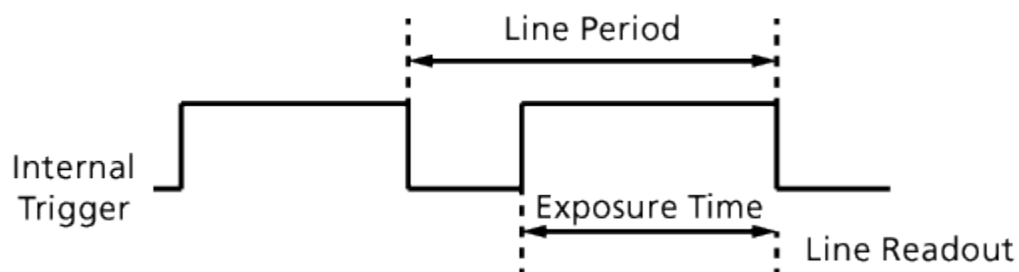

Figure 8.7 Free-Run Mode

8.3.2 External Sync

In the External Sync mode, the camera's line rate and exposure time are controlled by an external trigger signal. The external trigger signal is typically supplied to the camera by a frame grabber (CC1 Port) via the Camera Link cable or by injecting an externally generated electrical signal into the Control Receptacle (External). When you operate the camera in the External Sync mode, the length of the external trigger signal period determines the camera's line rate as follows:

$$\text{Line Rate (Hz)} = \frac{1}{\text{External Trigger Period}}$$

When the camera is operating with an external trigger signal, three Exposure modes are available: Program, Pulse Width and Edge.

You can also set the Source and Polarity for the external trigger signal.

- **Source:** selects an input port of the external trigger signal between **CC1** and **External**.
- **Polarity:** selects the polarity of the external trigger signal between **Active High** and **Active Low**.

The following instructions assume that you have set the **Polarity** setting to **Active High**.

8.3.2.1 External Sync Program

When the **Exposure** setting is set to **Program**, line acquisition begins on the rising edge of the external trigger signal. The exposure starts when the external trigger signal rises, and continues as long as specified by the **Exposure Time** setting. Then, the pixel values are read out of the sensor at the end of the pre-programmed period.

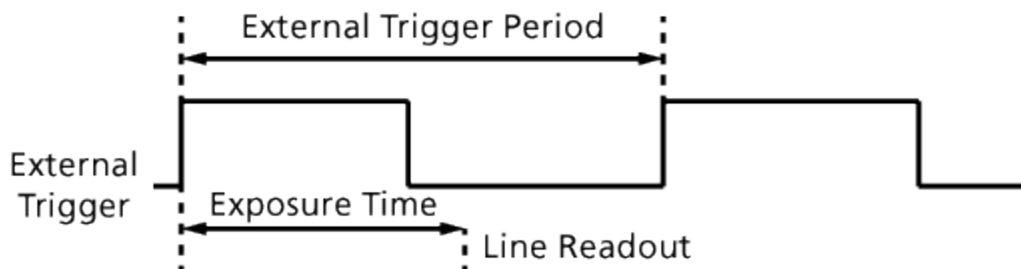

Figure 8.8 External Sync Program Mode

8.3.2.2 External Sync Pulse Width

When the **Exposure** setting is set to **Pulse Width**, line acquisition begins on the rising edge of the external trigger signal. The exposure time is determined by the time interval between the point where an external trigger signal rises and the point where the external trigger signal falls. The pixels are exposed only when the external trigger signal is High. Then, the pixel values are read out of the sensor on the falling edge of the external trigger signal as shown in the figure below.

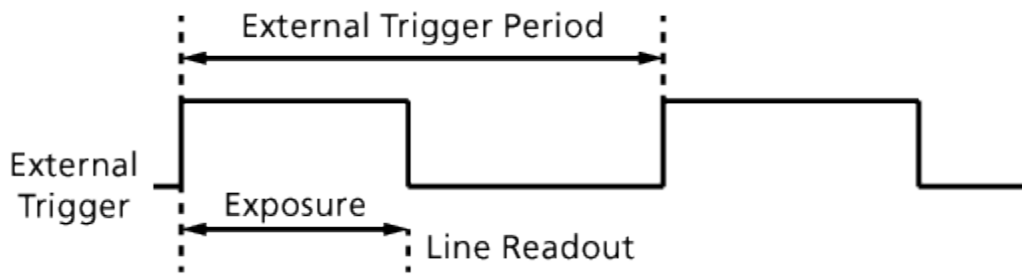

Figure 8.9 External Sync Pulse Width Mode

8.3.2.3 External Sync Edge

When the **Exposure** setting is set to **Edge**, line acquisition begins on the rising edge of the external trigger signal. The pixels are exposed and charge is accumulated over the full period of the external trigger signal (rising edge → rising edge). Then, the pixel values are read out of the sensor on the rising edge of the external trigger signal as shown in the figure below.

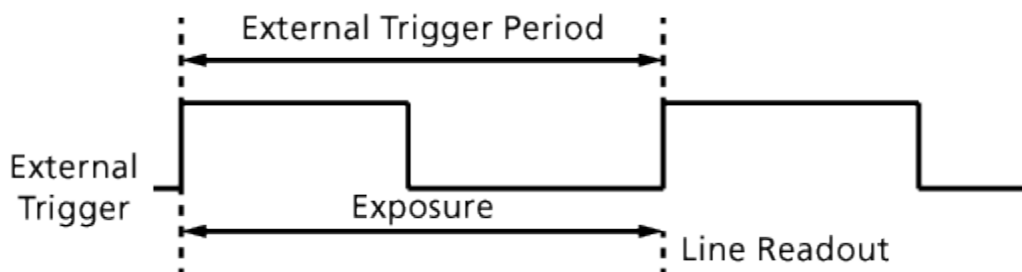

Figure 8.10 External Sync Edge Mode

8.3.3 External Sync Converter

Operation in the External Sync Converter mode is similar to the External Sync mode. In the External Sync Converter mode, however, you can modulate the period of the external trigger signal rate as desired.

For example, if you supply the external trigger signal into the camera's control receptacle using the conveyor's encoder, the number of output pulses per revolution of the encoder is fixed. In this situation, you can modulate the period of the trigger signal received from the camera in the following manner to match the pitch of the image in vertical direction.

$$\text{Line Rate (Hz)} = \text{External Trigger Line Rate} \times \text{Trigger Converter Ratio}$$

You can set the **Frequency Rate** (Trigger Converter Ratio) from 0.02 to 100.00 in increments of 0.01 by using Configurator or the 'stc' command.

In the External Sync Converter mode, two exposure modes are available: **Program** and **Edge**.

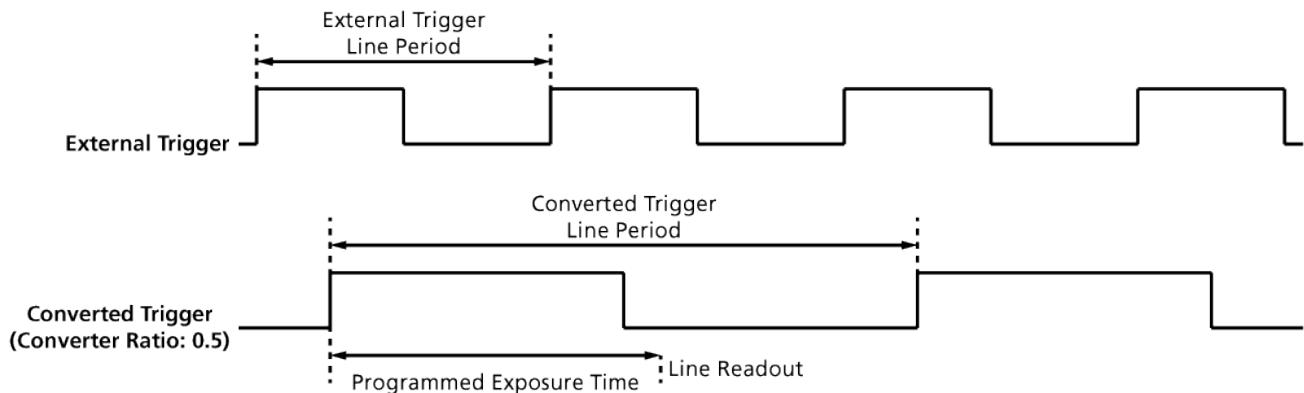

Figure 8.11 External Sync Converter

8.4 Camera Link Output

VL series supports 2 Tap, 4 Tap and 8 Tap Camera Link output modes. The number of taps represents the number of pixel data that will be output on each cycle of the Camera Link Pixel Clock. The maximum allowed line rate will be changed according to the Camera Link output modes. The line data is transmitted in the interleaved order as shown in the figure below. You can set the Camera Link output mode by using the 'scl' command.

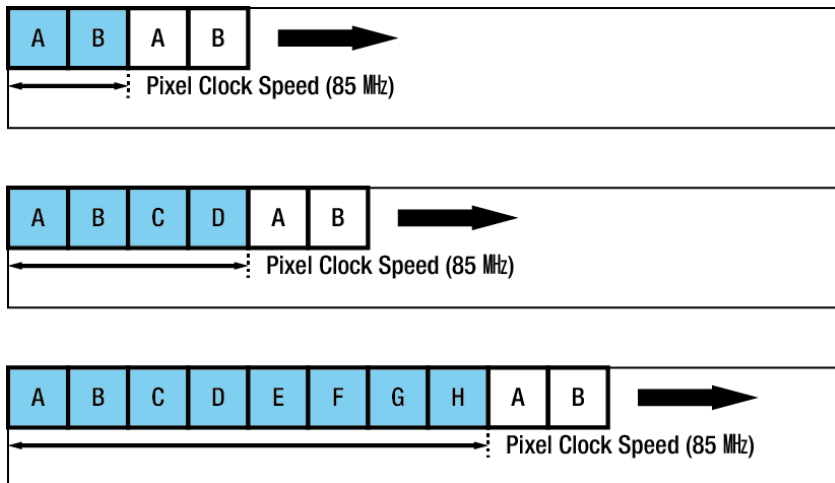

Figure 8.12 Camera Link Output Mode

8.5 Data Bit

The camera processes image data in the unit of 12 bit. You can determine the pixel format (8 bits, 10 bits or 12 bits) of these image data transmitted from the camera by using the Data Bit parameter. When the camera is set for 8-bit or 10-bit pixel format, the four or two least significant bits will be dropped from the overall 12 bits. You can set the 8-bit, 10-bit or 12-bit pixel format with 2 Tap and 4 Tap Camera Link output modes, but the 8-bit pixel format is only available with the 8 Tap Camera Link output mode.

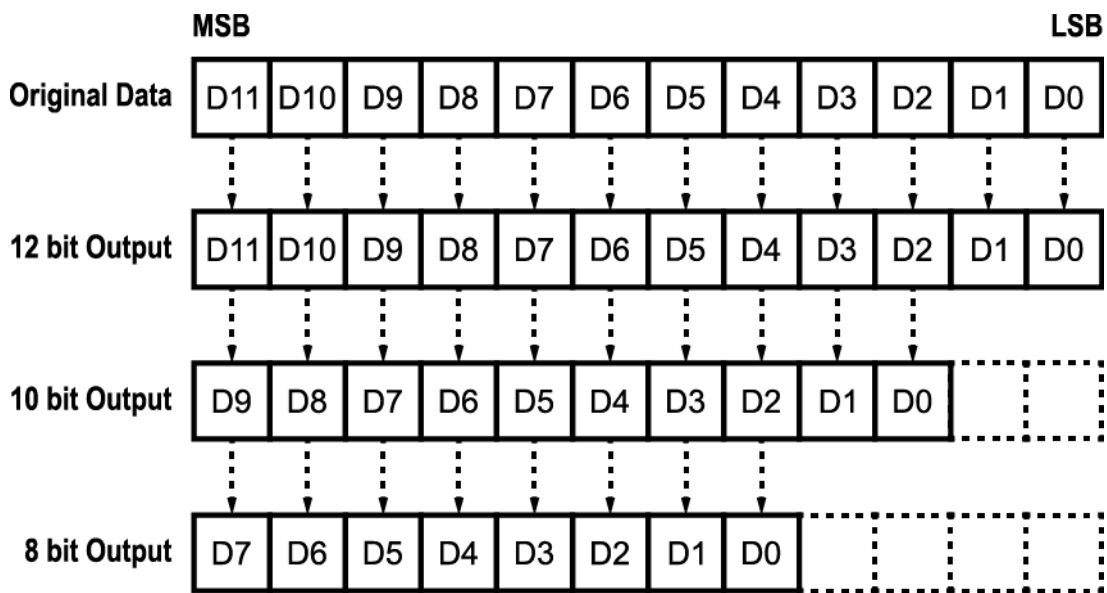

Figure 8.13 Data Format

8.6 Gain and Offset

VL series allows you to adjust Gain and Offset settings. You can set the Gain setting with Configurator or by using the 'sdg' command in a range from $\times 1.00$ to $\times 32.00$. You can set the Offset setting by using Configurator or the 'sdo' command in a range from 0 to 2048 for 12 bit of the Data Bit setting. For more information, refer to [9. Camera Configuration](#).

8.7 Test Image

To check whether the camera operates normally or not, it can be set to output test images generated in the camera instead of the image data from the imaging sensor. Three types of test images are available, image with different value in horizontal direction (Test Image 1), image with different value in diagonal direction (Test Image 2), and moving image with different value in diagonal direction (Test Image 3).

You can set the Test Image mode by using Configurator or the 'sti' command in all camera operation modes.

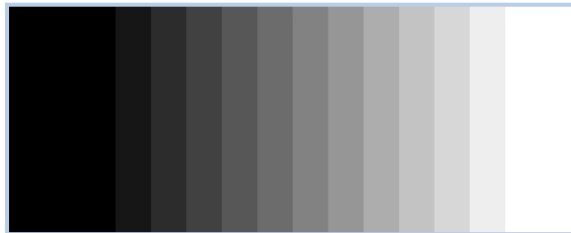

Figure 8.14 Test Image 1

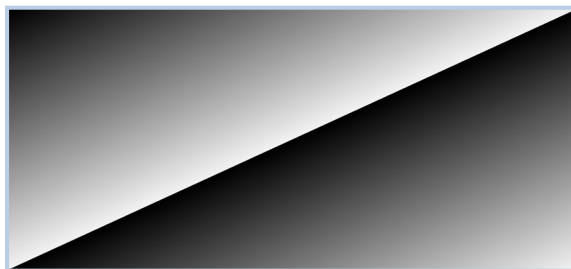

Figure 8.15 Test Image 2



Figure 8.16 Test Image 3

8.8 Dark Signal Non-uniformity Correction

In theory, when a line scan camera acquires images in complete darkness, all of the pixel values in the image should be near zero and they should be equal. In practice, however, slight variations in the performance of the pixels in the sensor will cause some variations in the pixel values output from the camera when the camera is acquiring in darkness. This variation is known as Dark Signal Non-uniformity (DSNU). VL series provides the DSNU Correction feature and contains DSNU correction values in the Flash memory. These values are generated during the camera's factory setup procedure and they serve as default correction values until you change them.

8.8.1 Generating and Saving User DSNU Correction Values

To generate and save user DSNU correction values, use the following procedure.



For optimum DSNU correction results, we recommend to generate DSNU data after the temperature of the camera housing has been stabilized.

1. The camera will use the entire sensor when generating DSNU correction values. Therefore, we recommend that you set the ROI setting to use the entire width of the sensor.
2. Ensure that the camera will be acquiring line images in complete darkness by covering the camera lens, closing the iris in the lens, or darkening the room.
3. Begin acquiring line images either by setting the camera for the Free-Run mode or by supplying external trigger signals to trigger line acquisitions.

4. In Configurator, click the **Generate** ('gdd' command) button to generate DSNU correction values.
5. The camera must acquire at least 1024 line images to create a set of DSNU correction values.
6. After completing 1024 line acquisitions, the generated DSNU correction values will be activated and saved in the camera's volatile memory.
7. To save the generated DSNU correction values in the camera's Flash (non-volatile) memory, click the **Save to Flash** ('ssd' command) button. Existing values in the memory will be overwritten.

To ignore the generated DSNU correction values and load existing values in the Flash memory, click the **Load from Flash** ('ldd' command) button.

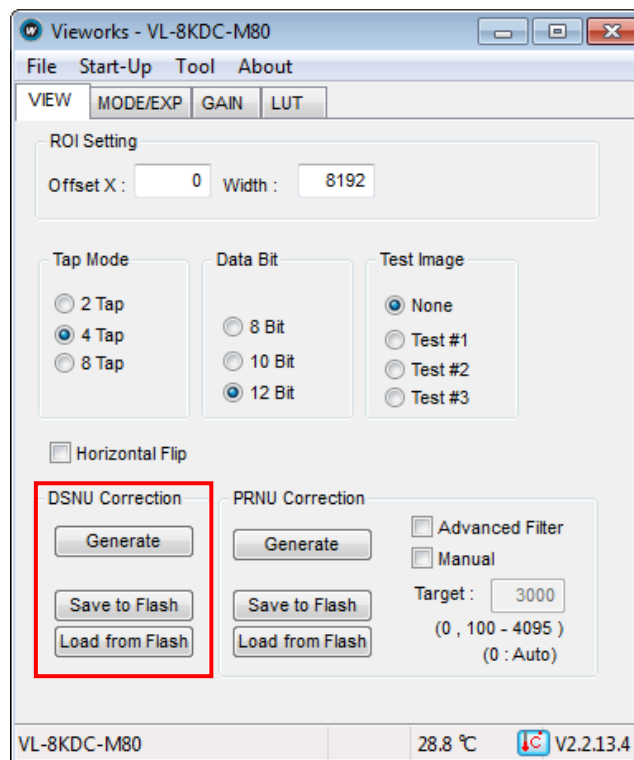

Figure 8.17 DSNU Correction

8.9 Photo Response Non-uniformity Correction

In theory, when a line scan camera acquires images with the camera viewing a uniform light-colored target in bright light, all of the pixel values in the image should be near the maximum gray value and they should be equal. In practice, however, slight variations in the performance of the pixels in the sensor, variations in the optics, and variations in the lighting will cause some variations in the pixel values output from the camera. This variation is known as Photo Response Non-uniformity (PRNU). VL series provides the PRNU Correction feature and contains PRNU correction values in the Flash memory. These values are generated during the camera's factory setup procedure and they serve as default correction values until you change them.

8.9.1 Generating and Saving User PRNU Correction Values

To generate and save user PRNU correction values, use the following procedure.



- We strongly recommend that you generate new PRNU correction values whenever you make a change to the optics or lighting or if you change the camera's exposure mode or exposure time.
- For optimum PRNU correction results, we recommend to generate DSNU correction values first before generating PRNU correction values.

1. The camera will use the entire sensor when generating PRNU correction values. Therefore, we recommend that you set the ROI setting to use the entire width of the sensor.
2. Place a uniform white target in the field of view of the camera. Adjust the optics, lighting, exposure mode and exposure time as you would for normal operation. We recommend that you make adjustments to achieve the digital output level in a range from 200 to 3000 (Data Bit: 12 bit, Gain: 1.00).
3. Begin acquiring line images either by setting the camera for the Free-Run mode or by supplying external trigger signals to trigger line acquisition.

4. In Configurator, set the target level and determine whether to use the Advanced Filter.
 - If the acquired images are not uniform due to a scratch or dust, select the **Advanced Filter** check box to generate correction values with eliminating high frequency portion caused by the scratch or dust.
 - To set the target level automatically, select the **Target Level** check box and then input '0', or deselect the **Target Level** check box.
 - To set the target level manually, select the **Target Level** check box and input the target level ('gpd <target level/ value>' command) in a range from 100 to 4095.
 - From version 1.1.12 of the firmware, the PRNU target range is adjusted automatically if setting the Target Level manually as the followings:
 - 8bit : up to 255
 - 10bit : up to 1023
 - 12bit : up to 4095
5. In Configurator, click the **Generate** ('gpd' command) button to generate PRNU correction values.
6. The camera must acquire at least 1024 line images to create a set of PRNU correction values.

7. After completing 1024 line acquisitions, the generated PRNU correction values will be activated and saved in the camera's volatile memory.
8. To save the generated PRNU correction values in the camera's Flash (non-volatile) memory, click the **Save to Flash** ('spd' command) button. Existing values in the memory will be overwritten.

To ignore the generated PRNU correction values and load existing values in the Flash memory, click the **Load from Flash** ('lpd' command) button.

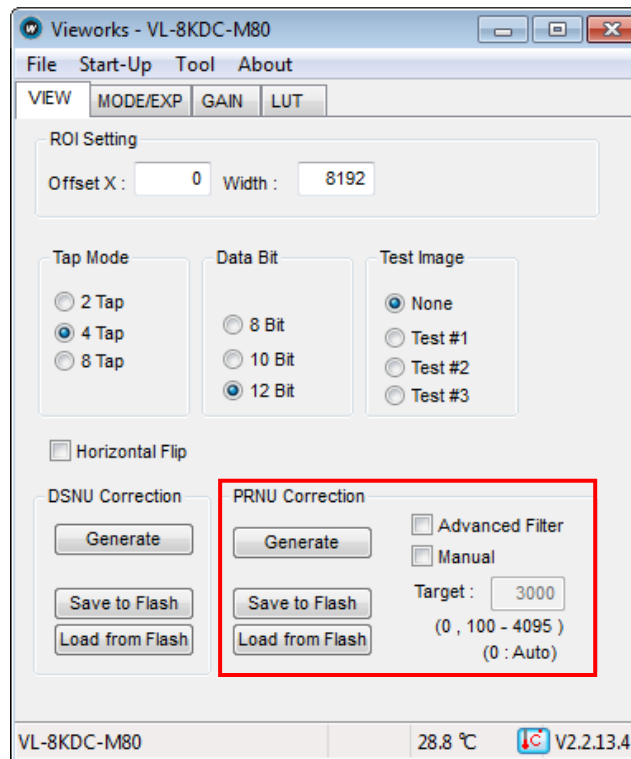

Figure 8.18 PRNU Correction

8.10 Temperature Monitor

The camera has an embedded sensor chip to monitor the internal temperature. You can check the temperature of the camera by using Configurator or the 'gct' command.

8.11 Status LED

A green LED is installed on the back panel of the camera to inform the operation status of the camera. LED status and corresponding camera status are as follows:

Status LED	Descriptions
Continuous On	The camera operates in the Free-Run mode.
Repeat On for 0.5 second, Off for 0.5 second	The camera operates under the control of external sync signals.
Repeat On for 1 second, Off for 1 second	The camera outputs test images.
Repeat On for 0.25 second, Off for 0.25 second	The camera operates under the control of external sync signals and outputs test images.

Table 8.1 Status LED Descriptions

8.12 Horizontal Flip

The Horizontal Flip feature let you flip the image horizontally. This feature is available in all camera operation modes except the Test Image mode. You can determine whether to use the Horizontal Flip feature by using Configurator or the 'shf' command.



Figure 8.19 Original Image



Figure 8.20 Horizontally Flipped Image

8.13 Strobe Out

The camera can provide a Strobe Out signal. The signal goes high when the exposure time for each line acquisition begins and goes low when the exposure time ends as shown in the figure below. This signal can be used as a flash trigger and is also useful to check whether the camera is in an exposure status.

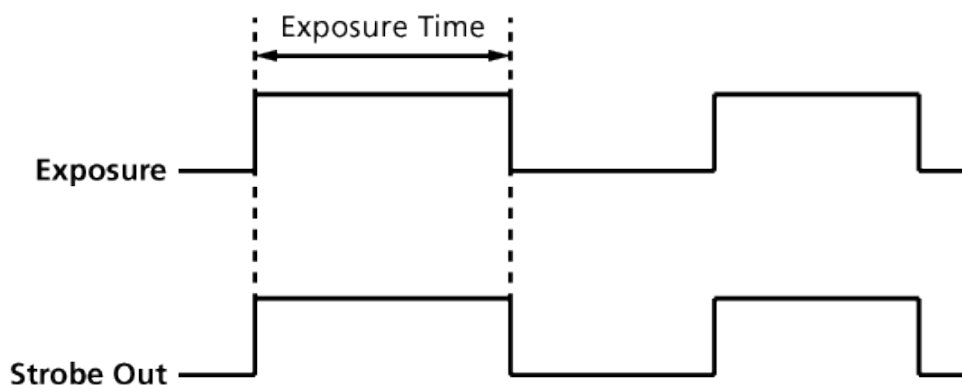

Figure 8.21 Strobe Out Signal

8.14 Field Upgrade

The camera provides a feature to upgrade the firmware and FPGA logic through RS-644 of the Camera Link interface rather than disassemble the camera in the field. For more information about how to upgrade, refer to [Appendix B](#).

9 Camera Configuration

9.1 Setup Command

You can configure all required settings of the camera through RS-644 serial communication of the Camera Link interface. When you want to control the camera by using a terminal or access to the camera within your application, you need to set your network as follows:

- Baud Rate: 115200 bps
- Data Bit: 8 bit
- Parity Bit: No Parity
- Stop Bit: 1 stop bit
- Flow Control: None

All types of the camera setting commands are delivered in ASCII command type except Firmware Download requiring massive data transmission. All camera setting commands start from user application and then the camera returns a response ("OK", "Error" or information) for a command. The camera informs the completion of the command execution through a response for a write command while the camera returns an error response or information for a read command.

```
Command format:
<command> <parameter1> <parameter2> <cr>
0 -2 parameters follow the command.
Response:
- If execution of write command is successfully completed
OK <cr> <lf>
```

ex) Write command

```
In response to a "set 100" command the camera will return (in hex value)
Command   : 73 65 74 20 31 30 30 0D
           set 100<cr>
Response  : 73 65 74 20 31 30 30 0D 0A 4F 4B 0D 0A 3E
           set 100<cr><lf>           OK<cr><lf>  >
Echo      : result                  prompt
```

```
If execution of read command is successfully completed  
<parameter1> <cr> <lf>
```

ex) Read command

```
In response to a "get" command the camera will return (in hex value)  
Command      : 67 65 74 0D  
              get <cr>  
Response     : 67 65 74 0D 0A 31 30 30 0D 0A 3E  
              get<cr><lf>    100<cr><lf>    >  
              Echo          response      prompt
```

```
If execution of command is not completed  
Error : <Error Code> <cr> <lf>
```

```
Prompt:  
After sending response, camera sends prompt always. '>' is used as prompt.
```

Types of Error Code

```
0x80000481 : values of parameter not valid  
0x80000482 : number of parameter is not matched  
0x80000484 : command that does not exist  
0x80000486 : no execution right
```

9.2 User Set Control

The VL series provides three non-volatile spaces (Flash) for storing parameter settings and one work space (RAM) for operating the camera. Non-volatile spaces are divided into a Factory space (Factory Setting) that contains default setting values entered during the manufacturing, and two User spaces (User 1 Setting and User 2 Setting) that are available for saving user-defined setting values.

You can save the current camera settings to a user space or you can load the settings stored in one of the non-volatile spaces into the camera's work space. The default setting values stored in the factory space can be loaded into the camera's work space, but cannot be changed.

The setting values in the camera's volatile memory will be lost if the camera is reset or powered off.

To use the current setting values in the work space after a reset, you must save the settings to one of the user spaces.

By default, the Factory Setting will be loaded into the camera when the camera is reset or powered on. You can change the Configuration Initialization value to select which setting values will be loaded when the camera is reset or powered on.

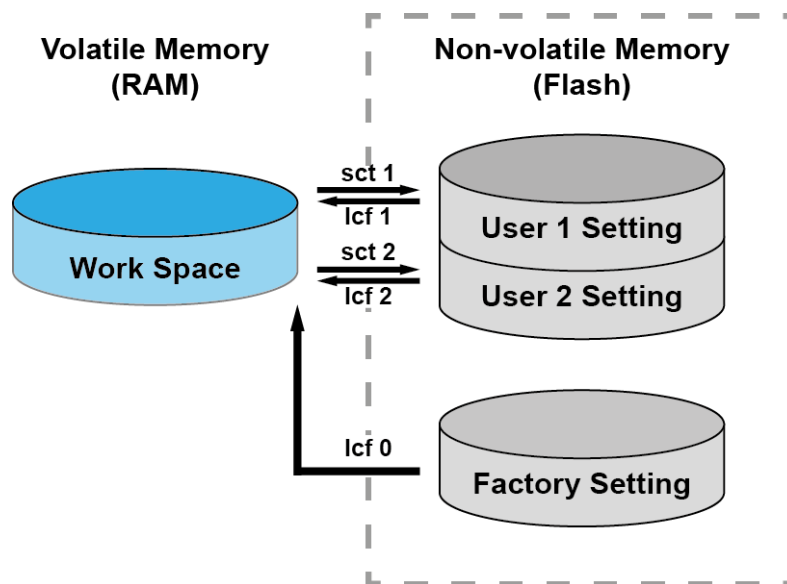

Figure 9.1 User Set Control

9.3 Command List

Command	Syntax	Return Value	Description
Help	h	String	Displays a list of all commands
Set Image Offset	sio n	OK	n: Starting point of ROI
Get Image Offset	gio	n	
Set Image Width	siw n	OK	n: Image width of ROI
Get Image Width	giw	n	
Set Line Period	slr f	OK	f: Line period (μs) <Float> (Setting range: Refer to Line Period in the Specifications.)
Get Line Period	glr	f	
Set Exposure Time	set f	OK	f: Exposure time (μs) <Float> (Setting range: 2.00 ~ 10,000.00 μs)
Get Exposure Time	get	f	
Set Test Image	sti 0 1 2 3	OK	0: Off 1/2: Fixed pattern image 3: Moving pattern image
Get Test Image	gti	0 1 2 3	
Set Data Bit	sdb 8 10 12	OK	8: 8 bit output 10: 10 bit output 12: 12 bit output
Get Data Bit	gdb	8 10 12	
Set Camera-Link Mode	scl 0 1 2	OK	0: 2 Tap Base 1: 4 Tap Medium 2: 8 Tap Full
Get Camera-Link Mode	gcl	0 1 2	
Set Camera Link Clock Speed	sccs 0 1 2 3	OK	0: 50 MHz 1: 60 MHz 2: 70 MHz 3: 85 MHz
Get Camera Link Clock Speed	gccs	0 1 2 3	
Set Horizontal Flip	shf 0 1	OK	0: Off 1: Enable the horizontal flip
Get Horizontal Flip	ghf	0 1	

Table 9.1 Command List #1

Command	Syntax	Return Value	Description
Set Digital Gain	sdg f	OK	f: Digital gain parameter <Float>
Get Digital Gain	gdg	f	(Setting range: 0.0 ~ 32.0)
Set Digital Offset	sdo n	OK	n: Digital offset parameter
Get Digital Offset	gdo	n	(Setting range: 0 ~ 2048)
Set Trigger Mode	stm 0 1 2	OK	0: Free-Run mode
Get Trigger Mode	gtm	0 1 2	1: External Sync mode 2: External Sync converter mode
Set Exposure Source	ses 0 1 2	OK	0: Program exposure (by camera)
Get Exposure Source	ges	0 1 2	1: Pulse width (by external trigger signal) 2: Edge (by external trigger signal)
Set Trigger Source	sts 1 2	OK	1: CC1 port input (Camera Link)
Get Trigger Source	gts	1 2	2: External input (Control Receptacle)
Set Trigger Polarity	stp 0 1	OK	0: Active Low
Get Trigger Polarity	gtp	0 1	1: Active High
Set Trigger Converter	stc f	OK	f: Trigger converter ratio <Float>
Get Trigger Converter	gtc	f	(Setting rate: 0.10 ~ 100.00)
Set Image Mode	sim 0 1 2 3 4	OK	0: Single line (Low Sensitivity)
Get Image Mode	gim	0 1 2 3 4	1: Dual line (High Sensitivity) 2: Horizontal binning 3: Vertical binning 4: 2 × 2 binning
Generate DSNU Data	gdd	OK	Operate DSNU data generator
Save DSNU Data	sdd	OK	Save DSNU data
Load DSNU Data	ldd	OK	Load DSNU data
Generate PRNU Data	gpd n	OK	Operate PRNU data generator
Save PRNU Data	spd	OK	n: Target level (Setting range: 0<Auto>, 100 ~ 4095)
Load PRNU Data	lpd	OK	Save PRNU data Load PRNU data

Table 9.2 Command List #2

Command	Syntax	Return Value	Description
Load Config From	lcf 0 1 2	OK	0: Load from factory setting 1: Load from user 1 setting 2: Load from user 2 setting
Save Config To	sct 1 2	OK	1: Save to user 1 setting 2: Save to user 2 setting
Set Config Initialization Get Config Initialization	sci 0 1 2 gci	OK 0 1 2	0: Load from factory setting when initializing 1: Load from user 1 setting when initializing 2: Load from user 2 setting when initializing
Get MCU Version	gmv	String	Displays MCU version
Get Model Number	gmn	String	Displays model number
Get FPGA Version	gfv	String	Displays FPGA version
Get Serial Number	gsn piece	String	Displays serial number
Get Current Temperature	gct	String	Displays temperature value
Reset	rst	-	Reset camera

Table 9.3 Command List #3

10 Configurator GUI

Configurator, a sample application, is provided to control VL series camera. Configurator provides easy-to-use Graphic User Interface (GUI) for the user while using the commands mentioned in the previous chapters.

10.1 Camera Scan

When you execute the program while the camera is turned on, the Camera Scan window appears as shown in the figure below. At this time, the program checks serial port of your computer and DLL provided by the camera link to scan whether the camera is connected. If there is a camera connected, it displays model name on the screen. If the camera is not properly displayed on the screen, check the connection of cables and power of the camera, and click the **refresh** button. When you double-click a model name displayed on the screen, Configurator is executed and displays current setting values of the camera connected.

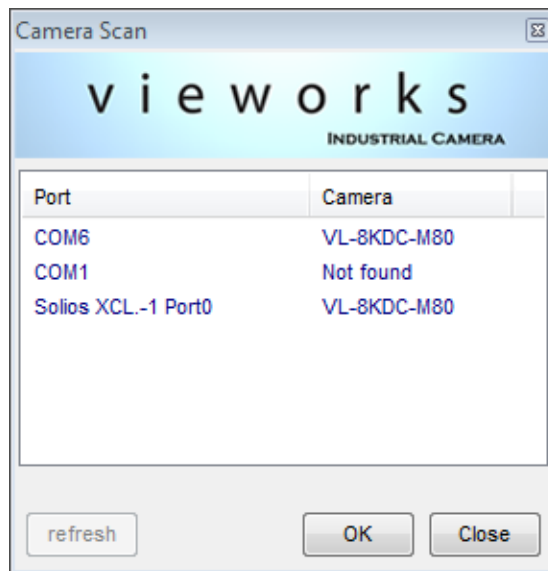

Figure 10.1 Configurator Loading Window

10.2 Menu

10.2.1 File

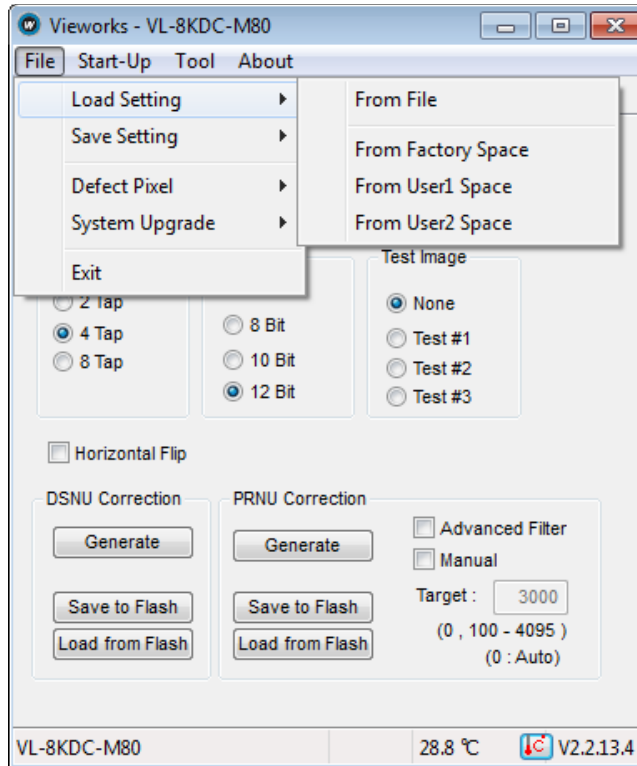

Figure 10.2 File menu

- **Load Setting:** Loads the camera setting values from the camera memory (Factory, User1 or User2) or user computer (From File).
- **Save Setting:** Saves the camera setting values to the camera memory (User1 or User2) or user computer (To File).
- **Defect Pixel:** Not supported on the VL series.
- **System Upgrade:** Upgrades MCU or FPGA logic.
For more information, refer to [Appendix B](#).
- **Exit:** Exits Configurator.

10.3 Start-Up

You can select the camera setting values to load when the camera is powered on.

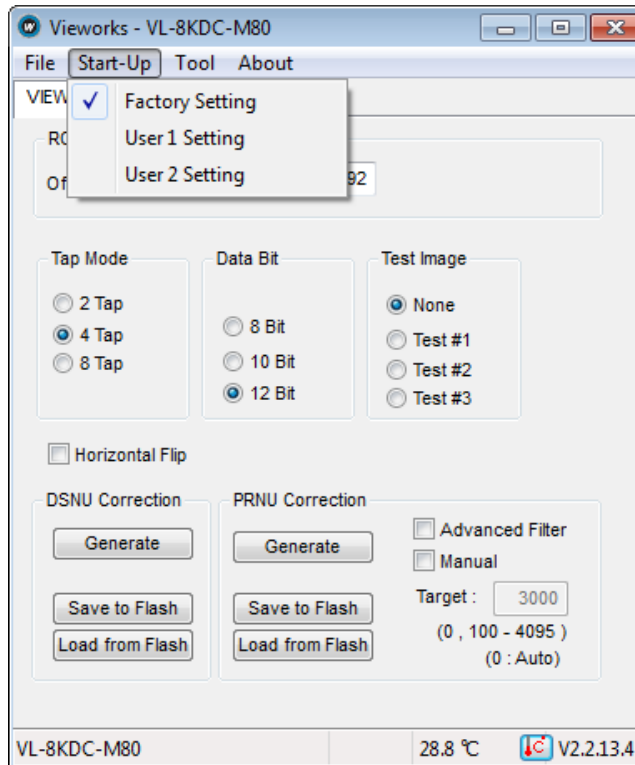

Figure 10.3 Start-Up menu

- **Factory Setting:** Loads the camera setting values from Factory Space when the camera is powered on.
- **User 1 Setting:** Loads the camera setting values from User 1 Space when the camera is powered on.
- **User 2 Setting:** Loads the camera setting values from User 2 Space when the camera is powered on.

10.3.1 Tool

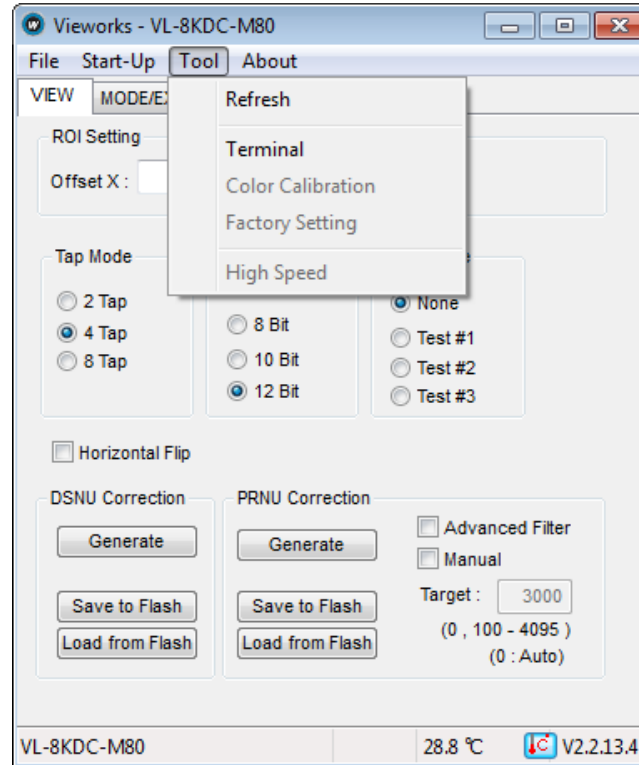

Figure 10.4 Tool menu

- **Refresh:** Loads and displays the current camera setting values on Configurator.
- **Terminal:** Allows you to input commands or displays GUI commands in the Terminal window. To hide the Terminal window, deselect Terminal by clicking again.
- **Color calibration:** Not supported on the VL series.
- **Factory Setting:** Not supported in user side.
- **High Speed:** Not supported on the VL series.

10.3.2 About

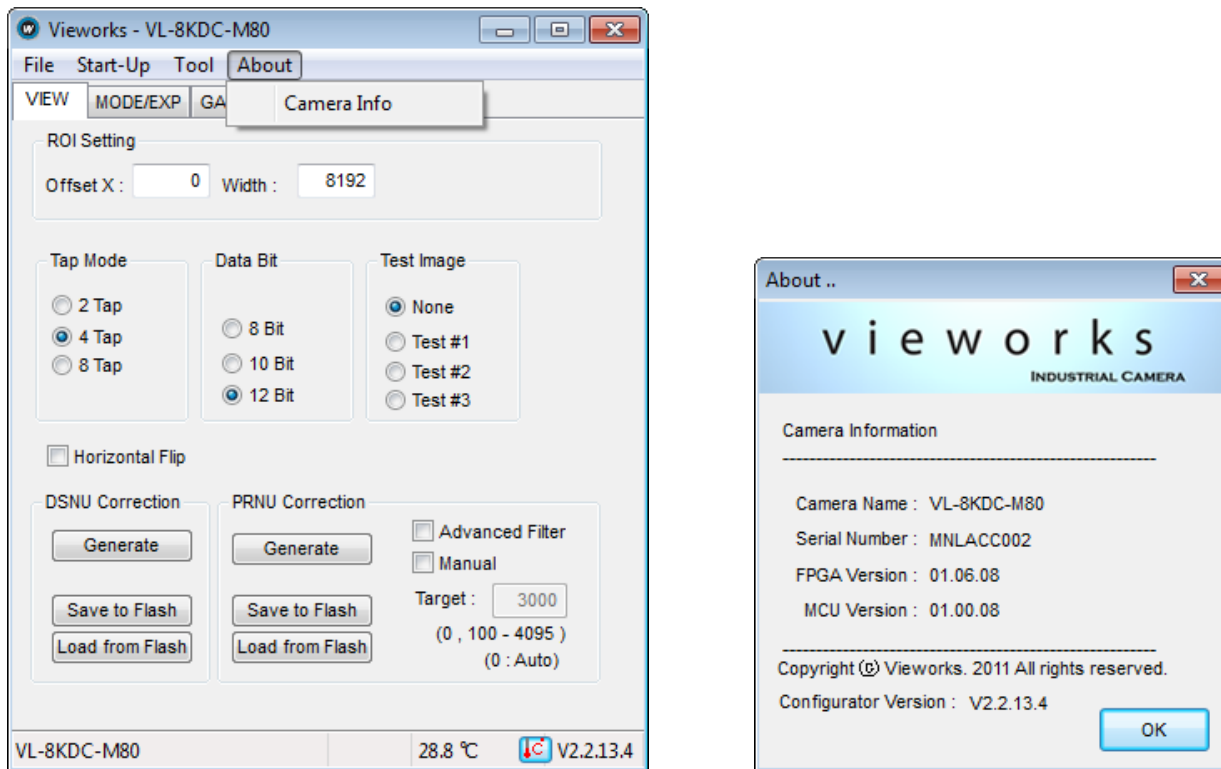

Figure 10.5 About menu

- **Camera Info:** Displays camera information (model name, serial number, version, etc).

10.4 Tab

10.4.1 VIEW Tab

VIEW tab allows you to set the camera's region of interest (ROI), test image mode, data bit, tap mode, correction features, etc.

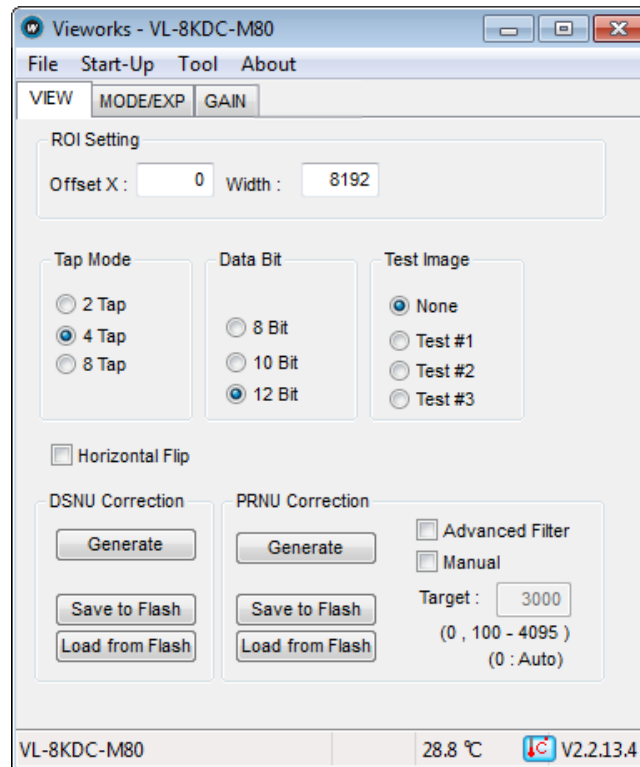

Figure 10.6 VIEW Tab

- **ROI Setting:** Sets the Offset X and Width values for the region of interest.
- **Tap Mode:** Select a Camera Link output mode.
- **Data Bit:** Select a data bit depth.
- **Test Image:** Enable/Disables the test image mode and selects the type of test images.
- **Horizontal Flip:** Sets the Horizontal Flip feature On or Off.
- **DSNU/PRNU Correction:** Generates, saves or loads the DSNU/PRNU correction data.

10.4.2 MODE/EXP Tab

MODE/EXP tab allows you to select trigger mode, exposure time and image mode.

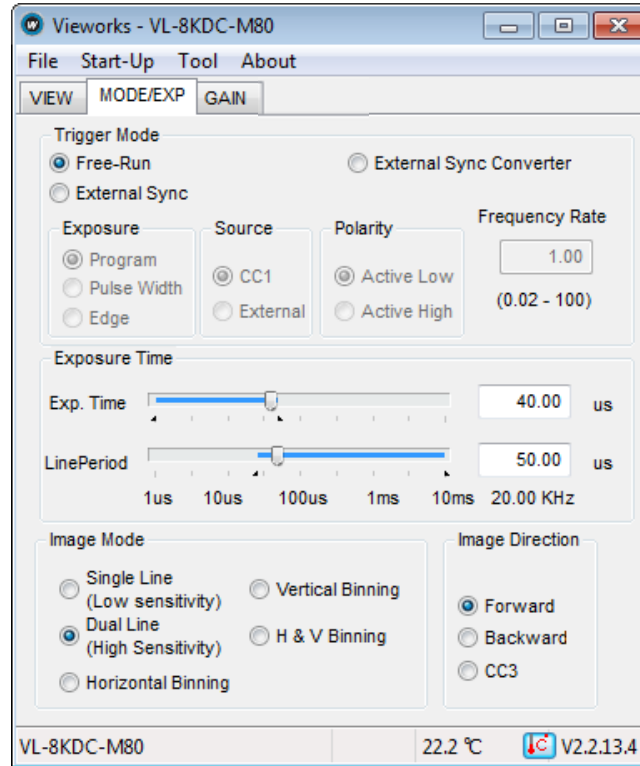

Figure 10.7 MODE/EXP Tab

- **Trigger Mode:** Selects a trigger mode. Once a mode has been selected, related selections will be activated.
- **Exposure:** Selects an exposure mode.
- **Source:** Selects a trigger source.
- **Polarity:** Selects a polarity of trigger input.
- **Exposure Time/Line Period:** Sets exposure time and line period when **Exposure** is set to **Program** or **Trigger Mode** is set to **Free-Run**.
- **Image Mode:** Selects an image mode (VL-8K7C-M80F-2 Only).
- **Image Direction:** Selects an image direction for the object being acquired in the Dual Line mode (VL-8K7C-M80F-2 Only).

10.4.3 GAIN Tab

GAIN tab allows you to set the gain and offset settings of the image. All scroll bars are controllable with the mouse wheel scroll.

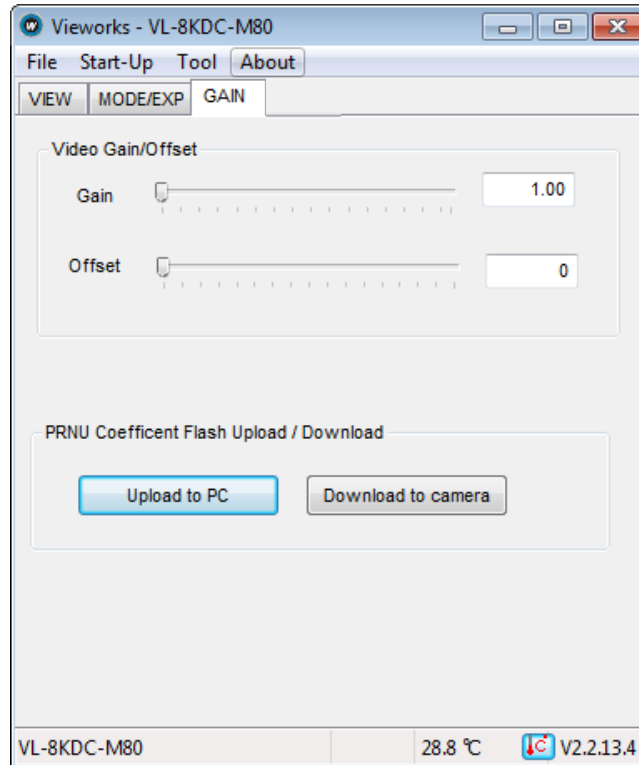

Figure 10.8 GAIN Tab

- **Gain:** Sets gain value of the camera.
- **Offset:** Sets offset value of the camera.
- **PRNU Coefficient Flash Upload/Download:** Uploads PRNU data stored in the camera's Flash memory to your computer or downloads PRNU data stored in your computer to the camera.

11 Troubleshooting

When you have a problem with a Vieworks camera, please check the followings:

- If no image is displayed on your computer,
 - Ensure that all cable connections are secure.
 - Ensure that the power supply is properly connected.
 - Ensure that trigger signals are applied correctly when you operate the camera with trigger signals.
- If images are not clear,
 - Ensure the camera lens or glass is clean.
 - Check the lens aperture is adjusted properly.
- If images are dark,
 - Ensure the camera lens is not blocked.
 - Check the exposure time is set properly.
- If you identify abnormal operation or overheating sign,
 - Ensure the power supply is properly connected.
 - Stop using the camera when you notice smoke or abnormal overheating.
- If the Trigger Mode is not working correctly,
 - Ensure that the CC1 settings on the frame grabber are configured correctly when you use CC1 triggering.
 - Ensure that cable connections are secure when you use external triggering.
- If there is a communication failure between the camera and user's computer,
 - Ensure that the Camera Link cable connections are secure.
 - Ensure that you have configured a frame grabber in your computer and the camera is connected to the frame grabber correctly.

Appendix A Field Upgrade

A.1 MCU

1. Select **File > System Upgrade -> MCU Upgrade** on Configurator.

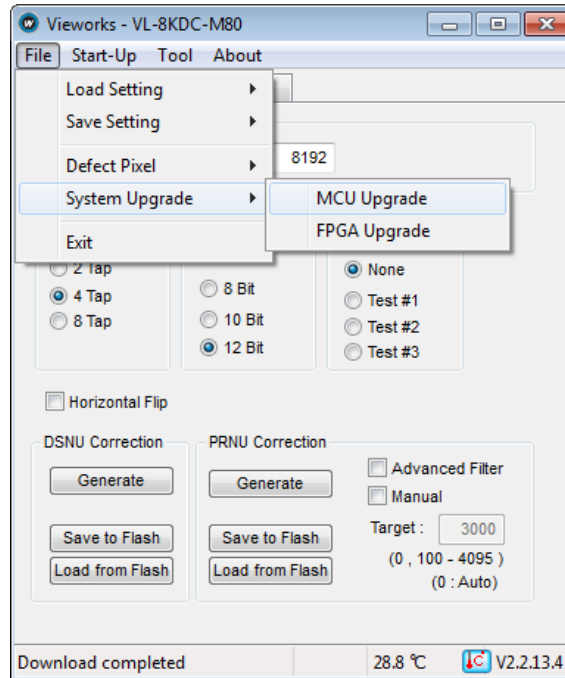

2. Locate the MCU upgrade file (*.srec) and click the **Open** button.

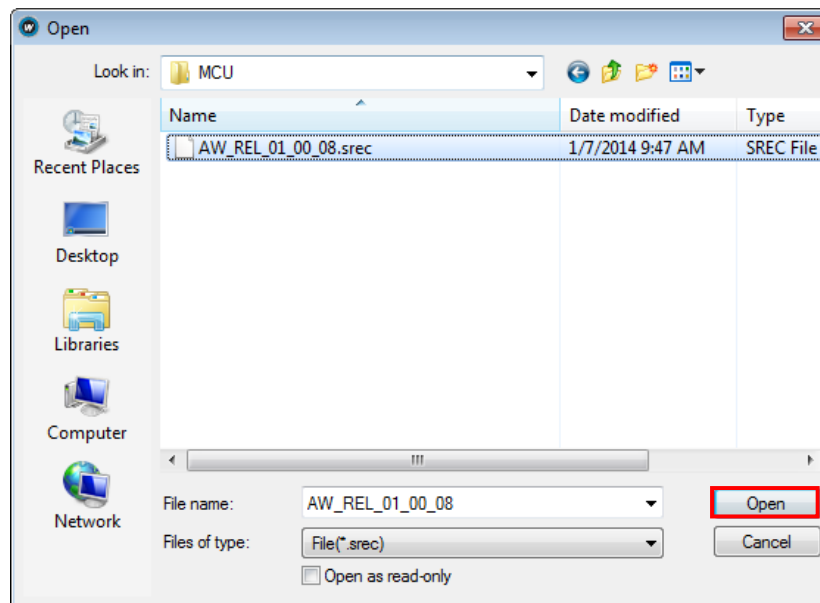

- Configurator starts downloading the MCU upgrade file to the camera and the download status is displayed at the bottom of the window. If you want to cancel the upgrade process, click the **Cancel** button. This process requires several minutes to complete.

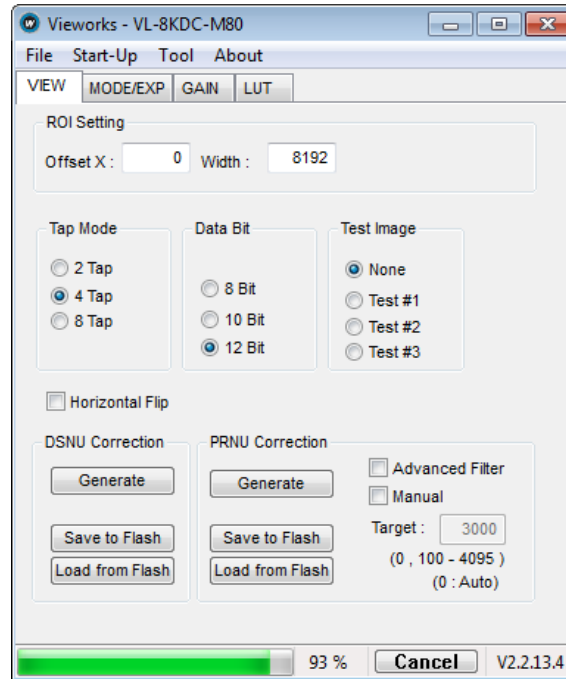

- Once the download has been completed, the saving process will begin. During the saving process, the camera cannot be restored if a power failure occurs. Make sure that the power connection is secured.

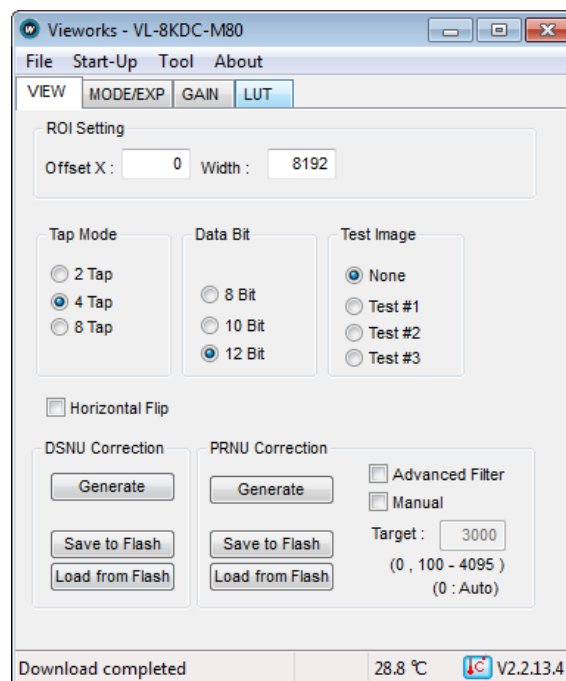

5. Once all processes have been completed, turn the power off and turn it back on again. Select **Tool > Terminal** and enter the 'gmv' command to confirm the version. You can also confirm the MCU version by selecting **About > Camera Info**.



A.2 FPGA

1. Select **File > System Upgrade > FPGA Upgrade** on Configurator.

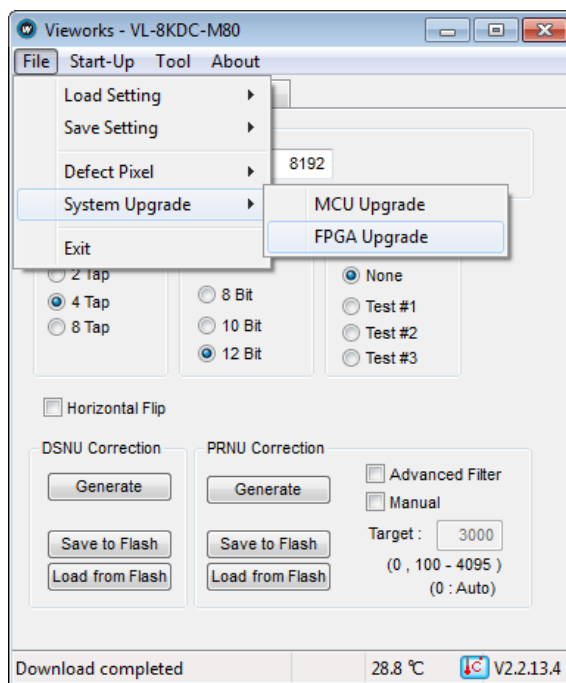

2. Locate the FPGA upgrade file (*.bin) and click the **Open** button.

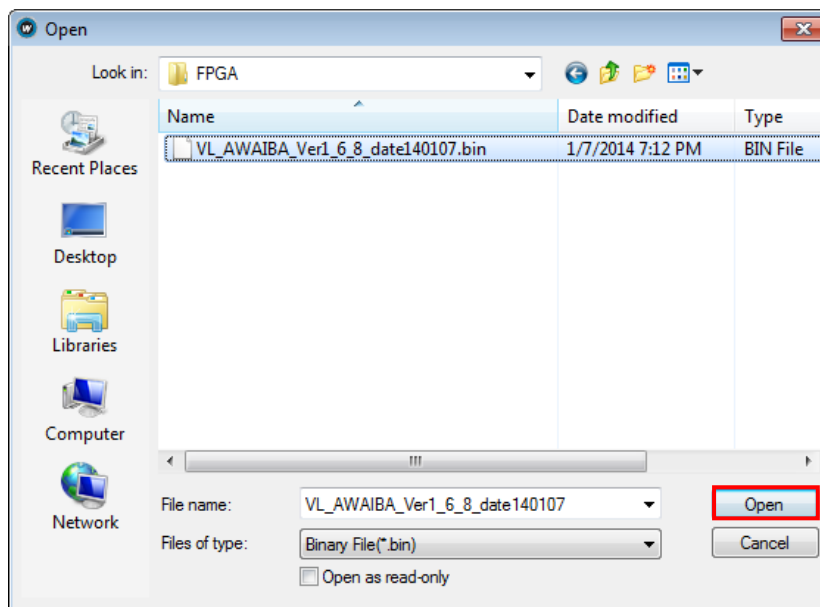

3. The subsequent processes are identical to those of MCU upgrade.

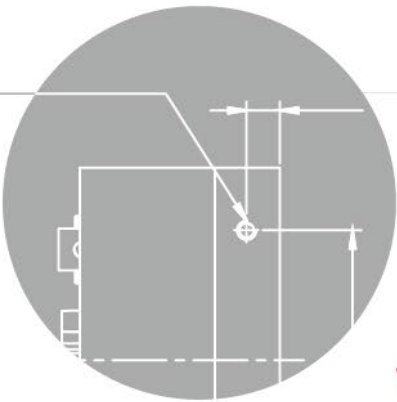
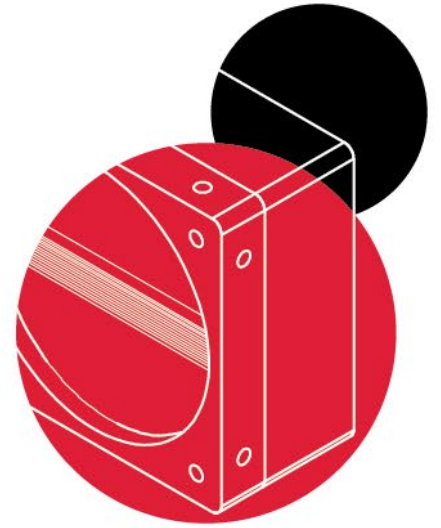
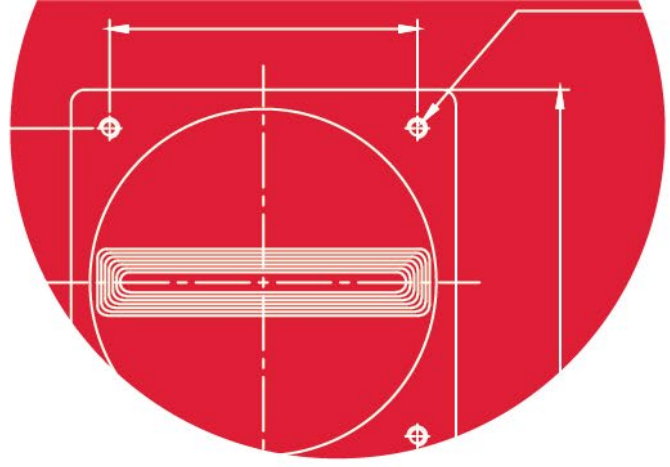

Vieworks Co., Ltd.

41-3, Burim-ro, 170beon-gil,
Dongan-gu, Anyang-si, Gyeonggi-do
14055 Republic of Korea

Tel: +82-70-7011-6161

Fax: +82-31-386-8631

<http://vision.vieworks.com>

vision@vieworks.com