

# VC series

## User Manual

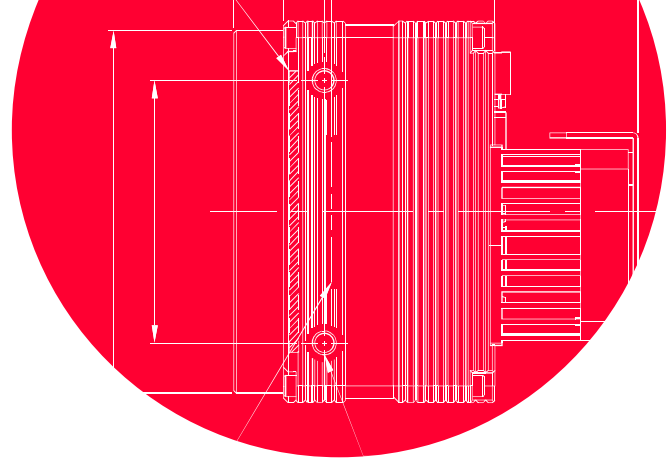

English

VC-103MC-M7I  
VC-103MC-C7I

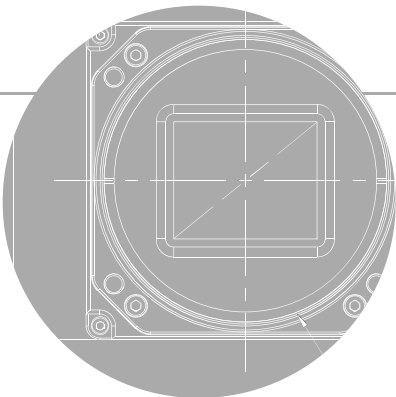

# VIEWWORKS



## **Preface**

No part of this manual may either be copied, reproduced, translated, or published in any form or by any means (electronic, mechanical, photocopying, or otherwise) without the express written permission of Vieworks, Co., Ltd. (hereinafter 'Vieworks').

This manual may include the website links to companies other than Vieworks. Vieworks is not responsible for any of these links. The copyrights of the materials mentioned herein are owned by each respective author.

Although Vieworks made every effort to ensure the accuracy of this document, it assumes no responsibility for errors or omissions that may appear herein. The figures in this manual may differ depending on the version of the product or operating system, or the way how it runs. Information in this manual is subject to change without notice.



## About This Manual

This manual is intended for VC-103MC-M/C7I™ camera users. It is recommended to refer to the Frame Grabber's User Manual of yours, with this manual.

## Convention in This Manual

For better understanding, the following conventions are used throughout the manual.

### Names and Fonts

The names and fonts of user interfaces are used as follows:

- The menu and icon names in this manual are used as displayed in the product.
- The menu and icon names are marked in **this font**.
- Button or keyboard key names are marked in this font.

### Warning, Caution, and Note

This manual shows warnings, cautions, and notes with the following figures:

**Warning!**

This indicates that you need to follow this message for your safety and to prevent the product from damage.

---

**Caution!**

This indicates that you need to follow this message to prevent data from being lost or corrupted.

---

**Note:**

This indicates that this message provides additional information.

---

## Definition of Terms

For clarity, this manual defines some terms as follows:

Term	Definition
Preface	The introductory part preceding the Table of Contents in this manual

## Revision History

This document has the revision history as follows:

Version	Date	Description
1.0	2022-04-15	Initial Release

## Contents

<b>Chapter 1. Precautions .....</b>	<b>15</b>
<b>Chapter 2. Warranty .....</b>	<b>16</b>
<b>Chapter 3. Compliance &amp; Certifications .....</b>	<b>17</b>
3.1    FCC Compliance .....	17
3.2    CE: DoC.....	17
3.3    KC .....	17
<b>Chapter 4. Package Component.....</b>	<b>18</b>
<b>Chapter 5. Product Specifications.....</b>	<b>19</b>
5.1    Overview .....	19
5.2    Specifications .....	20
5.3    Camera Block Diagram .....	21
5.4    Spectral Response .....	22
5.5    Mechanical Specification .....	23
5.5.1    Camera Mounting and Heat Dissipation .....	24
<b>Chapter 6. Connecting the Camera.....</b>	<b>25</b>
6.1    Precaution about Blurring Compared to the Center .....	26
6.2    Controlling the Camera .....	26
<b>Chapter 7. Camera Interface.....</b>	<b>27</b>
7.1    General Description.....	27
7.2    Camera Link SDR Connector.....	28
7.3    Power Input Receptacle.....	30
7.4    Control I/O Receptacle .....	31
7.5    Trigger Input Circuit.....	32
7.6    Output Circuit.....	32
<b>Chapter 8. Acquisition Control.....</b>	<b>33</b>
8.1    Overview .....	33
8.2    Acquisition Start/Stop Commands and Acquisition Mode.....	34
8.2.1    Acquisition Start/Stop Commands.....	34

8.2.2	Acquisition Mode.....	34
8.2.3	Exposure Start Trigger .....	35
8.2.4	Applying Trigger Signals .....	36
8.2.5	Exposure Time Control.....	36
8.3	Exposure Start Trigger .....	37
8.3.1	Trigger Mode .....	37
8.3.2	Using a Software Trigger Signal.....	40
8.3.3	Using a CC1 Trigger Signal.....	41
8.3.4	Using an External Trigger Signal .....	42
8.3.5	Exposure Mode .....	44
8.4	Setting the Exposure Time .....	46
8.5	Overlapping Exposure with Sensor Readout .....	47
8.6	Global Shutter .....	49
8.7	Maximum Allowed Frame Rate.....	50
8.7.1	Increasing the Maximum Allowed Frame Rate .....	51
<b>Chapter 9. Camera Features.....</b>		<b>52</b>
9.1	Sequence of Signal Processing .....	52
9.2	Image Region of Interest.....	53
9.3	Multi-ROI.....	56
9.4	Binning (Monochrome Only) .....	59
9.5	Camera Link Clock .....	61
9.6	Device Tap Geometry.....	62
9.7	Pixel Format.....	63
9.8	Data ROI (Color Only) .....	64
9.9	White Balance (Color Only).....	65
9.9.1	Balance White Auto .....	65
9.10	Gain .....	66
9.11	Black Level and Optical Black Correction .....	66
9.12	Defective Pixel Correction .....	70



9.13	Dark Signal Non-uniformity Correction .....	71
9.13.1	Generating and Saving User DSNU Correction Values .....	72
9.14	Photo Response Non-uniformity Correction .....	73
9.14.1	Generating and Saving User PRNU Correction Values .....	74
9.15	Flat Field Correction.....	75
9.15.1	Flat Field Data Selector .....	78
9.16	Timestamp.....	79
9.17	Event Control.....	79
9.18	Digital I/O Control .....	80
9.19	Debounce.....	82
9.20	Timer Control .....	83
9.21	Cooling Control.....	84
9.22	Temperature Monitor.....	85
9.23	Status LED .....	85
9.24	Test Pattern .....	86
9.25	Reverse X.....	89
9.26	Reverse Y.....	90
9.27	Device Link Throughput Limit .....	91
9.28	Device User ID .....	91
9.29	Device Reset .....	91
9.30	Field Upgrade.....	92
9.31	User Set Control.....	92
9.32	Sequencer Control .....	94
<b>Chapter 10. Camera Configuration .....</b>		<b>97</b>
10.1	Serial Communication.....	97
10.2	Actual Runtime of Parameters .....	97
10.3	Configurator .....	99
10.3.1	Starting the Configurator .....	99
10.4	Command List .....	102
<b>Chapter 11. Troubleshooting .....</b>		<b>108</b>
<b>Appendix A. Defective Pixel Map Download .....</b>		<b>109</b>

**Appendix B. Field Upgrade.....111**  
**Appendix C. Index .....112**

## Tables

Table 5-1	Specification of VC-103MC-M/C7I.....	20
Table 7-1	Pin Assignments for Camera Link Connector 1.....	28
Table 7-2	Pin Assignments for Camera Link Connector 2.....	29
Table 7-3	Connector Arrangement for the Device Tap Geometry .....	29
Table 7-4	Pin Configurations for Power Input Receptacle .....	30
Table 7-5	Pin Configurations for Control I/O Receptacle.....	31
Table 8-1	Minimum and Maximum Exposure Time Setting .....	46
Table 9-1	XML Parameters related to ROI .....	54
Table 9-2	Minimum ROI Width and Height Settings.....	54
Table 9-3	Maximum Frame Rates depending on ROI Changes.....	55
Table 9-4	XML parameters related to Multi-ROI.....	56
Table 9-5	XML Parameters related to Binning .....	59
Table 9-6	XML Parameters related to Camera Link Clock Speed.....	61
Table 9-7	XML Parameter related to Device Tap Geometry .....	62
Table 9-8	XML Parameter related to Pixel Format .....	63
Table 9-9	Pixel Format Values .....	63
Table 9-10	XML Parameters related to Data ROI.....	64
Table 9-11	XML Parameters related to White Balance.....	65
Table 9-12	XML Parameter related to Balance White Auto.....	65
Table 9-13	XML Parameters related to Gain .....	66
Table 9-14	XML Parameters related to Black Level.....	69
Table 9-15	Commands related to Dynamic Defective Pixel Correction.....	70
Table 9-16	Calculation of Defect Pixel Correction Value .....	70
Table 9-17	XML Parameters related to DSNU .....	71

Table 9-18	XML Parameters related to PRNU .....	73
Table 9-19	XML Parameters related to Flat Field Correction.....	77
Table 9-20	XML Parameters related to Timestamp.....	79
Table 9-21	XML Parameters related to Event Control.....	79
Table 9-22	XML Parameters related to Digital I/O Control .....	80
Table 9-23	XML Parameter related to Debounce Time .....	82
Table 9-24	XML Parameters related to Timer Control.....	83
Table 9-25	XML Parameters related to Cooling Control.....	84
Table 9-26	XML Parameters related to Device Temperature.....	85
Table 9-27	Status LED .....	85
Table 9-28	XML Parameter related to Test Pattern.....	86
Table 9-29	XML Parameter related to Reverse X.....	89
Table 9-30	XML Parameter related to Reverse Y .....	90
Table 9-31	XML Parameter related to Device Link Throughput Limit .....	91
Table 9-32	XML Parameter related to Device User ID.....	91
Table 9-33	XML Parameter related to Device Reset .....	91
Table 9-34	XML Parameters related to User Set Control.....	92
Table 9-35	XML Parameters related to Sequencer Control .....	94
Table 10-1	Command List #1 .....	102
Table 10-2	Command List #2 .....	103
Table 10-3	Command List #3 .....	104
Table 10-4	Command List #4 .....	105
Table 10-5	Command List #5 .....	106
Table 10-6	Command List #6 .....	107

## Figures

Figure 5-1	Camera Block Diagram.....	21
Figure 5-2	VC-103MC-M/C7I Spectral Response .....	22
Figure 5-3	VC-103MC-M/C7I Mechanical Dimension .....	23
Figure 7-1	VC-103MC-M/C7I Back Panel.....	27
Figure 7-2	Micro-BNC Connector .....	28
Figure 7-3	Pin Assignments for Power Input Receptacle .....	30
Figure 7-4	Pin Assignments for Control I/O Receptacle.....	31
Figure 7-5	Input Schematic .....	32
Figure 7-6	Output Schematic.....	32
Figure 8-1	Exposure Start Triggering.....	35
Figure 8-2	Frame Acquisition with Software Trigger Signal .....	40
Figure 8-3	External Trigger Delay .....	43
Figure 8-4	Timed Exposure Mode .....	44
Figure 8-5	Trigger Overlapped with Timed Exposure Mode .....	44
Figure 8-6	TriggerWidth Exposure Mode .....	45
Figure 8-7	Overlapped Exposure and Readout .....	47
Figure 8-8	Global Shutter .....	49
Figure 9-1	Sequence of signal processing to correct images .....	52
Figure 9-2	Region of Interest.....	53
Figure 9-3	Multi-ROI.....	57
Figure 9-4	2 × 2 Binning and 4 × 4 Binning.....	60
Figure 9-5	Device Tap Geometry .....	62
Figure 9-6	VC-103MC-M/C7I' Pixel Format .....	63
Figure 9-7	Effective Data ROI.....	64

---

Figure 9-8	Sequence of signal processing and Black Level .....	68
Figure 9-9	Location of Defect Pixel to be corrected .....	70
Figure 9-10	Generation and Application of Flat Field Data.....	76
Figure 9-11	Bilinear Interpolated Magnification .....	76
Figure 9-12	Flat Field Data Selector.....	78
Figure 9-13	User Output .....	80
Figure 9-14	Exposure Active Signal.....	81
Figure 9-15	Debounce .....	82
Figure 9-16	Timer Signal.....	84
Figure 9-17	Grey Horizontal Ramp.....	86
Figure 9-18	Grey Diagonal Ramp.....	87
Figure 9-19	Grey Diagonal Ramp Moving.....	87
Figure 9-20	Sensor Specific .....	88
Figure 9-21	Original Image .....	89
Figure 9-22	Reverse X Image.....	89
Figure 9-23	Original Image .....	90
Figure 9-24	Reverse Y Image.....	90
Figure 9-25	User Set Control.....	93
Figure 9-26	Sequencer Diagram (Use Case).....	96
Figure 10-1	Actual Runtime of Parameters .....	98
Figure 10-2	Add to list in the Camera Scan window.....	99
Figure 10-3	Device Property .....	100
Figure 10-4	Configurator Plus and Device Maintenance.....	101

## Chapter 1. Precautions

### General



- Do not drop, disassemble, repair or alter the device. Doing so may damage the camera electronics and cause an electric shock.
- Do not let children or companion animals touch the device without supervision.
- Stop using the device and contact the nearest dealer or manufacturer for technical assistance if liquid such as water, drinks or chemicals gets into the device.
- Do not touch the device with wet hands. Doing so may cause an electric shock.
- Make sure that the temperature of the camera does not exceed the temperature range specified in [5.2 Specification](#). Otherwise the device may be damaged by extreme temperature.

### Installation and Maintenance



- Do not install in dusty or dirty areas - or near an air conditioner or heater to reduce the risk of damage to the device.
- Avoid installing and operating in an extreme environment where vibration, heat, humidity, dust, strong magnetic fields, explosive/corrosive mists or gases are present.
- Do not apply excessive vibration and shock to the device. This may damage the device.
- Avoid direct exposure to a high intensity light source. This may damage the image sensor.
- Do not install the device under unstable lighting conditions. Severe lighting change will affect the quality of the image produced by the device.
- Do not use solvents or thinners to clean the surface of the device. This can damage the surface finish.

### Power Supply



- Applying incorrect power can damage the camera. If the voltage applied to the camera is greater or less than the camera's nominal voltage, the camera may be damaged or operate erratically. Please refer to [5.2 Specifications](#) for the camera's nominal voltage.
  - ※ Vieworks Co., Ltd. does NOT provide power supplies with the device.
- Make sure the power is turned off before connecting the power cord to the camera. Otherwise damage to the camera may result.

## Chapter 2. Warranty

Do not open the housing of the camera. The warranty becomes void if the housing is opened. For information about the warranty, please contact your local dealer or factory representative.



## Chapter 3. Compliance & Certifications

### 3.1 FCC Compliance

This equipment has been tested and found to comply with the limits for a Class A digital device, pursuant to part 15 of the FCC Rules. These limits are designed to provide reasonable protection against harmful interference when the equipment is operated in a commercial environment. This equipment generates, uses, and can radiate radio frequency energy and, if not installed and used in accordance with the instruction manual, may cause harmful interference to radio communications. Operation of this equipment in a residential area is likely to cause harmful interference in which case the user will be required to correct the interference at his own expenses.

### 3.2 CE: DoC

EMC Directive 2014/30/EU  
EN 55032:2012 (Class A), EN 55024:2010  
Class A

### 3.3 KC

#### KCC Statement

Type	Description
Class A (Broadcasting Communication Device for Office Use)	This device obtained EMC registration for office use (Class A), and may be used in places other than home. Sellers and/or users need to take note of this.

## Chapter 4. Package Component

---

Package Component



VC-103MC-M/C7I

---

## Chapter 5. Product Specifications

### 5.1 Overview

The VC-103MC-M/C7I, the latest model of the industrial proven VC series, is 103 megapixel resolution CMOS cameras available with the Camera Link interface. These cameras are based on the latest CMOS image sensor technology (GMAX32103) from Gpixel. The VC-103MC-7 offers up to 7.6 frames per second at 11264 × 9200 resolution. Equipped with the Viewworks' innovative technologies proved by world's top FPD manufacturers, the VC-103MC camera offers not only highly uniformed images but also high speed image processing capabilities. Featured with high quality image uniformity and high resolution, these cameras are ideal for demanding applications such as FPD, PCB and semiconductor inspections.

#### Main Features

- High Speed 103 Megapixel CMOS Image Sensor
- Output Pixel Format: 8/10/12 bit
- Strobe Output
- Dynamic Defective Pixel Correction
- Camera Link Base/Medium/Full/10-taps
- Camera Link Tap Geometry: 2/4/8/10 Taps
- Camera Link Clock Frequency Selector
- Gain / Black Level Control
- Test Image
- LVDS (RS-644) Serial Communication by Camera Link Interface
- Temperature Monitor
- Field Upgrade
- DSNU and PRNU Correction
- Flat Field Correction with Sequencer Control
- Hot Pixel Correction
- GenICam Compatible – XML based Control

## 5.2 Specifications

The technical specifications of the VC-103MC-M/C7I camera are as follows.

Specifications		VC-103MC-M/C7I
Active Image (H×V)		11264 × 9200
Sensor		Gpixel GMAX32103
Optical Format (Diagonal)		36.1 mm × 29.4 mm (photo sensitive area)
Pixel Size		3.2 μm × 3.2 μm
Interface		Camera Link Base/Medium/Full/10-taps, 26-pin SDR Connector× 2
Electronic Shutter		Global Shutter
Max.	4 Taps	3.0 fps
Frame Rate (8 bit)	8 Taps	6.1 fps
	10 Taps	7.6 fps
Pixel Data Format	Mono	Mono 8/10/12 bit
	Color	GB Bayer 8/10/12 bit
Exposure Time		1 μs ~ 60 s (1 μs step)
Partial Scan (Max. Speed)		224.8 fps at 4 lines
Binning		×1, ×2, ×4(Monochrome), Horizontal and Vertical Independent
Black Level Control		0 ~ 255 LSB at 12 bit
Gain Control	Analog	1.4× ~ 5.2×
	Digital	1.0× ~ 32.0×
Trigger Synchronization		Free-Run, Hardware Trigger or Software Trigger
External Trigger		3.3 V ~ 24.0 V, 10 mA, Logical Level Input, Optically Isolated
Software Trigger		Asynchronous, Programmable via Camera API
Dynamic Range		66 dB
Lens Mount		M72-mount
Power	External	11 ~ 24 V DC
	Dissipation	Typical 16 W, Maximum 20 W
Temperature		Operating: 0 ~ 40°C, Storage: -40°C ~ 70°C
Dimension / Weight		80 mm × 80 mm × 85 mm, 0.55 kg (with M72-mount)

Table 5-1 Specification of VC-103MC-M/C7I

### 5.3 Camera Block Diagram

The block diagram of the VC-103MC-M/C7I is shown below.

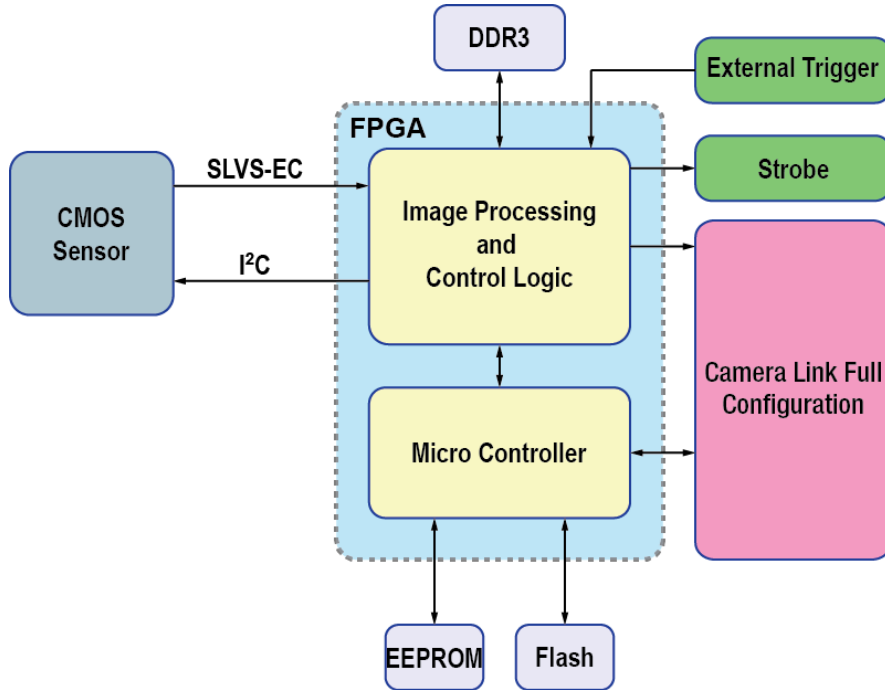

Figure 5-1 Camera Block Diagram

All controls and data processing of the VC-103MC-M/C7I camera are carried out in one FPGA chip. The FPGA generally consists of a 32-bit RISC Micro-Controller and Processing & Control logic. The Micro-Controller receives commands from the user through the 10 GigE interface and then processes them. The Processing & Control logic processes the image data received from the CMOS image sensor and then transmits data through the 10 GigE interface. The Processing & Control logic also controls time-sensitive trigger inputs and output signals. Furthermore, Flash and DDR3 are installed outside FPGA. The DDR3 is used for the frame buffer to process images and the Flash stores the firmware to operate the Micro-Controller.

## 5.4 Spectral Response

The following graphs show the spectral response of the VC-103MC-M/C7I color and monochrome cameras.

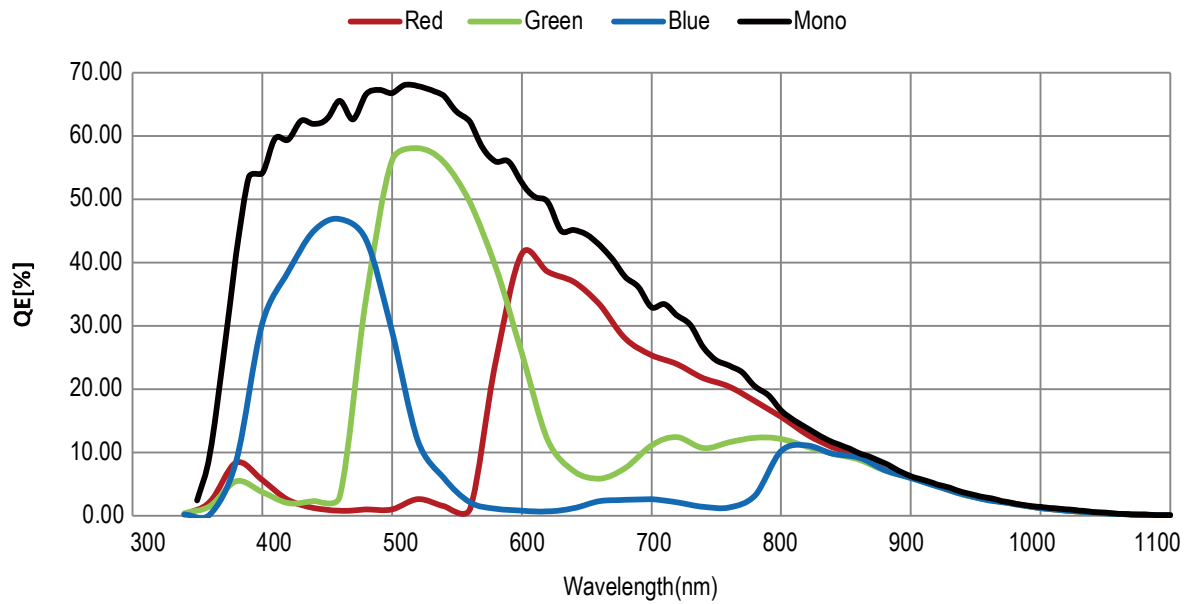

Figure 5-2 VC-103MC-M/C7I Spectral Response

### 5.5 Mechanical Specification

The camera dimensions in millimeters are shown in the following figure.

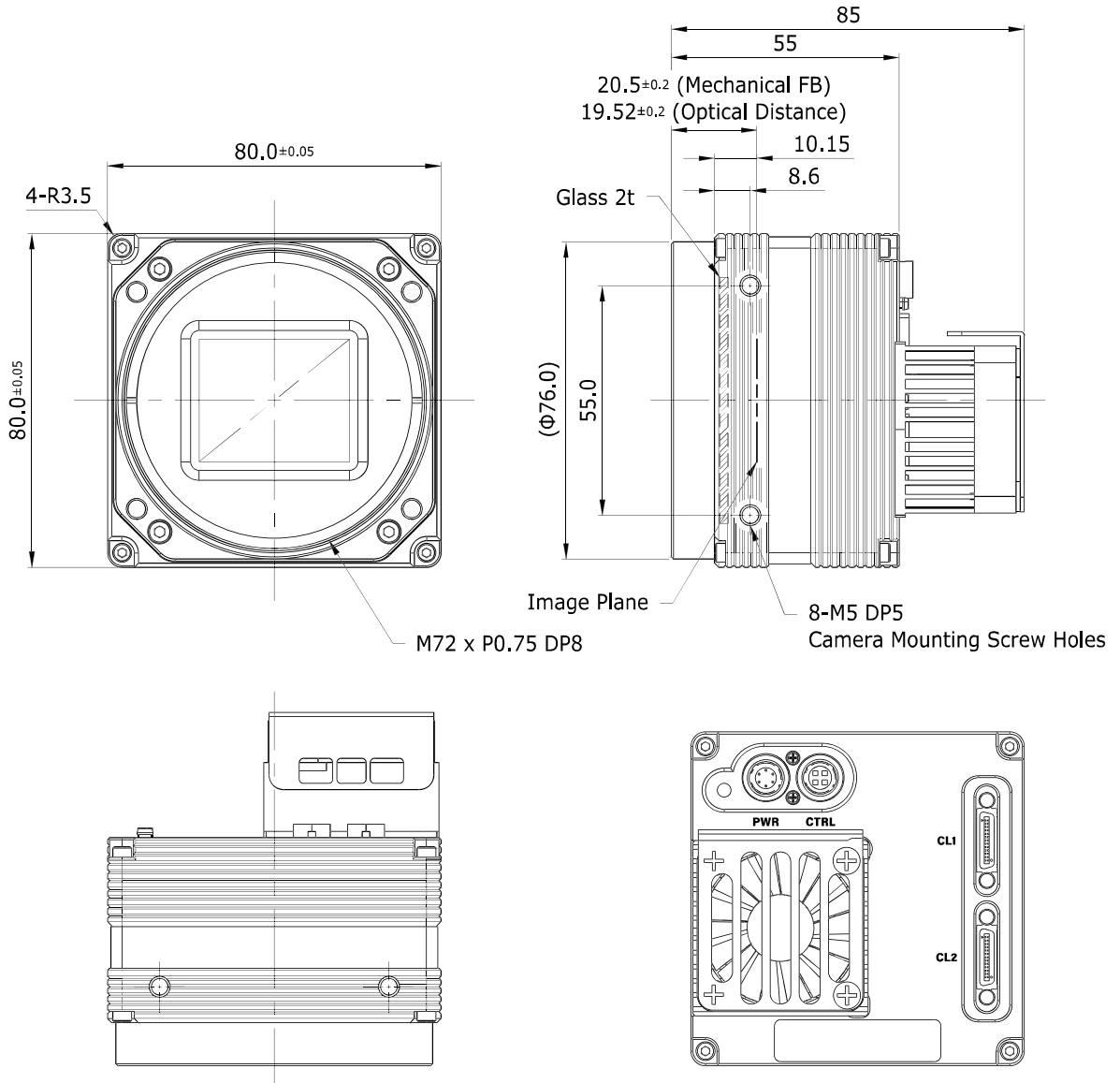

Figure 5-3 VC-103MC-M/C7I Mechanical Dimension

## 5.5.1 Camera Mounting and Heat Dissipation

### Camera Mounting Recommendations for Antivibration

When you mount a camera in a poor condition, the fan equipped on the camera may amplify vibrations which can lead to blurry images. Follow the instructions below to prevent and/or reduce vibrations caused by the fan.

- Fix the camera's front or side surface by using at least four screws.
- Prevent ingress of foreign objects between the camera and system surfaces.
- Keep the camera's center of gravity as near as possible to the system's center of gravity.
- If your lens' weight or size is greater than the camera's, make and use proper mounting brackets to support the lens.
- Prevent foreign matters from falling into the fan. This may cause damage to the fan blades.

### Camera Mounting Recommendations for Effective Heat Dissipation

- Do not obstruct the air inlets and outlets of the fan.
- If the fan is not available, leave enough space around the heat sink so that heat can be easily dissipated through the heat sink by natural convection.
- If the fan is not available, mount the camera on a metal structure made of high thermal conductive materials (e.g. Aluminum) to properly dissipate the heat generated by the camera.
- The contact surface of the camera must be at least 30% of the camera's Front-Block.



## Chapter 6. Connecting the Camera

The following instructions assume that you have installed a Camera Link frame grabber in your computer including related software. For more information, refer to your Camera Link frame grabber user manual.

To connect the camera to your computer, follow the steps below:

1. Make sure that the power supply is not connected to the camera and your computer is turned off.
2. Plug one end of a Camera Link cable into the Camera Link1 connector on the camera and the other end of the Camera Link cable into the Base connector on the Camera Link frame grabber.
3. Plug one end of the other Camera Link cable into the Camera Link2 connector on the camera and the other end of the Camera Link cable into the Medium/Full connector on the Camera Link frame grabber.
4. Connect the plug of the power adapter to the power input receptacle on the camera.
5. Plug the power adapter into a working electrical outlet.
6. Verify all the cable connections are secure.

### Precautions for using Camera Link Medium/Full/10-taps Configuration



#### Caution!

- The VC-103MC-M/C7I supports the Camera Link Base / Medium / Full / 10-taps configuration. To operate the camera in the medium, full or 10-taps configuration, you must connect the camera to the Camera Link frame grabber using two Camera Link cables. Make sure that you connect both Camera Link1 (Base) and Camera Link2 (Medium/Full) connectors on the camera to their respective connectors on the Camera Link frame grabber.
  - Depending on the type of the frame grabber in use, images acquired may not appear correctly in the 10-taps mode, sometimes. Therefore, it is recommended to use the latest Camera Link frame grabber.
-

## 6.1 Precaution about Blurring Compared to the Center

- Users do not need to adjust the tilt as it is adjusted as factory default settings.
- If the tilt settings need to be adjusted inevitably, please contact your local dealer or factory representative for technical support.

## 6.2 Controlling the Camera

- You can control the camera by using the Configurator.
- You may be able to download the latest Configurator by contacting the manufacturer of your frame grabber.
- Please refer to your Camera Link frame grabber user manual.

## Chapter 7. Camera Interface

### 7.1 General Description

As shown in the following figure, three types of connectors and an LED indicator are located on the back of the camera and have the functions as follows:

- ① Status LED: displays power status and operation mode.
- ② 6-pin Power Input Receptacle: supplies power to the camera (if PoCXP is not used).
- ③ 4-pin Control I/O Receptacle: provides access to the camera's I/O lines.
- ④ 26 pin SDR Connector 1 (Camera Link Base): transmits video data and controls the camera.
- ⑤ 26 pin SDR Connector 2 (Camera Link Medium/Full): transmits video data.

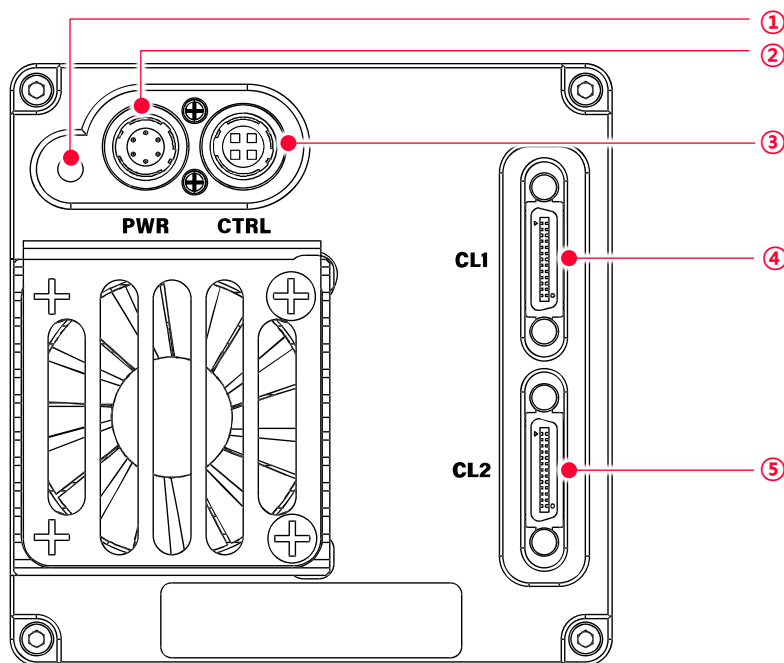

Figure 7-1 VC-103MC-M/C7I Back Panel

## 7.2 Camera Link SDR Connector

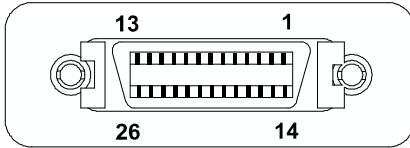

Figure 7-2 Micro-BNC Connector

The Camera Link connectors on the camera comply with the Camera Link standard and the following lists show the pin assignments of the connectors.

PAIR List	Pin	Signal Name	Type	Description
PAIR 0	1	Ground	Ground	Cable Shield
	14	Ground	Ground	Cable Shield
PAIR 1	2	-X0	LVDS - Out	Camera Link Transmitter
	15	+X0	LVDS - Out	Camera Link Transmitter
PAIR 2	3	-X1	LVDS - Out	Camera Link Transmitter
	16	+X1	LVDS - Out	Camera Link Transmitter
PAIR 3	4	-X2	LVDS - Out	Camera Link Transmitter
	17	+X2	LVDS - Out	Camera Link Transmitter
PAIR 4	5	-XCLK	LVDS - Out	Camera Link Transmitter
	18	+XCLK	LVDS - Out	Camera Link Transmitter
PAIR 5	6	-X3	LVDS - Out	Camera Link Transmitter
	19	+X3	LVDS - Out	Camera Link Transmitter
PAIR 6	7	+ SerTC	LVDS - In	Serial Data Receiver
	20	- SerTC	LVDS - In	Serial Data Receiver
PAIR 7	8	- SerTFG	LVDS - Out	Serial Data Transmitter
	21	+ SerTFG	LVDS - Out	Serial Data Transmitter
PAIR 8	9	- CC 1	LVDS - In	Software External Trigger
	22	+ CC 1	LVDS - In	Software External Trigger
PAIR 9	10	N/C	N/C	N/C
	23	N/C	N/C	N/C
PAIR 10	11	N/C	N/C	N/C
	24	N/C	N/C	N/C
PAIR 11	12	N/C	N/C	N/C
	25	N/C	N/C	N/C
PAIR 12	13	Ground	Ground	Cable Shield
	26	Ground	Ground	Cable Shield

Table 7-1 Pin Assignments for Camera Link Connector 1

PAIR List	Pin	Signal Name	Type	Description
PAIR 0	1	Ground	Ground	Cable Shield
	14	Ground	Ground	Cable Shield
PAIR 1	2	-Y0	LVDS - Out	Camera Link Transmitter
	15	+Y0	LVDS - Out	Camera Link Transmitter
PAIR 2	3	-Y1	LVDS - Out	Camera Link Transmitter
	16	+Y1	LVDS - Out	Camera Link Transmitter
PAIR 3	4	-Y2	LVDS - Out	Camera Link Transmitter
	17	+Y2	LVDS - Out	Camera Link Transmitter
PAIR 4	5	-YCLK	LVDS - Out	Camera Link Transmitter
	18	+YCLK	LVDS - Out	Camera Link Clock Tx
PAIR 5	6	-Y3	LVDS - Out	Camera Link Channel Tx
	19	+Y3	LVDS - Out	Camera Link Channel Tx
PAIR 6	7	-	Not Used	Connected with 100 ohm
	20	-	Not Used	
PAIR 7	8	-Z0	LVDS - Out	Camera Link Transmitter
	21	+Z0	LVDS - Out	Camera Link Transmitter
PAIR 8	9	-Z1	LVDS - Out	Camera Link Transmitter
	22	+Z1	LVDS - Out	Camera Link Transmitter
PAIR 9	10	-Z2	LVDS - Out	Camera Link Transmitter
	23	+Z2	LVDS - Out	Camera Link Transmitter
PAIR 10	11	-ZCLK	LVDS - Out	Camera Link Transmitter
	24	+ZCLK	LVDS - Out	Camera Link Clock Tx
PAIR 11	12	-Z3	LVDS - Out	Camera Link Channel Tx
	25	+Z3	LVDS - Out	Camera Link Channel Tx
PAIR 12	13	Ground	Ground	Cable Shield
	26	Ground	Ground	Cable Shield

Table 7-2 Pin Assignments for Camera Link Connector 2

Model	Device Tap Geometry	CL Configuration	CL Connector 1	CL Connector 2
VC-103MC-M/C7I	2 Taps	BASE	○	X
	4 Taps	MEDIUM	○	○
	8 Taps	FULL	○	○
	10 Taps	10-taps	○	○

Table 7-3 Connector Arrangement for the Device Tap Geometry

**Note:**

When you connect a Camera Link frame grabber to the Camera Link connectors on the camera using Camera Link cables, make sure you connect the cables to their correct connectors. If you connect the Camera Link connector 1 on the camera to a connector other than connector 1 of the Camera Link frame grabber, the camera may not transmit images correctly or the serial communication between the camera and the computer may fail.

### 7.3 Power Input Receptacle

The power input and control I/O receptacle is a 6-pin connector (part # HR10A-7R-6PB). The pin assignments and configurations are as follows:

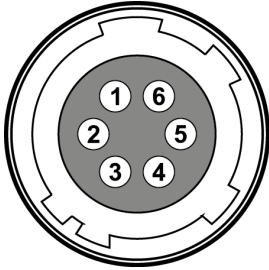

Figure 7-3 Pin Assignments for Power Input Receptacle

Pin Number	Signal	Type	Description
1, 2, 3	+12 V DC	Input	DC Power Input
4, 5, 6	DC Ground	Input	DC Ground

Table 7-4 Pin Configurations for Power Input Receptacle



**Note:**

- A recommended mating connector for the Hirose 6-pin connector is the Hirose 6-pin plug (part # HR10A-7P-6S) or the equivalent.
- It is recommended that you use the power adapter, which has at least 3 A current output at 10 – 24 V voltage output (You need to purchase a power adapter separately).

#### Precaution for Power Input



**Caution!**

- Make sure the power is turned off before connecting the power cord to the camera. Otherwise, damage to the camera may result.
- If the voltage applied to the camera is greater than specified in the specifications, damage to the camera may result.

## 7.4 Control I/O Receptacle

The Control I/O receptacle is a Hirose 4-pin connector (part # HR10A-7R-4S) and consists of an external trigger signal input and strobe output ports. The pin assignments and configurations are as follows:

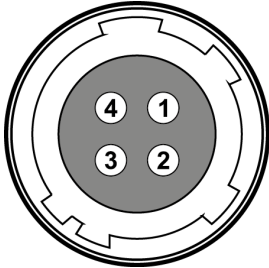

Figure 7-4 Pin Assignments for Control I/O Receptacle

Pin Number	Signal	Type	Description
1	Trigger Input+	Input	3.3 V – 24.0 V TTL Input
2	Trigger Input-	Input	-
3	DC Ground	-	DC Ground
4	Line1 Output	Output	3.3 V TTL Output Output Resistance: 47 $\Omega$

Table 7-5 Pin Configurations for Control I/O Receptacle



**Note:**

A recommended mating connector for the Hirose 4-pin connector is the Hirose 4-pin plug (part # HR10A-7P-4P) or the equivalent.

### 7.5 Trigger Input Circuit

The following figure shows trigger signal input circuit of the 4-pin connector. Transmitted trigger signal is applied to the internal circuit through a photo coupler. With the Debounce feature, you can specify the width of input signal to be considered as a valid input signal. An external trigger circuit example is shown below.

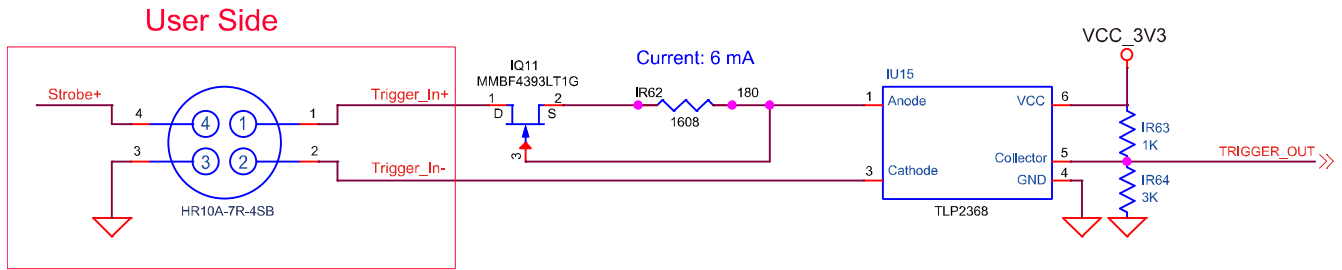

Figure 7-5 Input Schematic

### 7.6 Output Circuit

The output signal comes out through a 3.3 V output level of TTL Driver IC. You can configure the output line by setting the Digital I/O Control (refer to 9.18 Digital I/O Control).

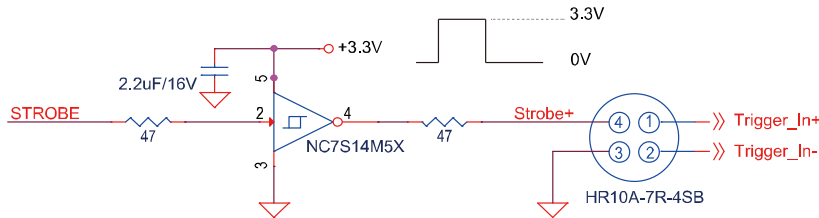

Figure 7-6 Output Schematic



## Chapter 8. Acquisition Control

This chapter provides detailed information about controlling image acquisition.

- Triggering image acquisition
- Setting the exposure time
- Controlling the camera's image acquisition rate
- Variation of the camera's maximum allowed image acquisition rate according to the camera settings

### 8.1 Overview

This section presents an overview of the elements involved with controlling the acquisition of images.

The followings are involved in controlling the acquisition of images.

- Acquisition Start and Acquisition Stop commands and the Acquisition Mode parameter
- Exposure start trigger
- Exposure time control
- Frame acquisition process on the camera
- Global shutter
- Maximum Allowed Frame Rate



**Note:**

A recommended mating connector for the Hirose 4-pin connector is the Hirose 4-pin plug (part # HR10A-7P-4P) or the equivalent.

---

## 8.2 Acquisition Start/Stop Commands and Acquisition Mode

This section describes function available to use via the followings:

- Acquisition Start/Stop commands
- Acquisition Mode

The details about each item above is described in the order from the following section.

### 8.2.1 Acquisition Start/Stop Commands

The **Acquisition Start** command prepares the camera to acquire images. The camera cannot acquire images unless an **Acquisition Start** command has first been executed.

Executing an **Acquisition Stop** command terminates the camera's ability to acquire images.

### 8.2.2 Acquisition Mode

The **Acquisition Mode** parameter affects directly how the **Acquisition Start** command works. There are three of types available to select in this parameter as follows:

- Continuous:  
Acquires frames continuously once the **Acquisition Start** command is called until the **Acquisition Stop** command is called.
- SingleFrame:  
Acquires one single frame after the **Acquisition Start** command is called, and then, finishes acquiring images with calling the **Acquisition Stop** command automatically.
- MultiFrame:  
Acquires frames as many as the numbers designated on the **AcquisitionFrameCount** parameter after the **Acquisition Start** command is called, and then, finishes acquiring images with calling the **Acquisition Stop** command automatically.

**Note:**

The **Acquisition Start** command will remain in effect until you execute an **Acquisition Stop** command. Once an **Acquisition Stop** command has been executed, the camera will not be able to acquire frames until a new **Acquisition Start** command is executed. If a user calls an **Acquisition Stop** command on the way of image acquisition, the work will finish after finishing the ongoing acquisition all.

---

### 8.2.3 Exposure Start Trigger

Applying an exposure start trigger signal to the camera will exit the camera from the waiting for exposure start trigger acquisition status and will begin the process of exposing and reading out a frame (see [Figure 8-1](#)). As soon as the camera is ready to accept another exposure start trigger signal, it will return to the waiting for exposure start trigger acquisition status. A new exposure start trigger signal can then be applied to the camera to begin another frame exposure. The exposure start trigger has two modes: off and on.

If the **Trigger Mode** parameter is set to **Off**, the camera will generate all required exposure start trigger signals internally, and you do not need to apply exposure start trigger signals to the camera. The rate at which the camera will generate the signals and acquire frames will be determined by the way that you set several frame rate related parameters.

If the **Trigger Mode** parameter is set to **On**, you must trigger exposure start by applying exposure start trigger signals to the camera. Each time a trigger signal is applied, the camera will begin a frame exposure. When exposure start is being triggered in this manner, it is important that you do not attempt to trigger frames at a rate that is greater than the maximum allowed (There is a detailed explanation about the maximum allowed frame rate at the end of this chapter.). Exposure start trigger signals applied to the camera when it is not in a waiting for exposure start trigger acquisition status will be ignored.

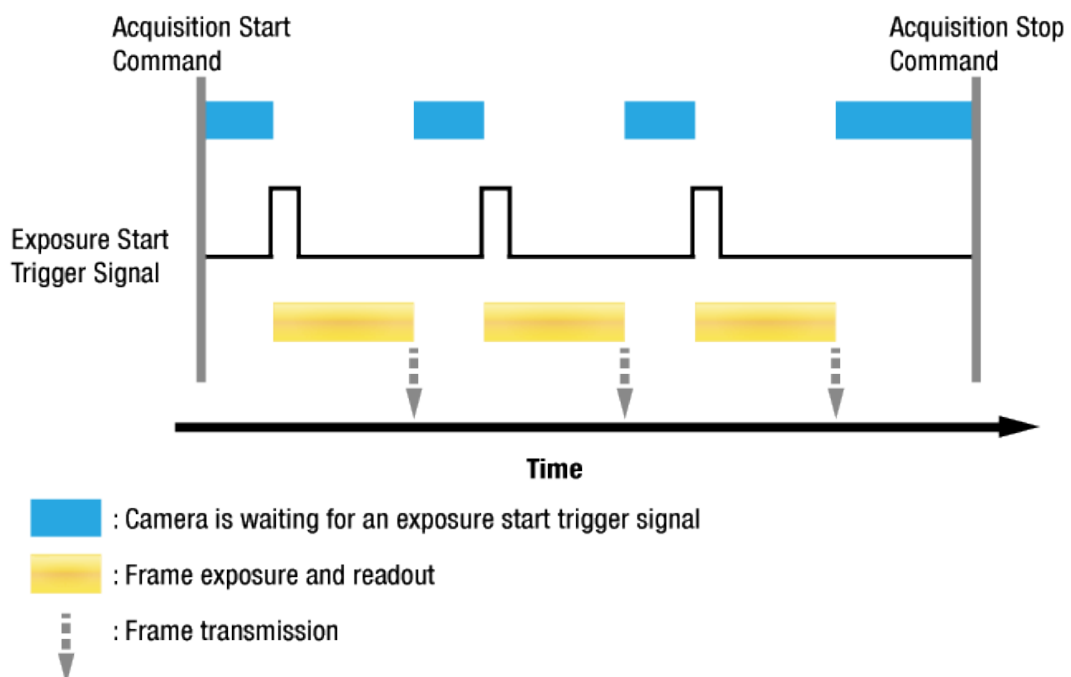

Figure 8-1 Exposure Start Triggering

## 8.2.4 Applying Trigger Signals

The paragraphs above mention “applying a trigger signal”. There are five ways to apply an exposure start trigger signal to the camera: via **Software**, via **UserOutput0**, via **CC1**, via **Time0Active**, or via **Line0** (commonly referred to a hardware).

- To apply trigger signals via **Software**, you must set the **Trigger Source** parameter to **Software**. At that point, each time a **Trigger Software** command is executed, the exposure start trigger signal will be applied to the camera.
- To apply trigger signals via **UserOutput0**, you must set the **Trigger Source** parameter to **UserOutput0**. At that point, you can apply an exposure start trigger signal to the camera by switching the **User Output Value** parameter between **On** (rise) and **Off** (fall).
- To apply trigger signals via Camera Link frame grabber, you must set the **Trigger Source** parameter to **CC1**. At that point, each time an externally generated electrical signal is applied to the camera by using the APIs provided by a Camera Link frame grabber manufacturer, the exposure start trigger signal will be applied to the camera. For more information, refer to your Camera Link frame grabber user manual.
- To apply trigger signals via the user-defined Timer feature, you must set the **Trigger Source** parameter to **Timer0 Active**. When you set the **Timer Trigger Source** parameter to **Line0** in the **Counter And Timer Control** category, you can apply an exposure start trigger signal to the camera by using a Timer that uses the Line0 signal as the source signal.
- To apply trigger signals via hardware (external), you must set the **Trigger Source** parameter to **Line0**. At that point, each time a proper electrical signal is applied to the camera, an occurrence of the exposure start trigger signal will be recognized by the camera.

## 8.2.5 Exposure Time Control

When an exposure start trigger signal is applied to the camera, the camera will begin to acquire a frame. A critical aspect of frame acquisition is how long the pixels in the camera’s sensor will be exposed to light during the frame acquisition. If the **Trigger Source** parameter is set to **UserOutput0**, **CC1**, **Timer0Active**, or **Line0**, there are two modes of operation: **Timed** and **TriggerWidth**.

With the **Timed** mode, the **Exposure Time** parameter will determine the exposure time for each frame. With the **TriggerWidth** mode, the way that you manipulate the rise and fall of the **User Output**, **CC1** or hardware (external) signal will determine the exposure time. The **TriggerWidth** mode is especially useful if you want to change the exposure time from frame to frame.

## 8.3 Exposure Start Trigger

The **Trigger Selector** parameter is used to select a type of trigger and only the **Exposure Start** trigger is available on the VC-103MC-M/C7I camera. The Exposure Start trigger is used to begin frame acquisition. Exposure start trigger signals can be generated within the camera or may be applied externally by setting the **Trigger Source** parameter to **Software**, **UserOutput0**, **CC1**, **Time0Active**, or **Line0**. If an exposure start trigger signal is applied to the camera, the camera will begin to expose a frame.

### 8.3.1 Trigger Mode

The main parameter associated with the exposure start trigger is the **Trigger Mode** parameter. The **Trigger Mode** parameter for the exposure start trigger has two available settings: **Off** and **On**.

#### Trigger Mode = Off

When the **Trigger Mode** parameter is set to **Off**, the camera will generate all required exposure start trigger signals internally, and you do not need to apply exposure start trigger signals to the camera.

If the **Trigger Mode** parameter is set to **Off**, the camera will automatically begin generating exposure start trigger signals when it receives an **Acquisition Start** command. The camera will continue to generate exposure start trigger signals until it receives an **Acquisition Stop** command.



#### Free-Run

When you set the Trigger Mode parameter to Off, the camera will generate all required trigger signals internally. When the camera is set this way, it will constantly acquire images without any need for triggering by the user. This use case commonly referred as "free run".

---

The rate at which the exposure start trigger signals are generated may be determined by the camera's **Acquisition Frame Rate** parameter.

- If the parameter is set to a value less than the maximum allowed frame rate with the current camera settings, the camera will generate exposure start trigger signals at the rate specified by the parameter setting.
- If the parameter is set to a value greater than the maximum allowed frame rate with the current camera settings, the camera will generate exposure start trigger signals at the maximum allowed frame rate.

### Exposure Time Control with Trigger Mode = Off

When the **Trigger Mode** parameter is set to **Off**, the exposure time for each frame acquisition is determined by the value of the camera's **Exposure Time** parameter. For more information about the Exposure Time parameter, see [8.4 Setting the Exposure Time](#).

### Trigger Mode = On

When the **Trigger Mode** parameter is set to **On**, you must apply an exposure start trigger signal to the camera each time you want to begin a frame acquisition. The **Trigger Source** parameter specifies the source signal that will act as the exposure start trigger signal.

The available settings for the **Trigger Source** parameter are as follows, however, it is recommended to refer to [8.2.4 Applying Trigger Signals](#) for more information on each item:

- **Software**
- **UserOutput0**
- **CC1**
- **Timer0Active**: Refer to [9.20 Timer Control](#) for more information.
- **Line0**: Refer to [7.5 Trigger Input Circuit](#) for more information.

You must also set the **Trigger Activation** parameter after setting the **Trigger Source** parameter. The available settings for the **Trigger Activation** parameter are:

- **Falling Edge**: Specifies that a falling edge of the electrical signal will act as the exposure start trigger.
- **Rising Edge**: Specifies that a rising edge of the electrical signal will act as the exposure start trigger.

### Exposure Time Control with Trigger Mode = On

When the **Trigger Mode** parameter is set to **On** and the **Trigger Source** parameter is set to **Software**, the exposure time for each frame acquisition is determined by the value of the camera's **Exposure Time** parameter.

When the **Trigger Mode** parameter is set to **On** and the **Trigger Source** parameter is set to **CC1** or **Line0**, the exposure time for each frame acquisition will be determined by the **Exposure Mode** parameter settings as follows:

- **Exposure Mode = Timed**: Exposure time can be controlled with the **Exposure Time** parameter.
- **Exposure Mode = TriggerWidth**: Exposure time can be controlled by manipulating the external trigger signal.

When the **Trigger Mode** parameter is set to **On** and the **Trigger Source** parameter is set to **Timer0 Active**, the exposure time for each frame acquisition will be determined by the **Exposure Mode** parameter settings as follows:

- **Exposure Mode = Timed**: Exposure time can be controlled with the **Exposure Time** parameter.
- **Exposure Mode = TriggerWidth**: When you set the **Timer Trigger Activation** parameter to **Rising/Falling Edge**, the exposure time is controlled with the **Timer Duration** parameter. When you set the **Timer Trigger Activation** parameter to **Level High/Low**, the exposure time can be controlled by manipulating the external trigger signal.

When the **Trigger Mode** parameter is set to **On** and the **Trigger Source** parameter is set to **UserOutput0**, the exposure time for each frame acquisition will be determined by the **Exposure Mode** parameter settings as follows:

- **Exposure Mode = Timed**: Exposure time can be controlled with the **Exposure Time** parameter.
- **Exposure Mode = TriggerWidth**: Exposure time can be controlled by switching the **User Output Value** parameter between **On** and **Off**.

### 8.3.2 Using a Software Trigger Signal

If the **Trigger Mode** parameter is set to **On** and the **Trigger Source** parameter is set to **Software**, you must apply a software trigger signal (exposure start) to the camera to begin each frame acquisition. Assuming that the camera is in a **waiting for exposure start trigger** acquisition status, frame exposure will start when the software trigger signal is received by the camera. **Figure 8-2** illustrates frame acquisition with a software trigger signal.

When the camera receives a software trigger signal and begins exposure, it will exit the **waiting for exposure start trigger** acquisition status because at that point, it cannot react to a new exposure start trigger signal. As soon as the camera is capable of reacting to a new exposure start trigger signal, it will automatically return to the **waiting for exposure start trigger** acquisition status.

The exposure time for each acquired frame will be determined by the value of the camera's **Exposure Time** parameter.

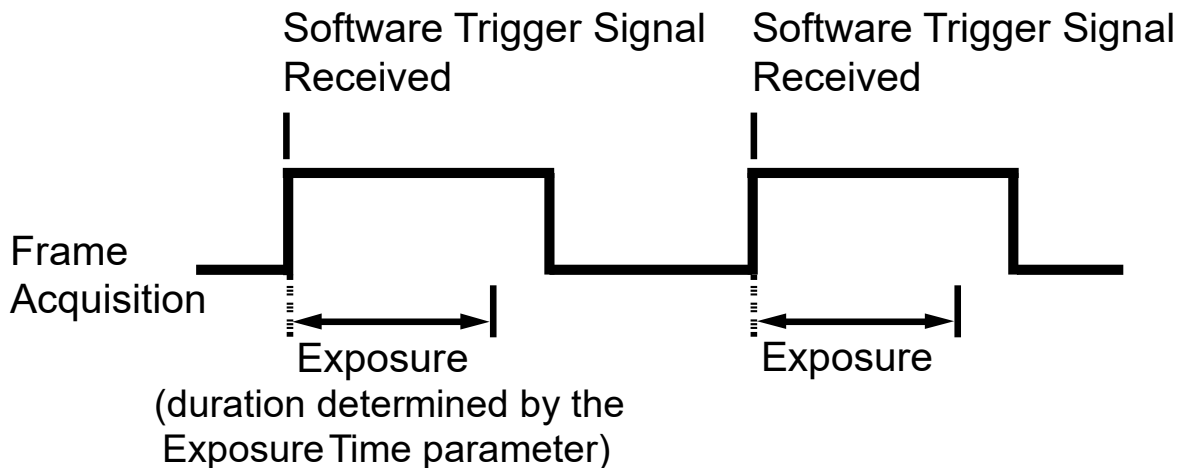

Figure 8-2 Frame Acquisition with Software Trigger Signal

When you are using a software trigger signal to start each frame acquisition, the frame rate will be determined by how often you apply a software trigger signal to the camera, and you should not attempt to trigger frame acquisition at a rate that exceeds the maximum allowed for the current camera settings (There is a detailed explanation about the maximum allowed frame rate at the end of this chapter.). Software trigger signals that are applied to the camera when it is not ready to receive them will be ignored.



### 8.3.3 Using a CC1 Trigger Signal

If the **Trigger Mode** parameter is set to **On** and the **Trigger Source** parameter is set to **CC1**, you must apply a CC1 trigger signal to the camera to begin each frame acquisition. A CC1 trigger signal will act as the exposure start trigger signal for the camera. For more information, refer to your Camera Link frame grabber user manual.

A rising edge or falling edge of the CC1 signal can be used to trigger frame acquisition. The **Trigger Activation** parameter is used to select rising edge or falling edge triggering. Assuming that the camera is in a waiting for exposure start trigger acquisition status, frame acquisition will start whenever the appropriate edge transition is received by the camera.

The camera starts the exposure after receiving a CC1 trigger signal, however, additional new CC1 trigger signal would be ignored while the previous exposure is still in progress. When the camera is operating under control of a CC1 signal, the period of the CC1 trigger signal will determine the rate at which the camera is acquiring lines:

$$\frac{1}{\text{CC1 signal period in seconds}} = \text{Line Rate}$$

For example, if you are operating a camera with a CC1 trigger signal period of 1  $\mu\text{s}$  (0.001 s):  
So in this case, the line rate is 1 kHz.

### 8.3.4 Using an External Trigger Signal

If the **Trigger Mode** parameter is set to **On** and the **Trigger Source** parameter is set to **Line0**, an externally generated electrical signal injected into the Control I/O receptacle will act as the exposure start trigger signal for the camera. This type of trigger signal is generally referred to as a hardware trigger signal.

A rising edge or a falling edge of the external signal can be used to trigger frame acquisition. The **Trigger Activation** parameter is used to select rising edge or falling edge triggering.

Assuming that the camera is in a *waiting for exposure start trigger* acquisition status, frame acquisition will start whenever the appropriate edge transition is received by the camera.

When the camera receives an external trigger signal and begins exposure, it will exit the *waiting for exposure start trigger* acquisition status because at that point, it cannot react to a new exposure start trigger signal.

As soon as the camera is capable of reacting to a new exposure start trigger signal, it will automatically return to the *waiting for exposure start trigger* acquisition status.

When the camera is operating under control of an external signal, the period of the external trigger signal will determine the rate at which the camera is acquiring frames:

$$\frac{1}{\text{External signal period in seconds}} = \text{Frame Rate}$$

For example, if you are operating a camera with an External trigger signal period of 50 ms (0.05 s):

So in this case, the frame rate is 20 fps.

## External Trigger Delay

When you set the **Trigger Source** parameter to **Timer0Active**, you can specify a delay between the receipt of a hardware trigger signal and when the trigger becomes effective.

1. Set the **Timer Trigger Source** parameter in the **Counter And Timer Control** category to **Line0**.
2. Set the **Timer Delay** parameter to the desired Timer delay in microseconds.
3. Set the **Trigger Source** parameter in the **Acquisition Control** category to **Timer0Active**.
4. Execute the **Acquisition Start** command and inject an externally generated electrical signal into the Control I/O receptacle. Then, the delay set by the **Timer Delay** parameter expires and the exposure for image acquisition begins.

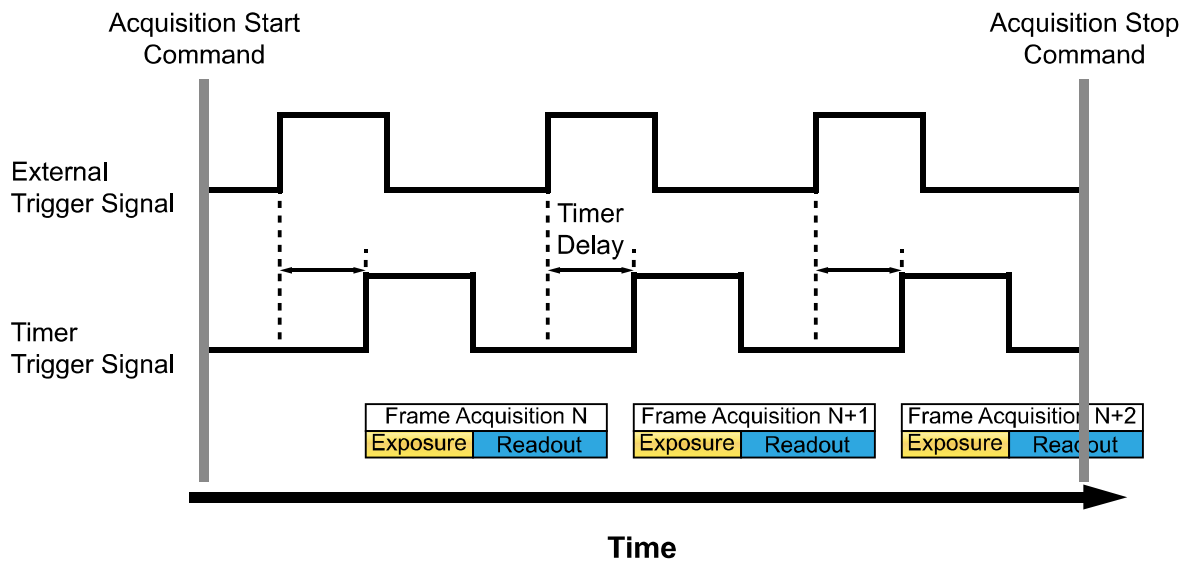

Figure 8-3 External Trigger Delay

### 8.3.5 Exposure Mode

If you are triggering the start of frame acquisition with an externally (CC1 or External) generated trigger signal, two exposure modes are available: **Timed** and **TriggerWidth**.

#### Timed Exposure Mode

When the **Timed** mode is selected, the exposure time for each frame acquisition is determined by the value of the camera's **Exposure Time** parameter. If the camera is set for rising edge triggering, the exposure time starts when the external trigger signal rises. If the camera is set for falling edge triggering, the exposure time starts when the external trigger signal falls. The following figure illustrates **Timed** exposure with the camera set for rising edge triggering.

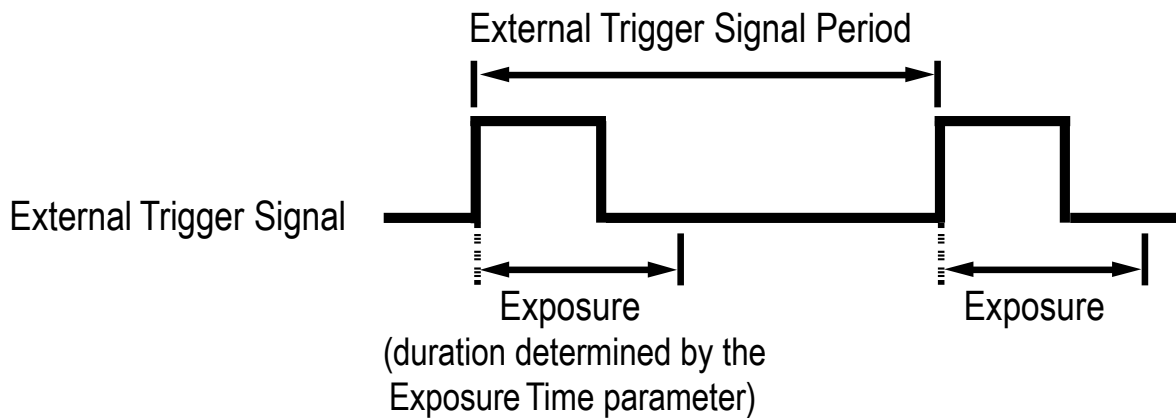

Figure 8-4 Timed Exposure Mode

Note that if you attempt to trigger a new exposure start while the previous exposure is still in progress, the trigger signal will be ignored.

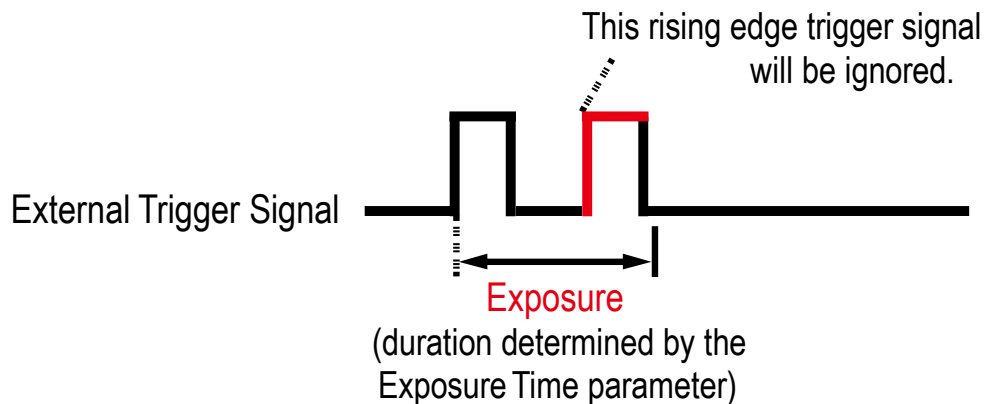

Figure 8-5 Trigger Overlapped with Timed Exposure Mode

### TriggerWidth Exposure Mode

When the **TriggerWidth** exposure mode is selected, the length of the exposure for each frame acquisition will be directly controlled by the external trigger signal (CoaXPress or External). If the camera is set for rising edge triggering, the exposure time begins when the external trigger signal rises and continues until the external trigger signal falls. If the camera is set for falling edge triggering, the exposure time begins when the external trigger signal falls and continues until the external trigger signal rises. The following figure illustrates **TriggerWidth** exposure with the camera set for rising edge triggering.

**TriggerWidth** exposure is especially useful if you intend to vary the length of the exposure time for each frame.

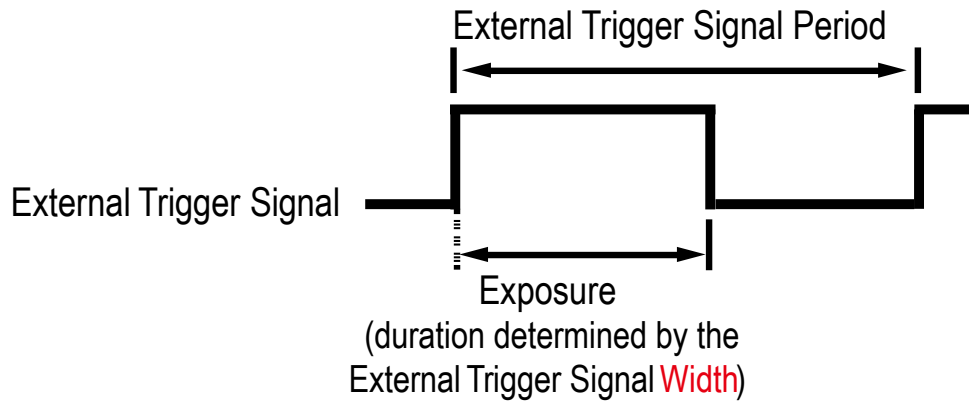

Figure 8-6 **TriggerWidth** Exposure Mode

## 8.4 Setting the Exposure Time

This section describes how the exposure time can be adjusted manually by setting the value of the **Exposure Time** parameter. If you are operating the camera in any one of the following ways, you must specify an exposure time by setting the camera's **Exposure Time** parameter.

- the **Trigger Mode** is set to **Off**.
- the **Trigger Mode** is set to **On** and the **Trigger Source** is set to **CC1** or **Line0**, and the **Exposure Mode** is set to **Timed**.

The **Exposure Time** parameter must not be set below a minimum specified value. The **Exposure Time** parameter sets the exposure time in microseconds ( $\mu\text{s}$ ). The minimum and maximum exposure time settings for the VC-103MC-M/C7I camera are shown in the following table.

Camera Model	Minimum Exposure Time †	Maximum Exposure Time † †
VC-103MC-M/C7I	1 $\mu\text{s}$	60,000,000 $\mu\text{s}$

†: The actual exposure time is determined by adding the **Exposure Time** value in the **Timed** or **TriggerWidth** items to the **Exposure Offset** value of user's choice.

††: When the **Exposure Mode** is set to **TriggerWidth**, the exposure time is controlled by the external trigger signal and has no maximum limit.

Table 8-1 Minimum and Maximum Exposure Time Setting

## 8.5 Overlapping Exposure with Sensor Readout

The frame acquisition process on the camera includes two distinct parts. The first part is the exposure of the pixels in the image sensor. Once exposure is complete, the second part of the process – readout of the pixel values from the sensor – takes place. In regard to this frame acquisition process, the VC-103MC-M/C7I camera basically operates with ‘overlapped’ exposure so that the exposure for a new frame can be overlapped with the sensor readout for the previous frame.

When a new trigger signal is applied to the camera while reading out the previous frame, the camera begins the process of exposing a new frame. This situation is illustrated in the following figure with the **Trigger Mode** set to **On**, the **Trigger Source** set to **Line0** and the **Exposure Mode** set to **TriggerWidth**.

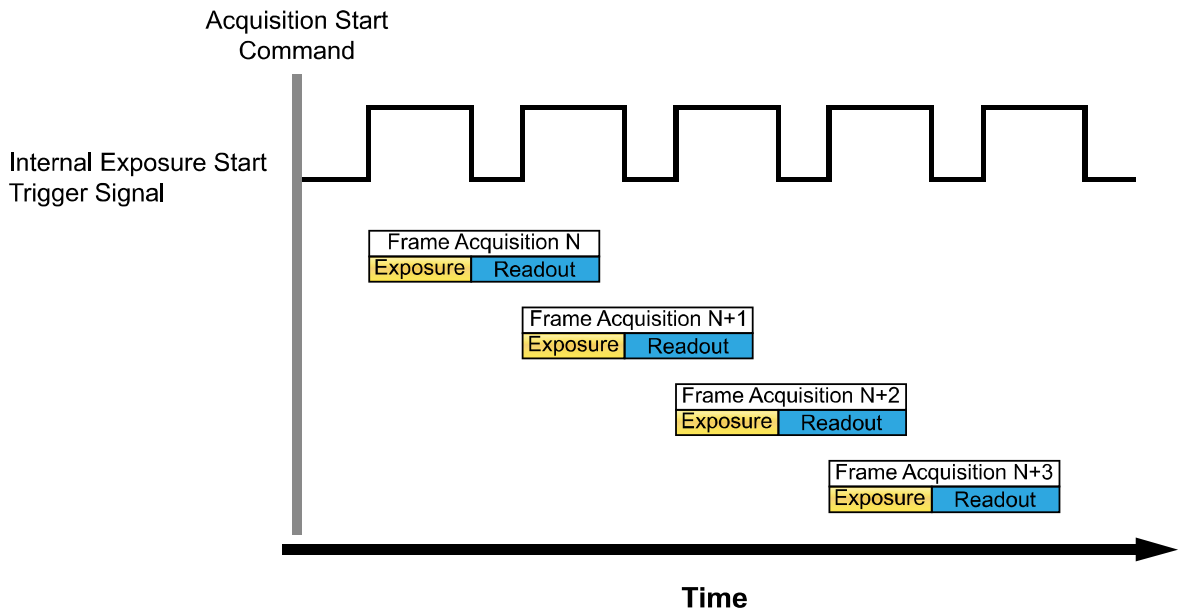

Figure 8-7 Overlapped Exposure and Readout

Determining whether your camera is operating with overlapped exposure and readout is not a matter of issuing a command or changing a setting. Rather a way that you operate the camera will determine whether the exposures and readouts are overlapped or not. If we define the “Frame Period” as the time from the start of exposure for one frame acquisition to the start of exposure for the next frame acquisition, then:

- Overlapped: Frame Period  $\leq$  Exposure Time + Readout Time

### Guidelines for Overlapped Exposure

Since the VC-103MC-M/C7I camera operates with overlapped exposure, you must keep in mind two important guidelines:

- You must not begin the exposure for a new frame while the exposure for the previous frame is in progress.
- You must not end the exposure for the current frame until the readout for the previous frame is complete.

When you are operating the camera with overlapped exposure and using an external trigger signal to trigger image acquisition, you could use the camera's Exposure Time parameter settings and timing formula to calculate when it is safe to begin each new acquisition.



## 8.6 Global Shutter

The VC-103MC-M/C7I camera is equipped with an image sensor that has an electronic global shutter.

When an exposure start trigger signal is applied to the camera equipped with a global shutter, exposure begins for all lines in the sensor as shown in the figure below. Exposure continues for all lines in the sensor until the programmed exposure time ends or when the exposure start trigger signal ends the exposure time if the camera is using the **TriggerWidth** exposure mode. At the end of the exposure time, exposure ends for all lines in the sensor. Immediately after the end of exposure, pixel data readout begins and proceeds line by line until all pixel data is read out of the sensor. A main characteristic of a global shutter is that for each frame acquisition, all of the pixels in the sensor start exposing at the same time and all end exposing at the same time. This means that image brightness tends to be more uniform over the entire area of each acquired image, and it helps to minimize problems with acquiring images of object in motion. The camera can provide an **Exposure Active** output signal that will go high when the exposure time for a frame acquisition begins and will go low when the exposure time ends.

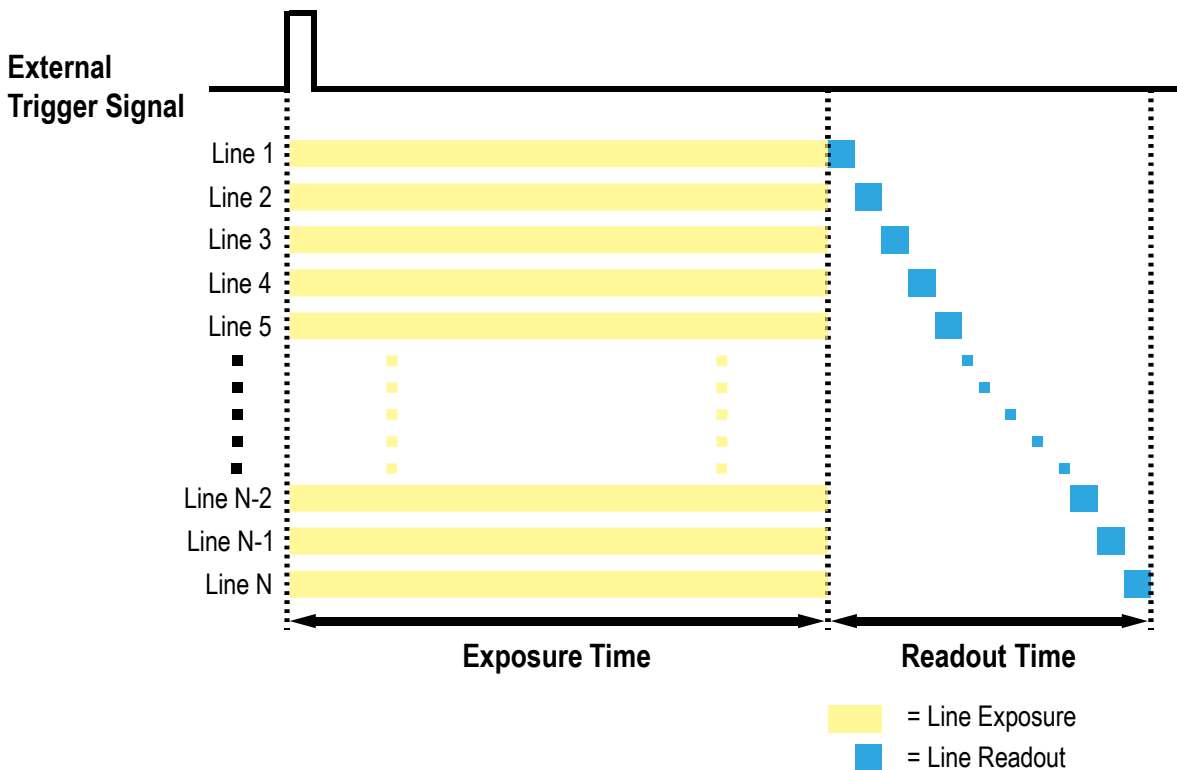

Figure 8-8 Global Shutter

## 8.7 Maximum Allowed Frame Rate

In general, the maximum allowed acquisition frame rate on the camera may be limited by several factors:

- The amount of time that it takes to transmit an acquired frame from the camera to your computer. The amount of time needed to transmit a frame depends on the bandwidth assigned to the camera.
- The amount of time it takes to read an acquired frame out of the image sensor and into the camera's frame buffer. This time varies depending on the setting for ROI. Frames with a smaller height and/or width take less time to read out of the sensor. The frame height and width are determined by the camera's **Height** and **Width** settings in the **Image Format Control** category.
- Camera Link Tap Configuration (Tap Mode) Settings  
When the camera is set for a Tap Mode that uses more taps, it will take less time to transfer acquired images from the camera to the Camera Link frame grabber in your computer. For example, if the camera is set to 8 taps (Camera Link Full Configuration), it can typically transfer data out of the camera two times faster than when the camera is set to 4 taps (Camera Link Medium).
- The exposure time for acquired frames. If you use very long exposure time, you can acquire fewer frames per second.

### 8.7.1 Increasing the Maximum Allowed Frame Rate

You may find that you would like to acquire frames at a rate higher than the maximum allowed with the camera's current settings. In this case, you must adjust one or more of the factors that can influence the maximum allowed frame rate and then check to see if the maximum allowed frame rate has increased.

- The time that it takes to transmit a frame out of the camera is the main limiting factor on the frame rate. You can decrease the frame transmission time (and thus increase the maximum allowed frame rate) by using the ROI feature. Decreasing the size of the Image ROI may increase the maximum allowed frame rate. If possible, decrease the height and/or width of the Image ROI.
- If you are using a Device Tap Geometry with a low number of taps, consider using a Device Tap Geometry with a high number of taps. This will usually increase the maximum allowed frame rate.
- If you are using normal exposure times and you are using the camera at its maximum resolution, your exposure time will not normally restrict the frame rate. However, if you are using long exposure time, it is possible that your exposure time is limiting the maximum allowed frame rate. If you are using a long exposure time, try using a shorter exposure time and see if the maximum allowed frame rate increases (You may need to compensate for a lower exposure time by using a brighter light source or increasing the opening of your lens aperture.).

**Note:**

A very long exposure time severely limits the camera's maximum allowed frame rate. As an example, assume that your camera is set to use a 1 second exposure time. In this case, because each frame acquisition will take at least 1 second to be completed, the camera will only be able to acquire a maximum of one frame per second.

---

## Chapter 9. Camera Features

### 9.1 Sequence of Signal Processing

To acquire the best-quality images, the VC-103MC-M/C7I camera handles signals in the following sequence:

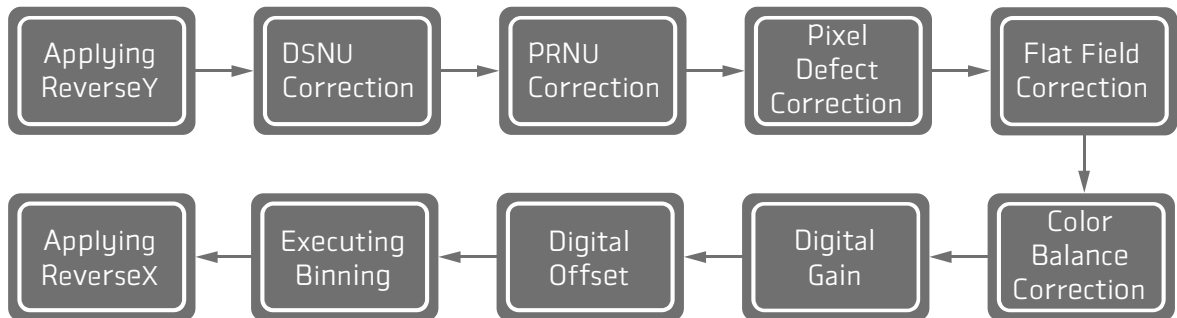

Figure 9-1 Sequence of signal processing to correct images

After finishing the current job, doing all the prior jobs to the current work again is recommended. It may affect the other jobs that have been done before the current job.

## 9.2 Image Region of Interest

The Image Region of Interest (ROI) feature allows you to specify a portion of the sensor array. You can acquire only the frame data from the specified portion of the sensor array while preserving the same quality as you acquire a frame from the entire sensor array.

With the ROI feature, you can increase the maximum allowed frame rate by decreasing the **Height** parameter, however, decreasing the **Width** parameter does not affect the frame rate. The ROI is referenced to the top left corner [origin (0, 0)] of the sensor array as shown below.

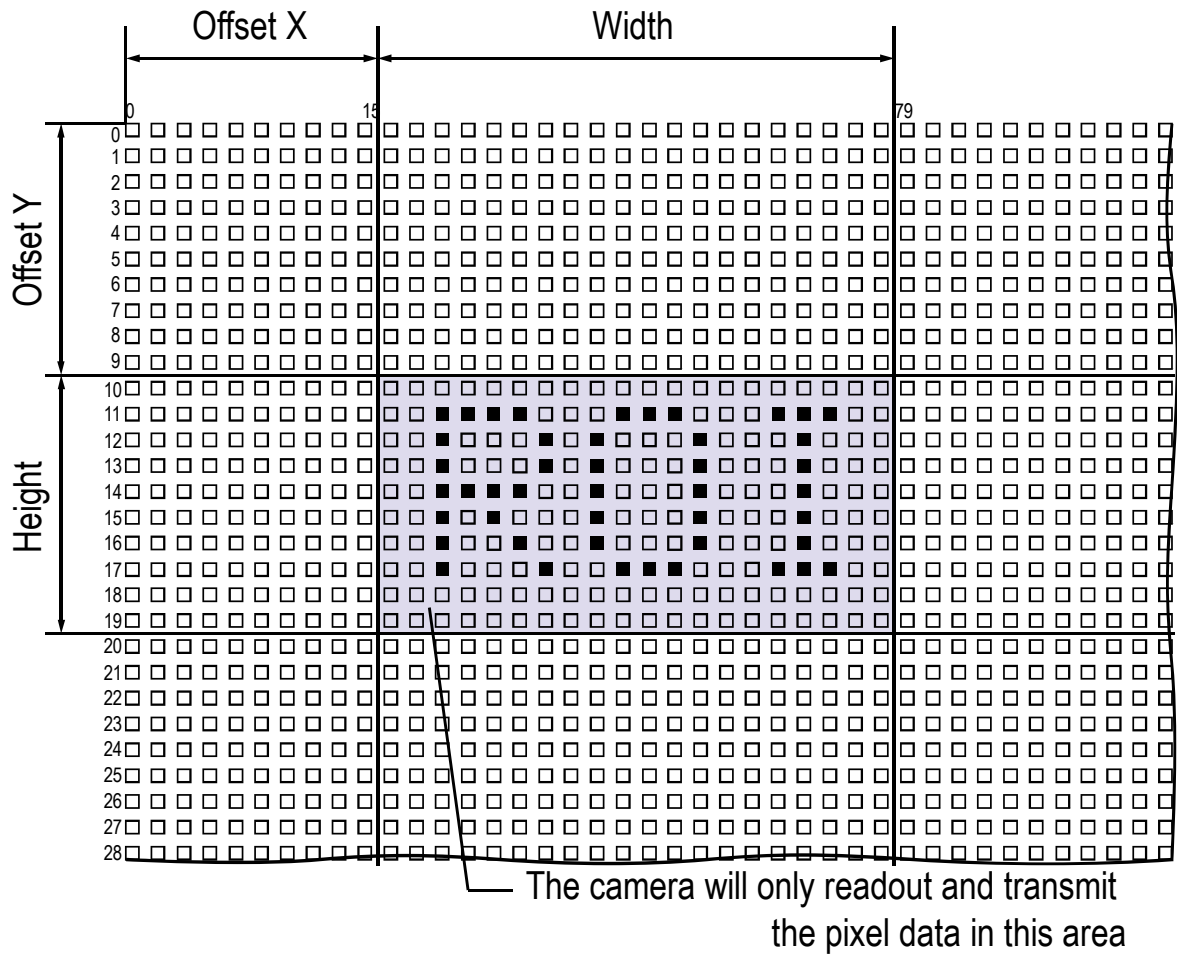

Figure 9-2 Region of Interest

The XML parameters related to ROI settings are as follows.

XML Parameters	Value	Description	
ImageFormatControl	SensorWidth <sup>a</sup>	-	Effective width of the sensor
	SensorHeight <sup>a</sup>	-	Effective height of the sensor
	WidthMax	-	Maximum allowed width of the image with the current camera settings
	HeightMax	-	Maximum allowed height of the image with the current camera settings
	Width <sup>b</sup>	-	Sets the Width of the Image ROI.
	Height <sup>b</sup>	-	Sets the Height of the Image ROI.
	OffsetX <sup>c</sup>	-	Sets the horizontal offset from the origin to the Image ROI.
	OffsetY <sup>c</sup>	-	Sets the vertical offset from the origin to the Image ROI.

The unit for all parameters in this table is pixel.

a: Read only. User cannot change the value.

b: User configurable parameters for setting ROI

c: User configurable parameters for setting the origin of the ROI

Table 9-1 XML Parameters related to ROI

You can change the size of ROI by setting the **Width** and **Height** parameters in the **Image Format Control** category. You can also change the position of the ROI origin by setting the **Offset X** and **Offset Y** parameters. Make sure that the **Width + Offset X** value is less than the **Width Max** value, and the **Height + Offset Y** value is less than the **Height Max** value. You must set the size of the ROI first, and then set the Offset values since the **Width** and **Height** parameters are set to its maximum value by default.

- On the VC-103MC-M/C7I camera, the **Width** parameter must be set to a multiple of 16, and the **Height** parameter must be set to a multiple of 2.

The minimum allowed setting values for the ROI Width and Height are shown below.

Camera Model	Minimum Width Settings	Minimum Height Settings
VC-103MC-M/C7I	16	4

Table 9-2 Minimum ROI Width and Height Settings

On the VC-103MC-M/C7I camera, the maximum allowed frame rates depending on Vertical ROI changes are shown below. The maximum allowed frame rates shown below are based on 8 bit Pixel Format, it may decrease by about 20% in the case of 10 bit.

ROI Size (H × V)	2 Taps	4 Taps	8 Taps	10 Taps
11264 × 4	54.5 fps	104.3 fps	188.7 fps	224.8 fps
11264 × 1000	11.8 fps	23.6 fps	47.1 fps	58.8 fps
11264 × 2000	6.6 fps	13.2 fps	26.4 fps	32.9 fps
11264 × 3000	4.6 fps	9.1 fps	18.3 fps	22.8 fps
11264 × 4000	3.5 fps	7.0 fps	14.0 fps	17.5 fps
11264 × 5000	2.8 fps	5.6 fps	11.3 fps	14.0 fps
11264 × 6000	2.3fps	4.7 fps	9.4 fps	11.7 fps
11264 × 7000	2.0 fps	4.0 fps	8.0 fps	10.0 fps
11264 × 8000	1.7 fps	3.5 fps	7.0 fps	8.8 fps
11264 × 9200	1.5 fps	3.0 fps	6.1 fps	7.6 fps
64 × 9200	24.0 fps	24.0 fps	24.0 fps	24.0 fps
640 × 9200	24.0 fps	24.0 fps	24.0 fps	24.0 fps
1280 × 9200	13.3 fps	24.0 fps	24.0 fps	24.0 fps
2560 × 9200	6.7 fps	13.3 fps	24.0 fps	24.0 fps
3840 × 9200	4.5 fps	8.9 fps	17.7 fps	22.2 fps
5120 × 9200	3.3 fps	6.7 fps	13.3 fps	16.6 fps
6400 × 9200	2.7 fps	5.4 fps	10.7 fps	13.3 fps
7680 × 9200	2.2 fps	4.5 fps	8.9 fps	11.1 fps
8960 × 9200	1.9 fps	3.8 fps	7.6 fps	9.6 fps
10240 × 9200	1.6 fps	3.3 fps	6.7 fps	8.4 fps
11264 × 9200	1.5 fps	3.0 fps	6.1 fps	7.6 fps

Table 9-3 Maximum Frame Rates depending on ROI Changes



**Caution!**

Your Frame Grabber may place additional restrictions on how the ROI location and size must be set. Refer to your Frame Grabber user manual for more information.

### 9.3 Multi-ROI

The VC-103MC-M/C7I camera provides the Multi-ROI feature which allows you to define up to 32 regions of the sensor array. When an image is acquired, only the pixel information from the defined regions will be readout of the sensor. The pixel data read out of the regions will then be combined together and will be transmitted from the camera as a single image.

The XML parameters related to Multi-ROI are as follows.

XML Parameters		Value †	Description
MultiRoiControl	MultiRoiSelector	Region0 - Region31	Selects the ROI to set
	MultiRoiMode	On/Off	Enables/Disables the selected ROI
	MultiRoiWidth	64 - 11264	Width setting for the selected ROI
	MultiRoiHeight	4 - 9200	Height setting for the selected ROI
	MultiRoiOffsetX	0 - 11264	Horizontal offset from the origin to the selected ROI
	MultiRoiOffsetY	0 - 9200	Vertical offset from the origin to the selected ROI
	MultiRoiValid <sup>a</sup>	-	Verifies the validation of the Multi-ROI setting values
	MultiRoiStatus	Active/Inactive	Displays the status of the Multi ROI feature Active: The Multi-ROI feature is in use Inactive: The Multi-ROI feature is not in use

†: The unit for all parameters in this table is pixel.

a: If the setting values for the Multi-ROI feature are valid, 'True' will be returned or the check box will be selected.

Table 9-4 XML parameters related to Multi-ROI

It is recommended that you first set the **MultiRoiWidth** parameter, since all of the regions must be the same width. The next step in the setup process is to define each individual region as desired. Up to 32 regions can be set up ranging from 0 through 31. Use the **MultiRoiSelector** parameter to select which ROI to set and then set the ROI to On/Off by using the **MultiRoiMode** parameter. Then, set the **MultiRoiOffsetX**, **MultiRoiOffsetY** and **MultiRoiHeight** parameters to define each region.



In the figure below, for example, three regions have been set. With these settings, the camera would output an image as follows:

- MultiROI Width × the total height of the three regions (Region0 Height + Region1 Height + Region2 Height)

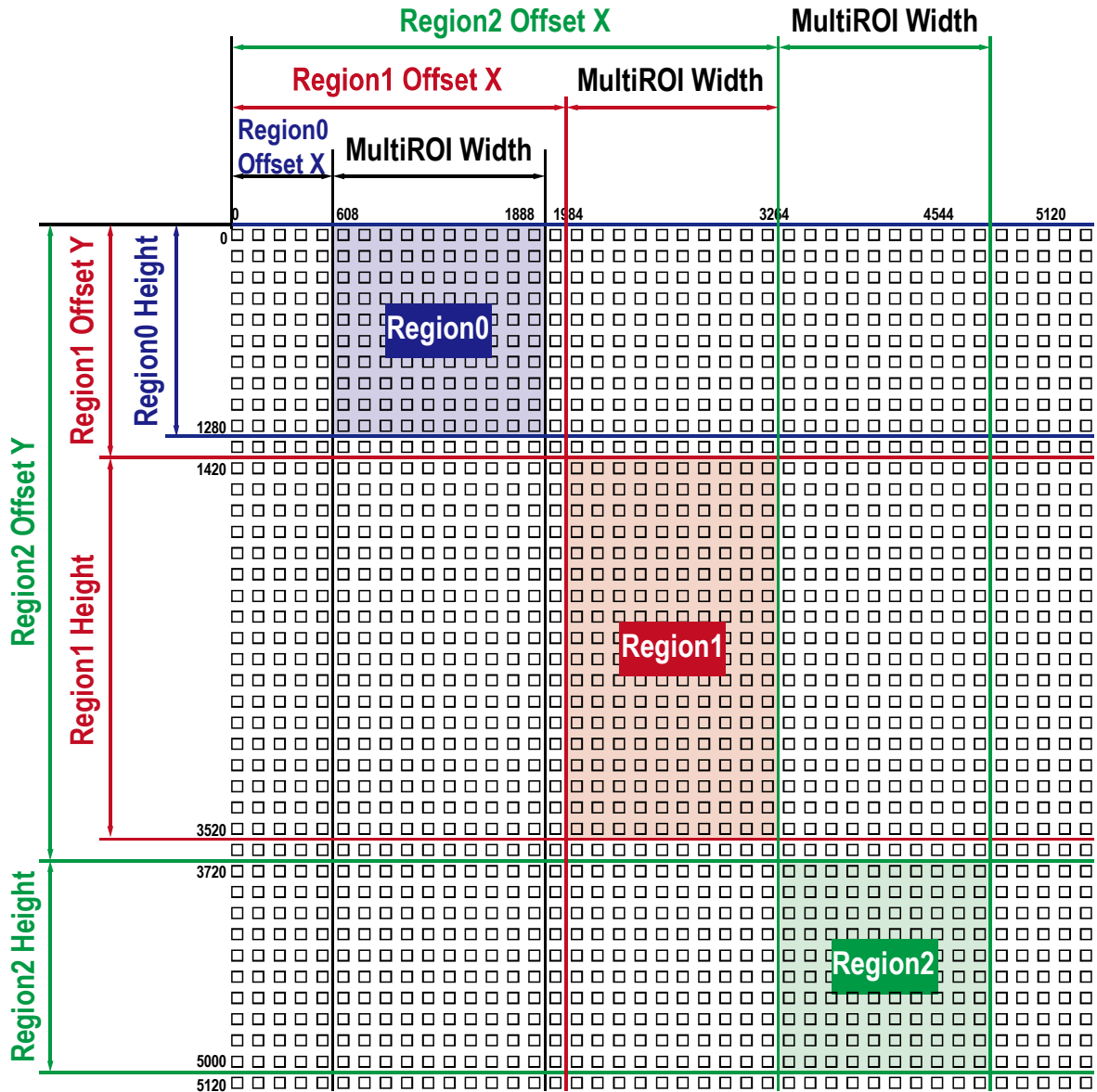

Figure 9-3 Multi-ROI

There are several things to keep in mind when setting the Multi-ROI feature on the VC-103MC-M/C7I camera:

- The sum of the MultiRoiOffsetX value plus the MultiRoiWidth value must not exceed the Width value of the camera's sensor.
- The sum of the MultiRoiOffsetY value plus the MultiRoiHeight value must not exceed the Height value of the camera's sensor.
- The MultiRoiOffsetX and MultiRoiWidth value must be a multiple of 8.
- The MultiRoiOffsetY and MultiRoiHeight value must be a multiple of 2.
- The MultiRoiWidth values are equal, so the widths of the Region 0, Region 1, and Region 2 are the same in the figure above.
- You can save the Multi-ROI setting values as a User Set and then load the values to the camera when desired. For more information, refer to [9.31 User Set Control](#).

## 9.4 Binning

The Binning has the effects of increasing the level value and decreasing resolution by summing the values of the adjacent pixels and sending them as one pixel.

The XML parameters related to Binning are as follows.

XML Parameters		Value	Description
ImageFormat Control	BinningSelector	Sensor	N/A
		Logic	Applies the Binning in digital by the logic.
	Binning HorizontalMode	Sum	Adds pixel values from the adjacent pixels as specified in the Binning Horizontal, and then sends them as one pixel.
		Average	Adds pixel values from the adjacent pixels as specified in the Binning Horizontal and divides them by the number of combined pixels, and then sends them as one pixel.
	BinningHorizontal	1×, 2×, 4×	The number of horizontal pixels to combine together. 4× is supported only for monochrome.
	Binning VerticalMode	Sum	Adds pixel values from the adjacent pixels as specified in the Binning Vertical, and then sends them as one pixel.
		Average	Adds pixel values from the adjacent pixels as specified in the Binning Vertical and divides them by the number of combined pixels, and then sends them as one pixel.
	BinningVertical	1×, 2×, 4×	The number of vertical pixels to combine together. 4× is supported only for monochrome.

Table 9-5 XML Parameters related to Binning

For example, if you set  $2 \times 2$  binning, the camera's resolution is reduced to  $1/4$ . If you set the **Binning Mode** to **Sum**, the maximum allowed settings for both the horizontal and vertical resolution of the camera are reduced to  $1/2$  and the responsivity of the camera is quadrupled. If you set the **Binning Mode** to **Average**, the maximum allowed settings for both the horizontal and vertical resolution of the camera are reduced to  $1/2$ , but there is no difference in responsivity between a binned image and an original image. The **Width Max** and **Height Max** parameters, indicating the maximum allowed resolution of the image with the current camera settings, will be updated depending on the binning settings. The **Width**, **Height**, **Offset X** and **Offset Y** parameters also will be updated depending on the binning settings. You can verify the current resolution through the **Width** and **Height** parameters.

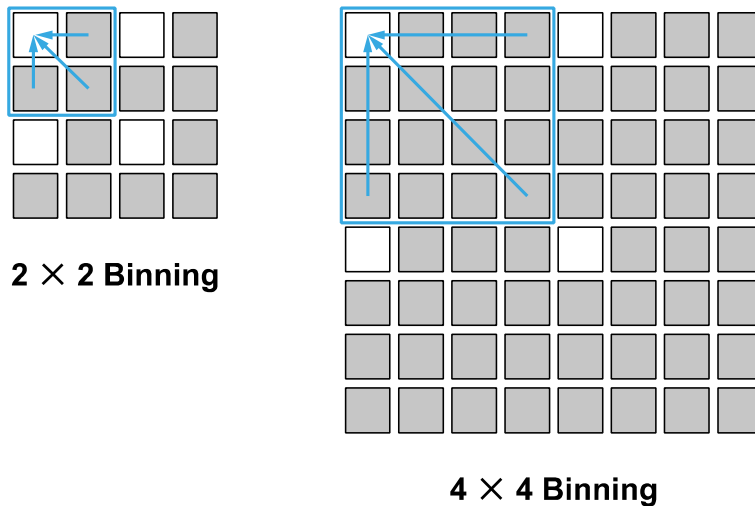

Figure 9-4  $2 \times 2$  Binning and  $4 \times 4$  Binning

## 9.5 Camera Link Clock

The VC-103MC-M/C7I camera provides selectable Camera Link Pixel Clock speeds. The Pixel Clock speed determines that the rate at which pixel data will be transmitted from the camera to the frame grabber in your computer via the Camera Link interface. Setting the camera for a higher Pixel Clock speed will increase the rate at which image data is transferred from the camera to the frame grabber. Before setting the camera's Pixel Clock speed, make sure you determine the maximum Pixel Clock speed supported by your frame grabber. Then, you should not attempt to set the camera's Pixel Clock speed that exceeds the maximum Pixel Clock speed for your frame grabber.

The XML parameters related to Camera Link Pixel Clock speed is as follows.

XML Parameters		Value	Description
CameraLink	CameraLinkClock	Clock0	Sets the Camera Link Clock speed to 85 Mhz.
		Clock1	Sets the Camera Link Clock speed to 65 Mhz.
	CameraLinkClockFrequency	-	Displays the current Camera Link Clock speed in Mhz.

Table 9-6 XML Parameters related to Camera Link Clock Speed

## 9.6 Device Tap Geometry

The VC-103MC-M/C7I camera supports 2 Taps, 4 Taps, 8 Taps and 10 Taps Device Tap Geometry. The number of taps represents the number of pixel data that will be output on each cycle of the Camera Link Pixel Clock. The maximum allowed frame rate will be changed according to the Device Tap Geometry settings. The image data is transmitted in the interleaved order as shown in the figure below.

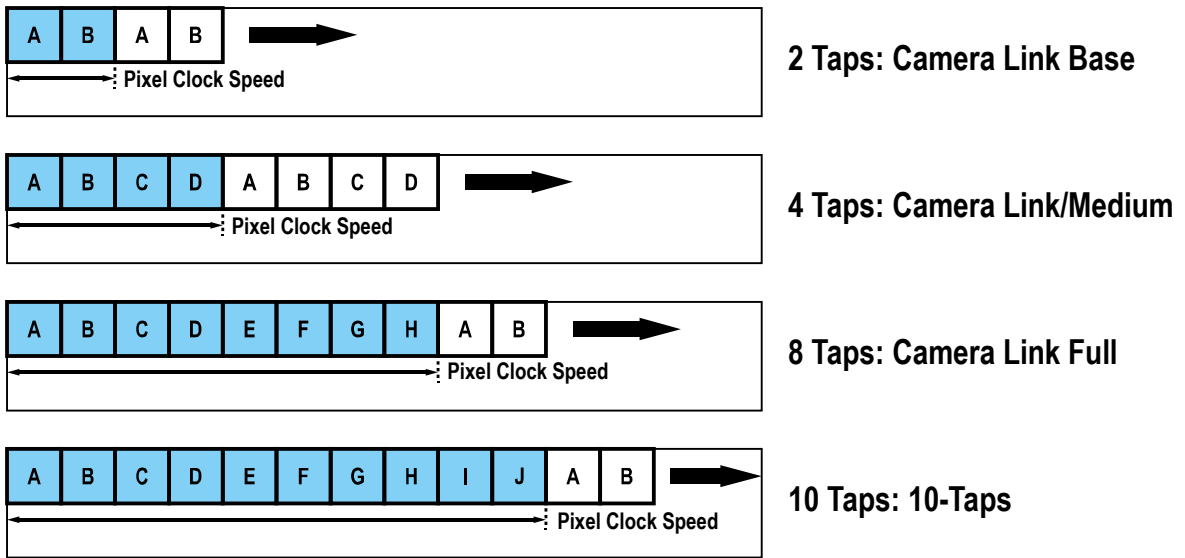

Figure 9-5 Device Tap Geometry

The XML parameter related to Device Tap Geometry is as follows.

XML Parameters		Value	Description
TransportLayer Control	DeviceTap Geometry	Geometry_1X2_1Y	Sets the Device Tap Geometry to 2 Taps
		Geometry_1X4_1Y	Sets the Device Tap Geometry to 4 Taps
		Geometry_1X8_1Y	Sets the Device Tap Geometry to 8 Taps
		Geometry_1X10_1Y	Sets the Device Tap Geometry to 10 Taps

Table 9-7 XML Parameter related to Device Tap Geometry

### 9.7 Pixel Format

The VC-103MC-M/C7I camera processes image data in the unit of 12 bit. The pixel format of the image data is available to be chosen among 8 bit, 10 bit, or 12 bit with the **Pixel Format** parameter. For instance, the 2 least significant bits will be dropped from overall 10 bits when the camera is set for 10-bit pixel format.

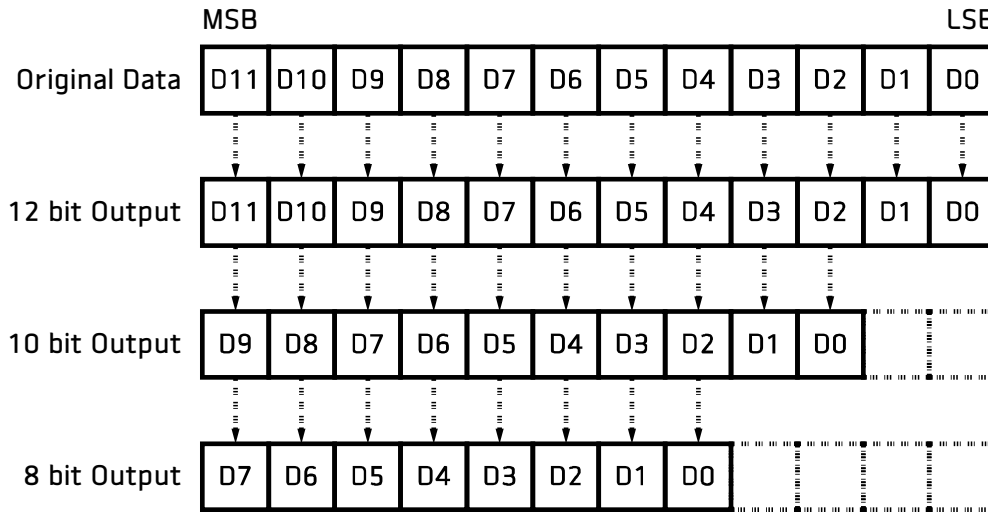

Figure 9-6 VC-103MC-M/C7I' Pixel Format

The XML parameter related to Pixel Format is as follows.

XML Parameter	Description
ImageFormatControl PixelFormat	Sets the pixel format supported by the device

Table 9-8 XML Parameter related to Pixel Format

The available pixel formats on the monochrome and color cameras are as follows.

Mono Sensor	Color Sensor
Mono 8	Mono 8
Mono 10	Mono 10
Mono 12	Mono 12
	Bayer GB 8
	Bayer GB 10
	Bayer GB 12

Table 9-9 Pixel Format Values

### 9.8 Data ROI (Color Only)

The Balance White Auto feature provided by the color camera uses the pixel data from a Data Region of Interest (ROI) to adjust the related parameters. The XML parameters related to Data ROI are as follows.

XML Parameters		Value	Description
DataRoiControl	RoiSelector	WhiteBalanceAuto	Selects a Data ROI used for Balance White Auto. Only available on the color camera
	RoiOffsetX	-	X coordinate of start point ROI
	RoiOffsetY	-	Y coordinate of start point ROI
	RoiWidth	16 - 11264	Width of ROI
	RoiHeight	2 - 9200	Height of ROI

Table 9-10 XML Parameters related to Data ROI

Only the pixel data from the area of overlap between the Data ROI and the Image ROI by your settings will be effective if you use the Image ROI and Data ROI at the same time. The effective ROI is determined as shown in the figure below.

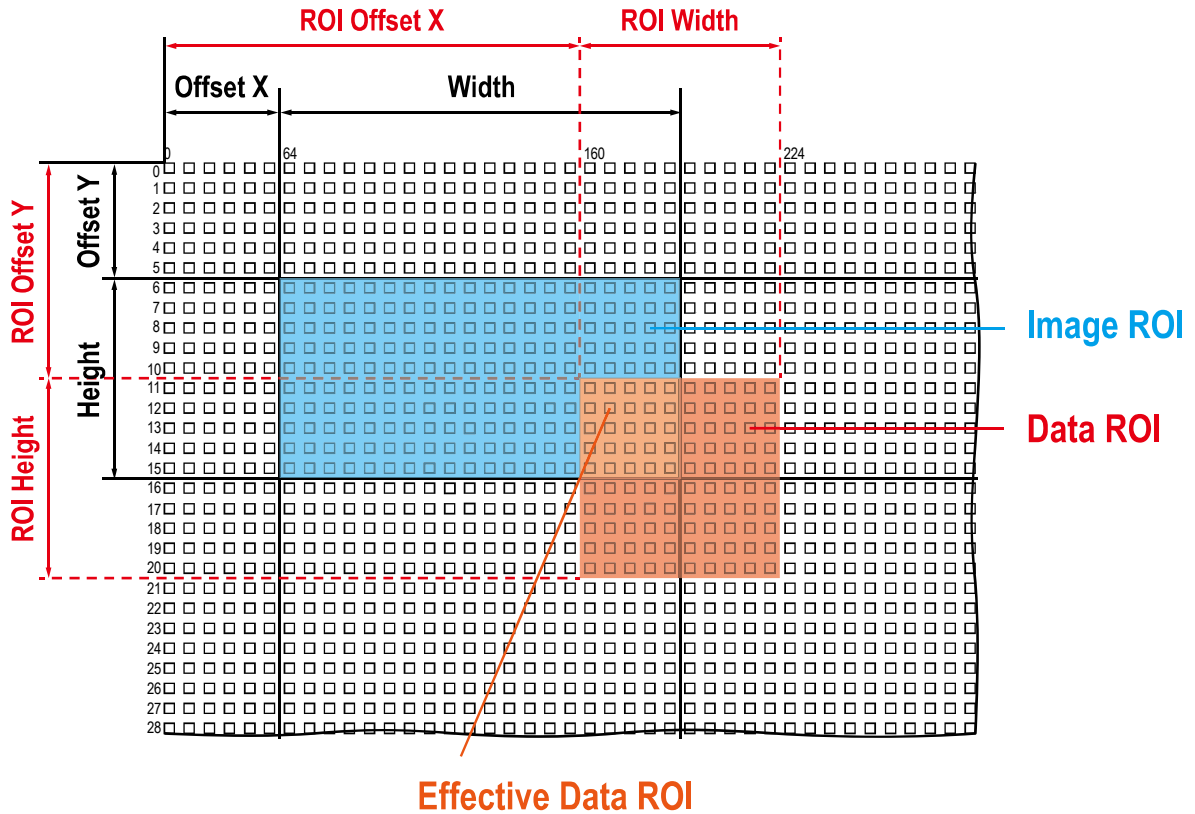

Figure 9-7 Effective Data ROI



## 9.9 White Balance (Color Only)

The color camera includes the white balance capability to adjust the color balance of the images transmitted from the camera. With the white balancing scheme used on the VC-103MC-M/C7I camera, the Red, Green, and Blue intensities can be adjusted individually. You can set the intensity of each color by using the **Balance Ratio** parameter. The Balance Ratio value can range from 1.0 to 4.0. If the **Balance Ratio** parameter is set to 1.0 for a color, the intensity of the color will be unaffected by the white balance mechanism. If the **Balance Ratio** parameter is set to greater than 1.0, the intensity of the color will be proportionally increased to the ratio. For example, if the **Balance Ratio** is set to 1.5, the intensity of that color will be increased by 50%.

The XML parameters related to White Balance are as follows.

XML Parameters		Value	Description
AnalogControl	BalanceRatio Selector	Red	A Balance Ratio value will be applied to red pixels.
		Green	A Balance Ratio value will be applied to green pixels.
		Blue	A Balance Ratio value will be applied to blue pixels.
	BalanceRatio	×1.0 ~ ×4.0	Adjusts the ratio of the selected color.

Table 9-11 XML Parameters related to White Balance

### 9.9.1 Balance White Auto

The Balance White Auto feature is implemented on the color camera. It will control the white balance of the image acquired from the color camera according to the GreyWorld algorithm. Before using the Balance White Auto feature, you need to set the Data ROI for Balance White Auto. If you do not set the related Data ROI, the pixel data from the Image ROI will be used to control the white balance. As soon as the **Balance White Auto** parameter is set to **Once**, the Balance Ratio values for Red and Blue will be automatically adjusted to adjust the white balance by referring to Green.

The XML parameters related to Balance White Auto are as follows.

XML Parameter		Value	Description
AnalogControl	BalanceWhite Auto	Off	Balance White Auto Off
		Once	White Balance is adjusted once and then Off.

Table 9-12 XML Parameter related to Balance White Auto

## 9.10 Gain

Increasing the **Gain** parameter increases all pixel values of the image. This results in a higher grey value output from the camera for a given amount of output from the image sensor.

1. Selects the Gain Control (**Analog All**, **Digital All**) to be adjusted by using the **Gain Selector** parameter.
2. Sets the **Gain** parameter to the desired value.

The XML parameters related to Gain are as follows.

XML Parameters		Value	Description
Analog Control	GainSelector	Analog All	Applies the Gain value to all analog channels.
		Digital All	Applies the Gain value to all digital channels.
Gain		1.4x – 5.2x	Sets an analog gain value.
		1.0x – 32.0x	Sets a digital gain value.

Table 9-13 XML Parameters related to Gain

## 9.11 Black Level and Optical Black Correction

The VC-103MC-M/C7I camera offers the Optical Black Correction feature that adjusts the Black Level value into 0 automatically depending on a sensor. With this feature, good levels of images are easy to be acquired regardless of sensor-specific factors, because the feature makes the sensor optimize the Black Level automatically.

To make a sensor optimize Black Level automatically to fit into the value 0, use the feature by activating the checkbox of the **OpticalBlackCorrection** parameter.

However, Black Level needs to be adjusted manually by a user in the following cases:

- Very bright environment
- Very long exposure time

In the cases above, adjusting the **BlackLevelOffset** parameter will result in an offset to the pixel values output from the camera. To adjust Black Level manually, use the following procedure:

1. First, configure the environment as follows:
  - No light the surroundings by blocking light
  - Darken a sensor by capping its camera with a plastic cap
  - Close an iris to the maximum
2. Deactivate the checkbox of the **OpticalBlackCorrection** parameter.
3. Choose **DigitalAll** on the **BlackLevelSelector** parameter.
4. Set the **BlackLevelOffset** value to the value of your wish by adjusting its slider bar.

To apply a positive number(from 0 to 64) to the **BlackLevelOffset** value, it is recommended to check if the **OpticalBlackCorrection** checkbox is deactivated. In case that the checkbox has been activated, inactivate the checkbox first, after that, control the **BlackLevelOffset** value.

5. Before set the **BlackLevel** value, refer to the sequence described in **Figure 9-8** below and finish the other necessary jobs related to acquired images.
6. Set the **BlackLevel** parameter as the necessary value. The range of the value varies with sensors or setting values of the **Pixel Format** parameters.

The figure below shows sequence of the signal processing related to Black Level, and the "Digital Offset" item indicates those related to Black Level. It is recommended to do the prior jobs such as DSNU or PRNU corrections, after then, to do the job related to Black Level.

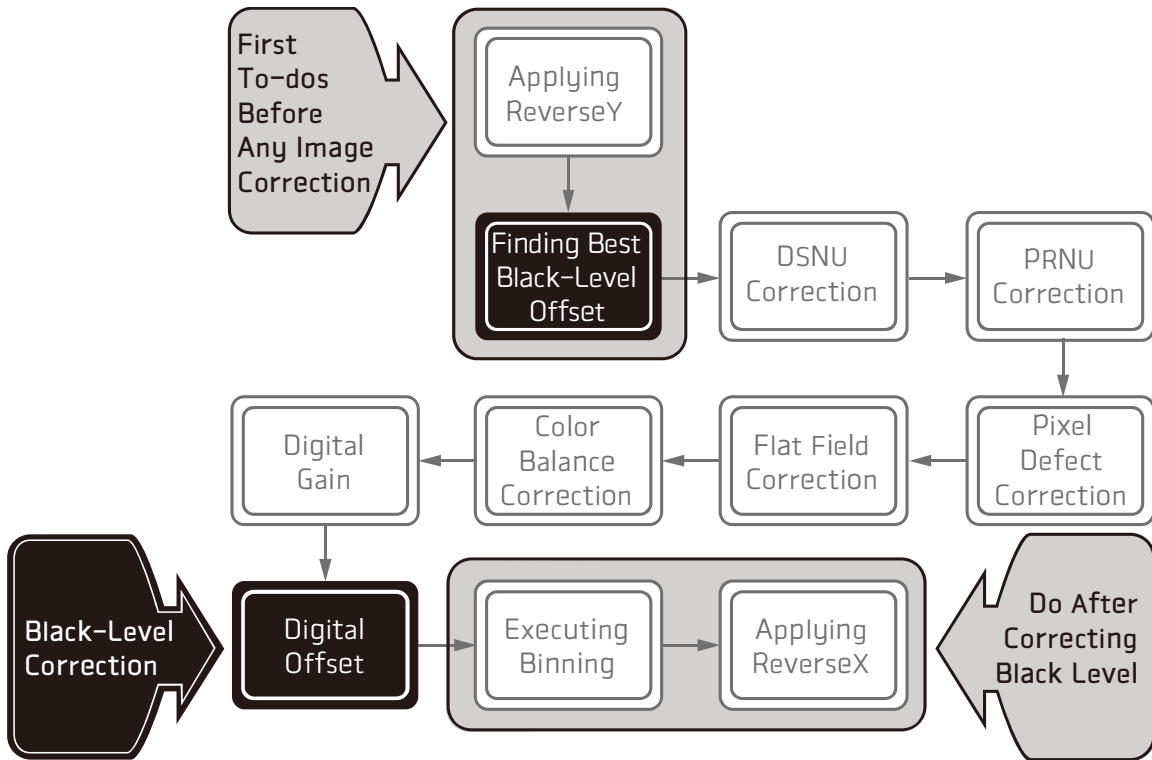

Figure 9-8 Sequence of signal processing and Black Level



**System's sequence of the signal processing:**

The product handles signals basically in the sequence described in Figure 9-8 above. For instance, no need to work again if you did the DSNU/PRNU correction or others prior to the Black Level job, however, it needs to be done again in the case that it was finished before the DSNU/PRUN correction or others.

The XML parameters related to Black Level are as follows.

XML Parameters		Value	Description
ImageFormat Control	OpticalBlack Correction	False	Changes into the mode available to adjust manually by a user.
		True	Changes into the mode available to optimize automatically by a sensor.
Analog Control	BlackLevelSelector	DigitalAll	Applies the Black Level value to all digital channels.
	BlackLevel	8 bit: 0 ~ 15.93 10 bit: 0 ~ 63.75 12 bit: 0 ~ 255.00	Sets a black level value.
	BlackLevelOffset	-64 ~ 64	Sets a value of Black Level manually.

Table 9-14 XML Parameters related to Black Level



#### Manual setting of the BlackLevelOffset value:

To adjust Black Level precisely and manually, first, deactivate the **OpticalBlackCorrection** feature and then input the **BlackLevelOffset** value. The value will not work although the value of the parameter is adjusted under the **OptimicalBlackCorrection** feature has been activated.

## 9.12 Defective Pixel Correction

The CMOS sensor may have defect pixels which cannot properly react to the light. Correction is required since it may deteriorate the quality of output image. Defect pixel information of CMOS used for each camera is entered into the camera during the manufacturing process. If you want to add defect pixel information, it is required to enter coordinate of new defect pixel into the camera. For more information, refer to [Appendix A](#).

The XML parameters related to the Defective Pixel Correction feature are as follows.

Command	Value	Description
Defective Pixel Correction	FALSE	Disables the Defective Pixel Correction feature.
	TRUE	Enables the Defective Pixel Correction feature.

Table 9-15 Commands related to Dynamic Defective Pixel Correction

### Correction Method

A correction value for a defect pixel is calculated based on the valid pixel value adjacent in the same line.

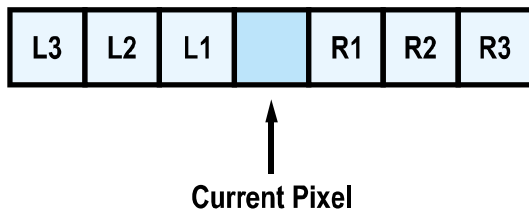

Figure 9-9 Location of Defect Pixel to be corrected

If the Current Pixel is a defect pixel as shown in the figure above, the correction value for this pixel is obtained as shown in the following table depending on whether surrounding pixels are defect pixels or not.

Adjacent Defect Pixel	Correction Value of Current Pixel
None	$(L1 + R1) / 2$
L1	R1
R1	L1
L1, R1	$(L2 + R2) / 2$
L1, R1, R2	L2
L2, L1, R1	R2
L2, L1, R1, R2	$(L3 + R3) / 2$
L2, L1, R1, R2, R3	L3
L3, L2, L1, R1, R2	R3

Table 9-16 Calculation of Defect Pixel Correction Value

### 9.13 Dark Signal Non-uniformity Correction

In theory, when a digital camera acquires images in complete darkness, all of the pixel values in the image should be near zero and they should be equal. In practice, however, slight variations in the performance of the pixels in the sensor will cause some variations in the pixel values output from the camera when the camera is acquiring in darkness. This variation is known as Dark Signal Non-uniformity (DSNU). The VC-103MC-M/C7I cameras provide the DSNU Correction feature.

The XML parameters related to DSNU are as follows.

XML Parameters	Value	Description	
DSNU	DSNUDataSelector	Default	Selects Default as a non-volatile memory location to load DSNU data from.
		Space1 - 3	Selects a user defined location as a non-volatile memory location to save DSNU data to or load DSNU data from.
	DSNUDataGenerate	-	Generates the DSNU data for the current camera settings.
	DSNUDataSave	-	Saves the generated DSNU data in the non-volatile memory. The generated data by executing the DSNUDataGenerate command are saved in the volatile memory so that the data are lost if the camera is reset or if power is turned off. To use the data after the camera is powered on or reset, save them in the non-volatile memory.
	DSNUDataLoad	-	Loads the DSNU data from the non-volatile memory into the volatile memory.

Table 9-17 XML Parameters related to DSNU

### 9.13.1 Generating and Saving User DSNU Correction Values

To generate and save user DSNU correction values, use the following procedure.



**Note:**

- For optimum DSNU correction results, we recommend that you generate DSNU data after the temperature of the camera housing has been stabilized.
- Before generating DSNU data, set the FFC feature to Off.
- Before executing the DSNU correction, you must set the camera as follows:  
OffsetX, OffsetY: 0  
Width, Height: Maximum values

1. Ensure that the camera will be acquiring images in complete darkness by covering the camera lens, closing the iris in the lens, or darkening the room.
2. Begin acquiring images by setting the camera for the Free-Run mode.
3. Execute the **DSNU Data Generate** command to generate DSNU data for the current camera settings.
4. The generated DSNU correction values will be activated and saved in the camera's volatile memory.
5. To save the generated DSNU correction values in the camera's Flash (non-volatile) memory, use the **DSNU Data Selector** parameter to specify a location to save the DSNU correction values, and then execute the **DSNU Data Save** command. The previous DSNU values saved in the memory will be overwritten.

To disregard the generated DSNU correction values and load the existing values in the Flash memory, use the **DSNU Data Selector** parameter to select a desired DSNU correction values, and then execute the **DSNU Data Load** command.



## 9.14 Photo Response Non-uniformity Correction

In theory, when a line scan camera acquires images with the camera viewing a uniform light-colored target in bright light, all of the pixel values in the image should be near the maximum grey value and they should be equal. In practice, however, slight variations in the performance of the pixels in the sensor, variations in the optics, and variations in the lighting will cause some variations in the pixel values output from the camera. This variation is known as Photo Response Non-uniformity (PRNU). The VC-103MC-M/C7I camera provides the PRNU Correction feature.

The XML parameters related to PRNU are as follows.

XML Parameters	Value	Description
PRNU PRNUNUDataSelector	Default	Selects Default as a non-volatile memory location to load PRNU data from.
	Space1 - 3	Selects a user defined location as a non-volatile memory location to save PRNU data to or load PRNU data from.
PRNUDataGenerate	-	Generates the PRNU data for the current camera settings.
PRNUDataSave	-	Saves the generated PRNU data in the non-volatile memory. The generated data by executing the <b>PRNUDataGenerate</b> command are saved in the volatile memory so that the data are lost if the camera is reset or if power is turned off. To use the data after the camera is powered on or reset, save them in the non-volatile memory.
PRNUDataLoad	-	Loads the PRNU data from the non-volatile memory into the volatile memory.

Table 9-18 XML Parameters related to PRNU

### 9.14.1 Generating and Saving User PRNU Correction Values

To generate and save user-defined PRNU correction values, use the following procedures.

**Note:**

To generate the optimum PRNU data;

- we recommend that you generate DSNU correction values first before generating PRNU correction values.
- set the FFC feature to Off before generating PRNU correction values.
- before executing the DSNU correction, you must set the camera as follows:
  - OffsetX, OffsetY: 0
  - Width, Height: Maximum values
- the grey reference image must be acquired at uniform illumination. We strongly recommend that you use a high quality light source to deliver uniform illumination. Standard illumination may not be appropriate.

The PRNU correction values stored in Default are optimized for use in typical situations and will provide good camera performance in most cases. Use of the values stored in Default is recommended.

1. To generate PRNU correction values suitable for your operating conditions, use the same as the illumination in the actual environment. We strongly recommend that you use the Default PRNU correction values stored in Default, if you cannot set up the uniform illumination.
2. Without mounting a lens on the camera, place a uniform illumination (e.g. backlight) in the field of view of the camera. Set up the camera as you would for normal operation. We recommend that you make adjustments to achieve the digital output level in a range from 150 to 200 (Gain: 1.00 at 8 bit).
3. Begin acquiring images by setting the camera for the Free-Run mode.
4. Execute the **PRNU Data Generate** command to generate PRNU correction values for the current camera settings.
5. The generated PRNU correction values will be activated and saved in the camera's volatile memory.
6. To save the generated PRNU correction values in the camera's Flash (non-volatile) memory, use the **PRNU Data Selector** parameter to specify a location to save the PRNU correction values, and then execute the **PRNU Data Save** command. The previous PRNU values saved in the memory will be overwritten.

To disregard the generated PRNU correction values and load the existing values in the Flash memory, use the **PRNU Data Selector** parameter to select a desired PRNU correction values, and then execute the **PRNU Data Load** command.

## 9.15 Flat Field Correction

The Flat Field Correction feature improves the image uniformity when you acquire a non-uniformity image due to external conditions. The Flat Field Correction feature of the VC-103MC-M/C7I camera can be summarized by the following equation.

$$IC = IR / IF$$

IC: Level value of corrected image

IR: Level value of original image

IF: Level value of Flat Field data

In actual use conditions, generate a Flat Field correction data and then save the data into the non-volatile memory of the camera by following the procedures below.

1. Execute the **Flat Field Data Generate** parameter.

After executing the **Flat Field Data Generate** parameter, you must acquire one image to generate the scaled down Flat Field correction data.

2. Use the **Flat Field Data Selector** parameter to specify a location to save the generated Flat Field correction data.
3. Execute the **Flat Field Data Save** parameter to save the generated Flat Field data into the non-volatile memory. When the scaled down Flat Field data are used for correction, they are expanded and applied with a Bilinear Interpolation as shown in the **Figure 9-11**.

To disregard the generated Flat Field correction data and load the existing Flat Field correction data, execute the **Flat Field Data Load** parameter before executing the **Flat Field Data Save** parameter.

4. Set the **Flat Field Correction** parameter to **On** to apply the Flat Field data to the camera.



### Caution!

- It is recommended that you enable the Defective Pixel Correction feature before executing the Flat Field Data Generate parameter.
- Before executing the Flat Field Data Generate parameter, you must set the camera as follows:  
OffsetX, Y: 0  
Width, Height: Maximum values
- After executing the Acquisition Start command, you need to operate the camera with the free-run mode or apply a trigger signal to acquire an image.

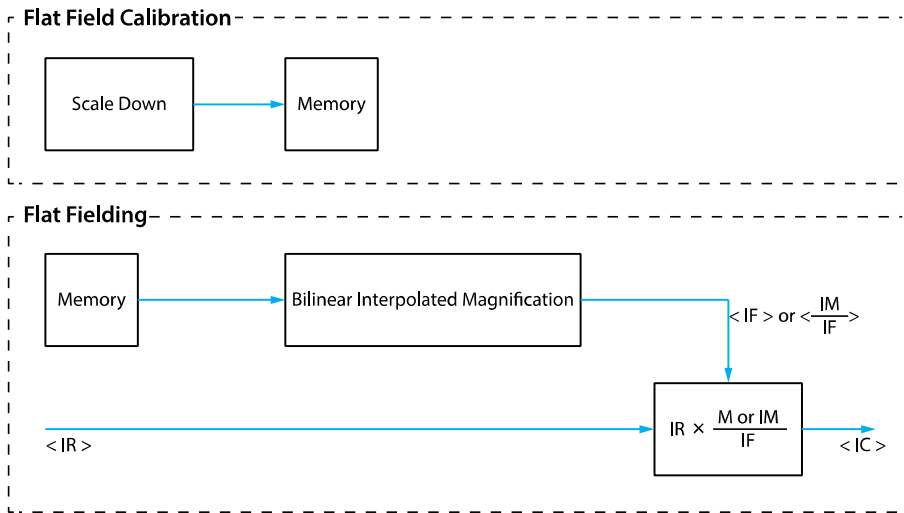

Figure 9-10 Generation and Application of Flat Field Data

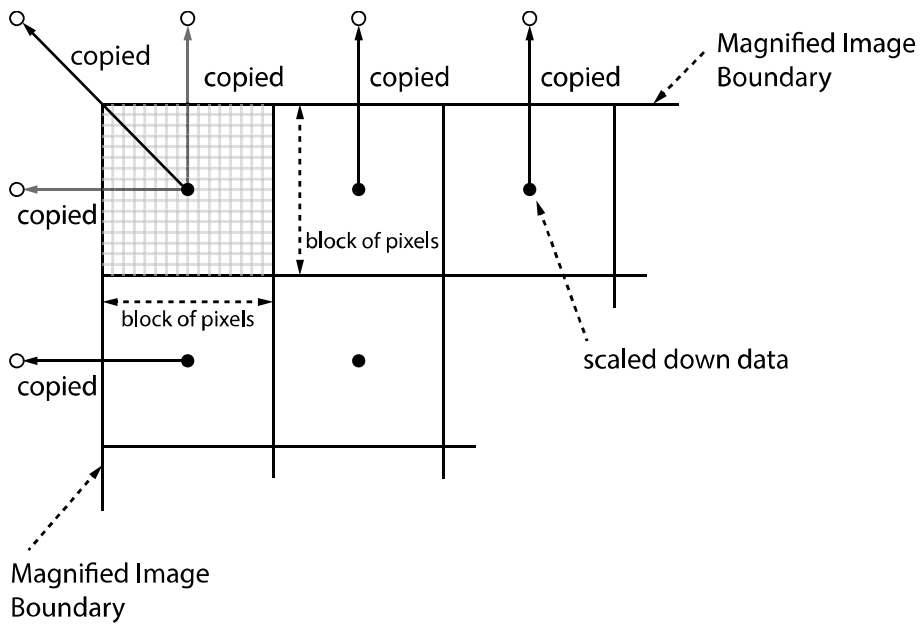

Figure 9-11 Bilinear Interpolated Magnification

The XML parameters related to Flat Field Correction are as follows.

XML Parameters		Value	Description
FlatFieldControl	FlatFieldCorrection	Off	Disables the Flat Field Correction feature.
		On	Enables the Flat Field Correction feature.
	FlatFieldData Selector	Space0 - Space15	Selects a location to save Flat Field data to or load Flat Field data from. Space0~Space15:User defined location
	FlatFieldTargetSelector	Auto	Auto-adjusts the target value of the image after correction.
		User Set	Manually sets the target value of the image after correction.
	FlatFieldTargetLevel	8bit: 1-255 12bit: 1 – 4095	Sets the target value of the image after correction when Flat Field Target Selector is set to User Set. <ul style="list-style-type: none"> <li>The setting range is based on the 12-bit Pixel Format.</li> </ul>
	FlatFieldData Generate	-	Generates the Flat Field data.
	FlatFieldDataSave	-	Saves the generated Flat Field correction data in the non-volatile memory. The data generated by executing the Flat Field Data Generate parameter are saved in the volatile memory so that the data are lost if the camera is reset or if power is turned off. To use the data after the camera is powered on or reset, save them in the non-volatile memory.
	FlatFieldDataLoad	-	Loads the Flat Field data from the non-volatile memory into volatile memory.

Table 9-19 XML Parameters related to Flat Field Correction

### 9.15.1 Flat Field Data Selector

As mentioned above, the generated Flat Field correction data are stored in the camera's volatile memory and the data are lost if the camera is reset or powered off. To use the generated Flat Field correction data after the camera is powered on or reset, you need to save them in the camera's non-volatile memory. The VC-103MC-M/C7I camera provides sixteen reserved locations in the camera's non-volatile memory available for saving and loading the Flat Field correction data. You can use the **Flat Field Data Selector** parameter to select a location as desired.

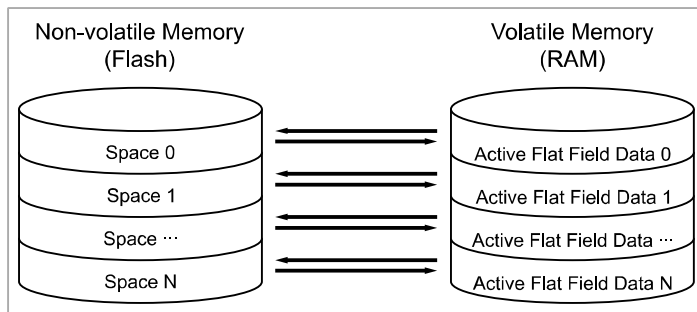

Figure 9-12 Flat Field Data Selector

#### Saving Flat Field Data

In order to save the active Flat Field data into a reserved location in the camera's Flash memory, follow the procedure below.

1. Use the **Flat Field Data Selector** parameter to specify a location to save the active Flat Field data.
2. Execute the **Flat Field Data Save** parameter to save the active Flat Field data to the selected location.

#### Loading Flat Field Data

If you saved Flat Field correction data into the camera's non-volatile memory, you could load the saved Flat Field correction data from the camera's non-volatile memory into the camera's active Flat Field data location.

1. Use the **Flat Field Data Selector** parameter to specify a reserved location whose Flat Field correction data will be loaded into the camera's active Flat Field data location.
2. Execute the **Flat Field Data Load** parameter to load the selected Flat Field correction data into the active Flat Field data location.

## 9.16 Timestamp

VC-103MC-M/C7I camera provides a Timestamp feature.

XML parameters related to Timestamp are as follows.

XML Parameters		Description
DeviceControl	Timestamp	Indicates the current Timestamp value of the connected device.
	TimestampIncrement	Indicates the increment of Timestamp.
	TimestampReset	Changes the current Timestamp value into 0 and restarts counting.
	TimestampResetValue	Designates time to reset Timestamp as 0, by the form in the numeric value.
	TimestampLatch	Latches the current value of Timestamp.
	TimestampLatchValue	Indicates prior value before resetting the Timestamp value.

Table 9-20 XML Parameters related to Timestamp

## 9.17 Event Control

VC-103MC-M/C7I camera provides an Event Notification feature. With the Event Notification feature, the camera can generate an event and transmit a related event message to the PC whenever a specific situation has occurred.

The VC-103MC-M/C7I camera can generate and transmit events for the following type of situation:

- When the TestEventGenerate parameter is executed (Test)

XML parameters related to Event Control are as follows.

XML Parameters		Value	Description
EventControl	EventSelector	Test	Transfers the Test event generated from the execution of the TestEventGenerate parameter.
	Event Notification	On	Enables the selected event notification.
		Off	Disables the selected event notification.
TestControl	TestPendingAck	-	Sets time to wait before writing the device's pending acknowledge feature.
	TestEventGenerate	-	Generates a Test event.

Table 9-21 XML Parameters related to Event Control

### 9.18 Digital I/O Control

The Control I/O receptacle of the camera can be operated in various modes.

The XML parameters related to Digital I/O Control are as follows.

XML Parameters	Value	Description	
DigitalIOControl	LineSelector	Line0	Configures the items related to the pins of No.2 and No.3 among 6 of the pins.
		Line1	Configures the items related to the pin No.4 among 6 of the pins.
LineMode	Input	Appears under Line0 is chosen.	
	Output	Appears under Line1 is chosen.	
LineInverter	FALSE	Disables inversion on the output signal of the line.	
	TRUE	Enables inversion on the output signal of the line.	
LineSource	Off	Disables the line output.	
	Exposure Active	Outputs pulse signals indicating the current exposure time.	
	Frame Active	Outputs pulse signals indicating a frame readout time.	
	UserOutput0	Outputs pulse signals set by User Output Value.	
	Timer0 Active	Outputs user-defined Timer signals as pulse signals.	
UserOutput Selector	UserOutput0	Outputs pulse signals set by User Output Value.	
UserOutput Value	FALSE	Sets the bit state of the line to Low.	
	TRUE	Sets the bit state of the line to High.	
Debounce Time	0 ~ 1,000,000	Sets a Debounce Time in microseconds (Default: 0.5 $\mu$ s).	

Table 9-22 XML Parameters related to Digital I/O Control

When you set the **Line Source** to **UserOutput0**, you can use the user setting values as output signals.

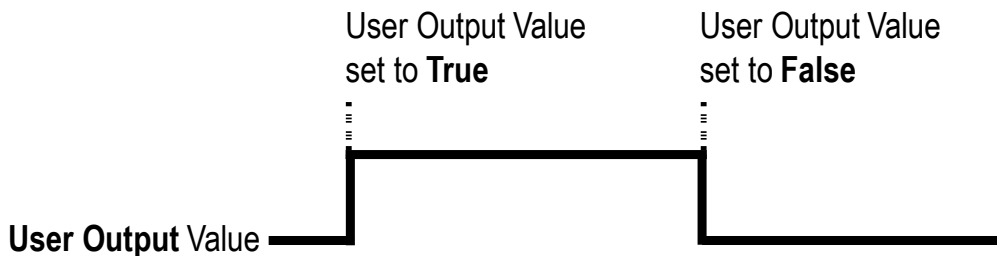

Figure 9-13 User Output



The camera can provide an **Exposure Active** output signal. The signal goes high when the exposure time for each frame acquisition begins and goes low when the exposure time ends as shown in the figure below. This signal can be used as a flash trigger and is also useful when you are operating a system where either the camera or the object being imaged is movable. Typically, you do not want the camera to move during exposure. You can monitor the **Exposure Active** signal to know when exposure is taking place and thus know when to avoid moving the camera.

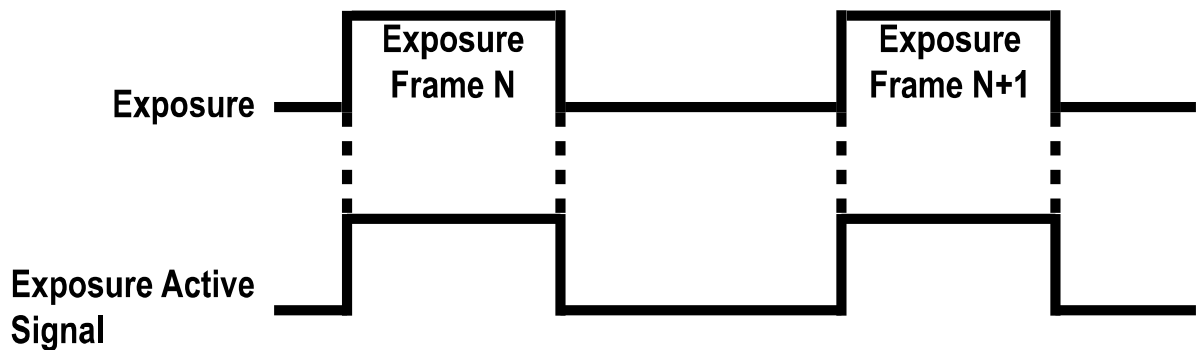

Figure 9-14 Exposure Active Signal

### 9.19 Debounce

The Debounce feature of the VC-103MC-M/C7I cameras allows to supply only valid signals to the camera by discriminating between valid and invalid input signals. The **Debounce Time** parameter specifies the minimum time that an input signal must remain High or Low in order to be considered as a valid input signal. When you use the **Debounce** feature, be aware that there is a delay between the point where the valid input signal arrives and the point where the signal becomes effective. The duration of the delay is determined by the Debounce Time parameter setting value.

When you set the Debounce Time parameter, High and Low signals shorter than the setting value are considered invalid and ignored as shown in the figure below.

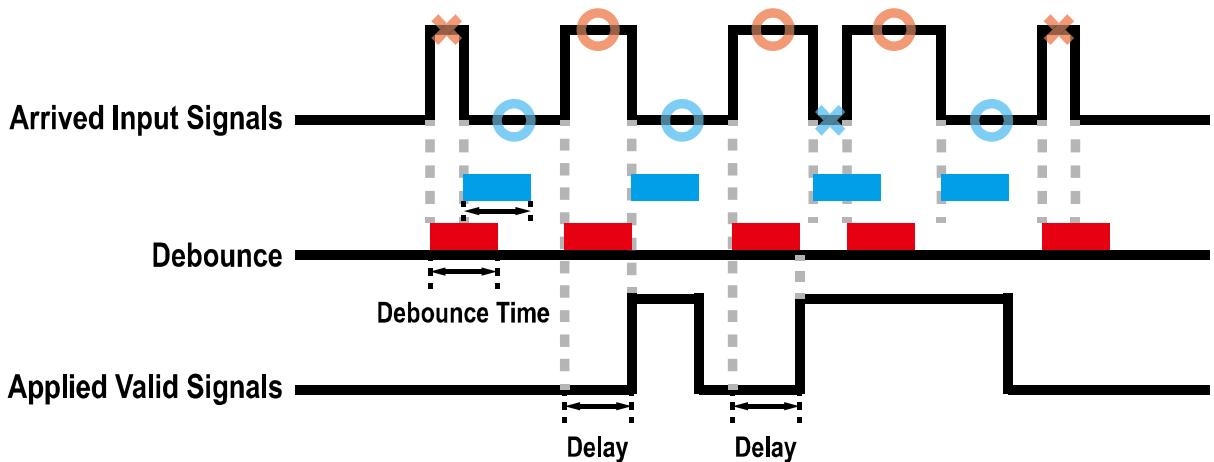

Figure 9-15 Debounce

The XML parameter related to Debounce Time is as follows.

XML Parameters	Value	Description
DigitalIOControl Debounce Time	0 – 1,000,000 $\mu$ s	Sets a Debounce Time in microseconds (Default: 0.5 $\mu$ s).

Table 9-23 XML Parameter related to Debounce Time

## 9.20 Timer Control

When the **Line Source** parameter is set to **Timer0Active**, the camera can provide output signals by using the Timer. On the VC-103MC-M/C7I camera, the Frame Active, Exposure Active event or external trigger signal is available as Timer source signal.

The XML parameters related to Timer are as follows.

XML Parameters	Value	Description	
CounterAnd TimerControl	TimerSelector	Timer0	Selects a Timer to configure.
	TimerDuration	1 ~ 60,000,000 $\mu$ s	Sets the duration of the Timer output signal to be used when Timer Trigger Activation is set to Rising/Falling Edge.
	TimerDelay	0 ~ 60,000,000 $\mu$ s	Sets the delay time to be applied before starting the Timer.
	TimerReset	-	Resets the Timer and starts it again.
	TimerValue	-	Displays the current value of the selected Timer.
TimerStatus	TimerIdle		Indicates that the Timer is in idle state.
	TimerTriggerWait		Indicates that the Timer is waiting for a trigger signal.
	TimerActive		Indicates that the Timer is in active state.
TimerTrigger Source	Off		Disables the Timer trigger.
	ExposureActive		Sets the Timer to use the current exposure time as the source signal.
	FrameActive		Sets the Timer to use a frame readout time as the source signal.
TimerTrigger Activation	Line0		Sets the Timer to use the external trigger signal as the source signal.
	RisingEdge		Specifies that a rising edge of the selected trigger signal will act as the Timer trigger.
	FallingEdge		Specifies that a falling edge of the selected trigger signal will act as the Timer trigger.
	AnyEdge		Specifies that a rising edge or a falling edge of the selected trigger signal will act as the Timer trigger.
	LevelHigh		Specifies that the Timer output signal will be valid as long as the selected trigger signal is High.
	LevelLow		Specifies that the Timer output signal will be valid as long as the selected trigger signal is Low.

Table 9-24 XML Parameters related to Timer Control

For example, when the **Timer Trigger Source** is set to **Exposure Active** and the **Timer Trigger Activation** is set to **Level High**, the Timer will act as follows.

1. When the source signals set by the **Timer Trigger Source** parameter are applied, the Timer will start operations.
2. The delay set by the **Timer Delay** parameter begins to expire.
3. When the delay expires, the Timer signal goes high as long as the source signal is high.

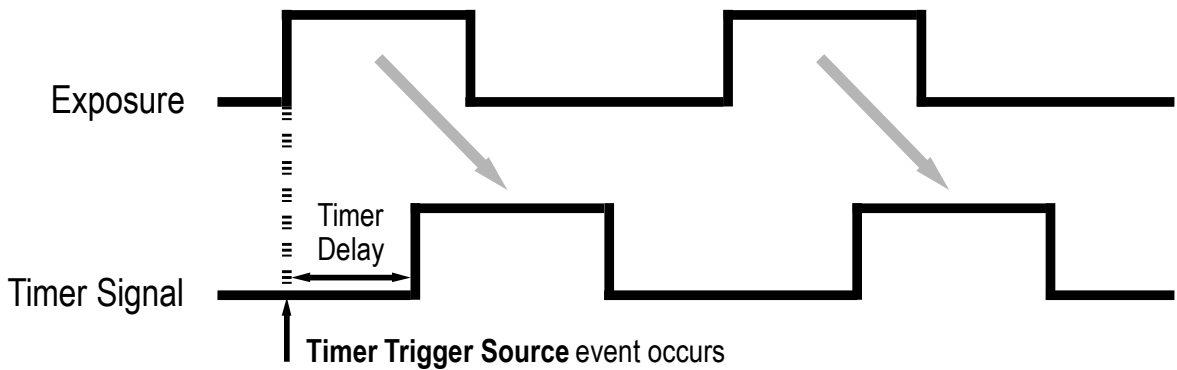

\* **Timer Trigger Activation** is set to **Level High**.

Figure 9-16 Timer Signal

### 9.21 Cooling Control

A fan is installed on the rear panel of the camera to radiate heat. You can set the fan to turn on or off. You can also set the fan to turn on when a specified internal temperature is reached.

The XML parameters related to Cooling Control are as follows.

XML Parameters	Value	Description
CoolingControl TargetTemperature	-10°C ~ 80°C	Turns on the fan automatically when the temperature set in this parameter.
FanOperationMode	Off	Turns off the fan.
	On	Turns on the fan.
FanSpeed	-	Displays the current Fan RPM.

Table 9-25 XML Parameters related to Cooling Control

## 9.22 Temperature Monitor

The camera has an embedded sensor chip to monitor the internal temperature.

The XML parameters related to Device Temperature are as follows.

XML Parameters		Value	Description
DeviceControl	DeviceTemperatureSelector	Mainboard	Sets a temperature measuring spot to the mainboard.
	DeviceTemperature	-	Displays device temperature in Celsius.

Table 9-26 XML Parameters related to Device Temperature

## 9.23 Status LED

A LED is installed on the rear panel of the camera to inform the operation status of the camera.

LED status and corresponding camera status are as follows:

Status LED	Description
Steady Red	The camera is not initialized.
Fast Flashing Orange	The camera is transmitting image data.
Steady Green	A Camera Link stands by.

Table 9-27 Status LED

## 9.24 Test Pattern

To check whether the camera operates normally or not, it can be set to output test patterns generated in the camera, instead of image data from the image sensor. Four types of test patterns are available; images with different values in horizontal direction (Grey Horizontal Ramp), images with different values in diagonal direction (Grey Diagonal Ramp), moving images with different values in diagonal direction (Grey Diagonal Ramp Moving) and images with different values in horizontal direction output from the image sensor (Sensor Specific).

The XML parameter related to Test Pattern is as follows.

XML Parameter	Value	Description	
ImageFormatControl	TestPattern	Off	Disables the Test Pattern feature.
	GreyHorizontalRamp	GreyHorizontalRamp	Sets to Grey Horizontal Ramp.
	GreyDiagonalRamp	GreyDiagonalRamp	Sets to Grey Diagonal Ramp.
	GreyDiagonalRamp Moving	GreyDiagonalRamp Moving	Sets to Grey Diagonal Ramp Moving.
	SensorSpecific	SensorSpecific	Sets to the Test Pattern generated by the image sensor.

Table 9-28 XML Parameter related to Test Pattern

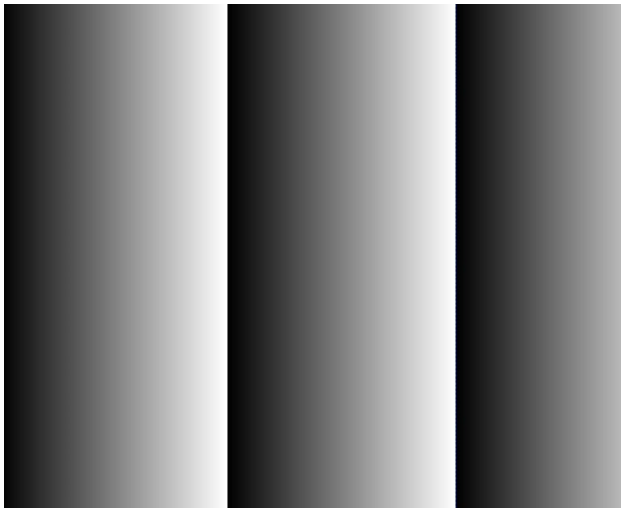

Figure 9-17 Grey Horizontal Ramp



Figure 9-18 Grey Diagonal Ramp



Figure 9-19 Grey Diagonal Ramp Moving

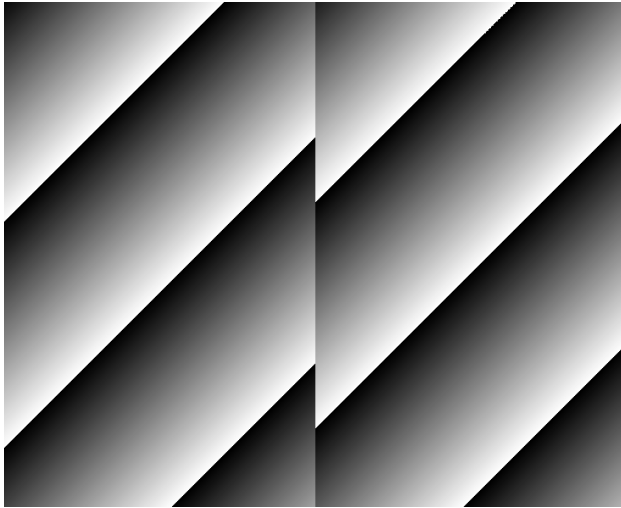

Figure 9-20 Sensor Specific



**Note:**

The test pattern may look different because the region of the test pattern may vary depending on the camera's resolution.

---



## 9.25 Reverse X

The Reverse X feature lets you flip images horizontally. This feature is available in all operation modes of the camera.

The XML parameter related to Reverse X is as follows.

XML Parameters	Value	Description
ImageFormatControl ReverseX	FALSE	Disables the Reverse X feature.
	TRUE	Flips images horizontally.

Table 9-29 XML Parameter related to Reverse X



Figure 9-21 Original Image

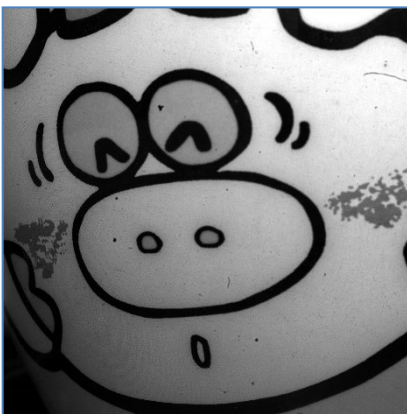

Figure 9-22 Reverse X Image

## 9.26 Reverse Y

The Reverse Y feature lets you flip images vertically. This feature is available in all operation modes of the camera.

The XML parameter related to Reverse Y is as follows.

XML Parameters	Value	Description
ImageFormatControl ReverseY	FALSE	Disables the Reverse Y feature.
	TRUE	Flips images vertically.

Table 9-30 XML Parameter related to Reverse Y



Figure 9-23 Original Image

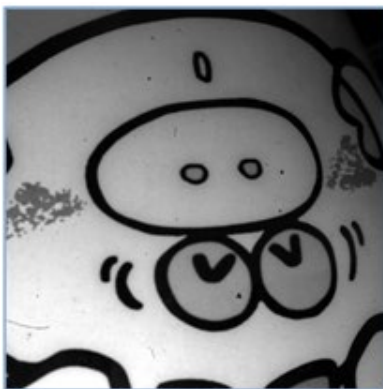

Figure 9-24 Reverse Y Image



### Note:

- When using the Reverse Y feature, it is recommended to regenerate the camera's correction data(DSNU, PRNU), and readjust the Black Level value(refer to 9.1)
- To apply the new color filter array to the color cameras in the series, it is recommended to execute the **Reverse Y** feature after choosing **Bayer** on the **Pixel Format** parameter.

## 9.27 Device Link Throughput Limit

The **Device Link Throughput Limit** feature allows you to limit the maximum available bandwidth for data transmission to your computer.

The XML parameter related to Device Link Throughput Limit is as follows.

XML Parameters		Description
DeviceControl	DeviceLinkThroughputLimit	Limits the maximum available bandwidth (bps).

Table 9-31 XML Parameter related to Device Link Throughput Limit



### Caution!

To ensure good image quality, we recommend that you set the **Device Link Throughput Limit** parameter to the maximum value. Otherwise, the image quality can decrease. In case of the VC-103MC-M/C7I, its maximum value is 8000.

## 9.28 Device User ID

You can input user-defined information up to 16 bytes.

The XML parameter related to Device User ID is as follows.

XML Parameters		Description
DeviceControl	DeviceUserID	Input user defined information (16 bytes).

Table 9-32 XML Parameter related to Device User ID

## 9.29 Device Reset

Resets the camera physically to power off and on. You must connect to the network again because the camera will be released from the network after reset.

The XML parameter related to Device Reset is as follows.

XML Parameters		Description
DeviceControl	DeviceReset	Resets the camera physically.

Table 9-33 XML Parameter related to Device Reset

### 9.30 Field Upgrade

The camera provides a feature to upgrade the Firmware and FPGA logic through the Gigabit Ethernet interface rather than disassemble the camera in the field. Refer to [Appendix B](#) for more details about how to upgrade.

### 9.31 User Set Control

You can save the current camera settings to the camera's internal Flash memory. You can also load the camera settings from the camera's internal Flash memory. The camera provides two setups to save and three setups to load settings.

The XML parameters related to User Set Control are as follows.

XML Parameters	Value	Description	
UserSetControl	UserSetSelector	Default	Selects the Factory Default settings.
		UserSet1	Selects the UserSet1 settings.
		UserSet2	Selects the UserSet2 settings.
UserSetLoad	-	Loads the User Set specified by User Set Selector to the camera.	
UserSetSave	-	Saves the current settings to the User Set specified by User Set Selector. The Default is a Factory Default Settings and allowed to load only.	
UserSetDefault		Default	Applies the Factory Default settings when reset.
		UserSet1	Applies the UserSet1 when reset.
		UserSet2	Applies the UserSet2 when reset.

Table 9-34 XML Parameters related to User Set Control

The camera settings stored in the Default can be loaded into the camera's workspace, but cannot be changed. The settings set in the workspace will be lost if the camera is reset or powered off. To use the current setting values in the workspace after a reset, you must save the settings to one of the user spaces.

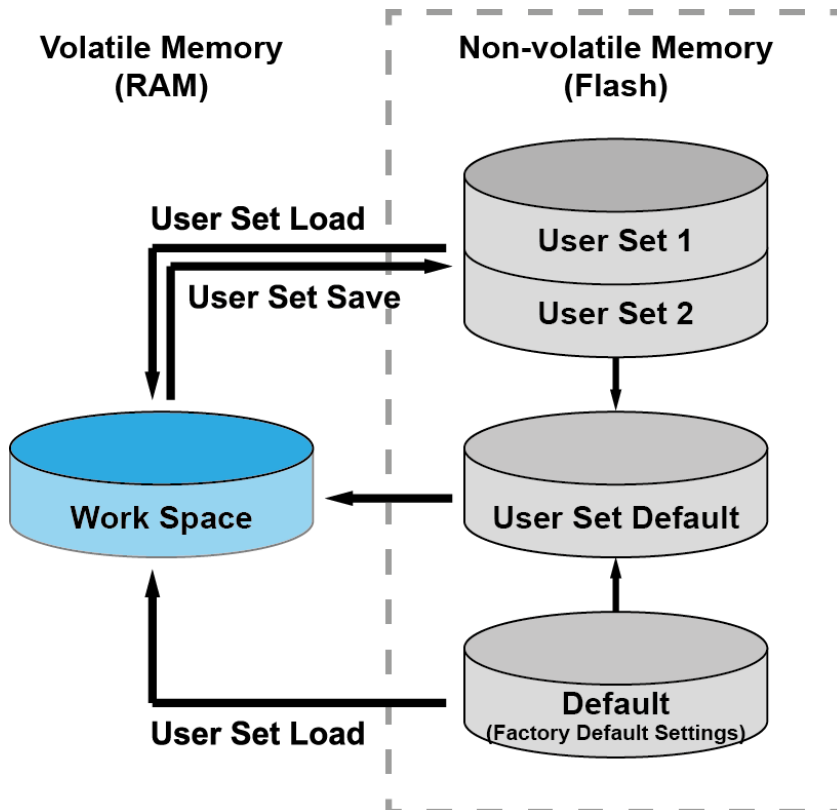

Figure 9-25 User Set Control

## 9.32 Sequencer Control

The Sequencer Control provided by the VC-103MC-M/C7I camera allows you to apply different sets of parameter setting, called 'Sequencer Set', to a sequence of image acquisitions. As the camera acquires images, it applies one Sequencer Set after the other. This allows you to respond quickly to changing imaging requirements. For example, changes in illumination conditions influence the imaging requirements. With the **User Set Control** feature, you can save user-defined Sequencer Sets in the camera's non-volatile memory. Then after the camera is powered on or reset, the Sequencer Sets are available according to the **User Set Default** parameter. Each Sequencer Set is identified by an index number ranging from 0 to 31. Accordingly, you can define up to 32 different Sequencer Sets.

On the VC-103MC-M/C7I camera, the Flat Field correction data, Gain and Exposure Time settings can be configured for Sequencer Sets.

The XML parameters related to Sequencer Control are as follows.

XML Parameters		Value	Description
Sequencer Control	SequencerMode	Off	Disables the Sequencer.
		On	Enables the Sequencer.
	Sequencer ConfigurationMode	Off	Disables the Sequencer Configuration Mode.
		On	Enables the Sequencer Configuration Mode.
	Sequencer FeatureSelector	FlatFieldData	Selects a feature to be applied to Sequencer Sets.
		GainDigitalAll	
		ExposureTime	
	Sequencer FeatureEnable	Off	Disables the selected feature for the application of Sequencer Sets.
		On	Enables the selected feature for the application of Sequencer Sets.
	Sequencer SetSelector	0 – 31	Selects an index number of a Sequencer Set to be configured.
SequencerSetActive	-	Displays the index number (0 - 31) of the Sequencer Set that is currently active.	
SequencerSetCount	1 – 32	Sets the number of Sequencer Sets to be applied.	
SequencerReset	-	Returns to Sequencer Set 0.	

Table 9-35 XML Parameters related to Sequencer Control



**Note:**

To apply Sequencer Sets, you must first set the **Trigger Mode** parameter to **On**.

## Use Case – Applying Four Different Sets of Flat Field Correction Data, Gain and Exposure Time Settings to Sequencer Sets

For example, assume that four different sets of Flat Field correction data, Gain and Exposure settings optimized for White, Green, Red and Blue pixels are applied to four different Sequencer Sets to inspect LCD panels.

1. Set the **Sequencer Mode** parameter to **Off**.
2. Select a feature to be applied to Sequencer Sets by using the **Sequencer Feature Selector** parameter.

You must select features to be applied to Sequencer Sets prior to entering the **Sequencer Configuration Mode**.

Set the **Sequencer Feature Selector** parameter to **Flat Field Data Selector**, and then set the **Sequencer Feature Enable** parameter to **On**.

Set the **Sequencer Feature Selector** parameter to **Gain Digital All**, and then set the **Sequencer Feature Enable** parameter to **On**.

Set the **Sequencer Feature Selector** parameter to **Exposure Time**, and then set the **Sequencer Feature Enable** parameter to **On**.

3. Set the **Sequencer Configuration Mode** parameter to **On**.
4. Set the **Sequencer Set 0** first.

Set the **Sequencer Set Selector** parameter to **0**, and then set the **Flat Field Data Selector** parameter to **Space0** in the **Flat Field Control** category. Then, set the **Gain** parameter to **1** in the **Analog Control** category, and then set the **Exposure Time** parameter to 10000 in the **Acquisition Control** category.

5. By following the procedure in the step 4, set the **Sequencer Set 1**, **Sequencer Set 2** and **Sequencer Set 3** as shown below.

Sequencer Set 1 → Flat Field Data Selector = Space 1, Gain = 2, Exposure Time = 20000

Sequencer Set 2 → Flat Field Data Selector = Space 2, Gain = 3, Exposure Time = 30000

Sequencer Set 3 → Flat Field Data Selector = Space 3, Gain = 4, Exposure Time = 40000

6. Set the **Sequencer Set Count** parameter to **4**.
7. Set the **Sequencer Configuration Mode** parameter to **Off**, and then set the **Sequencer Mode** parameter to **On**.

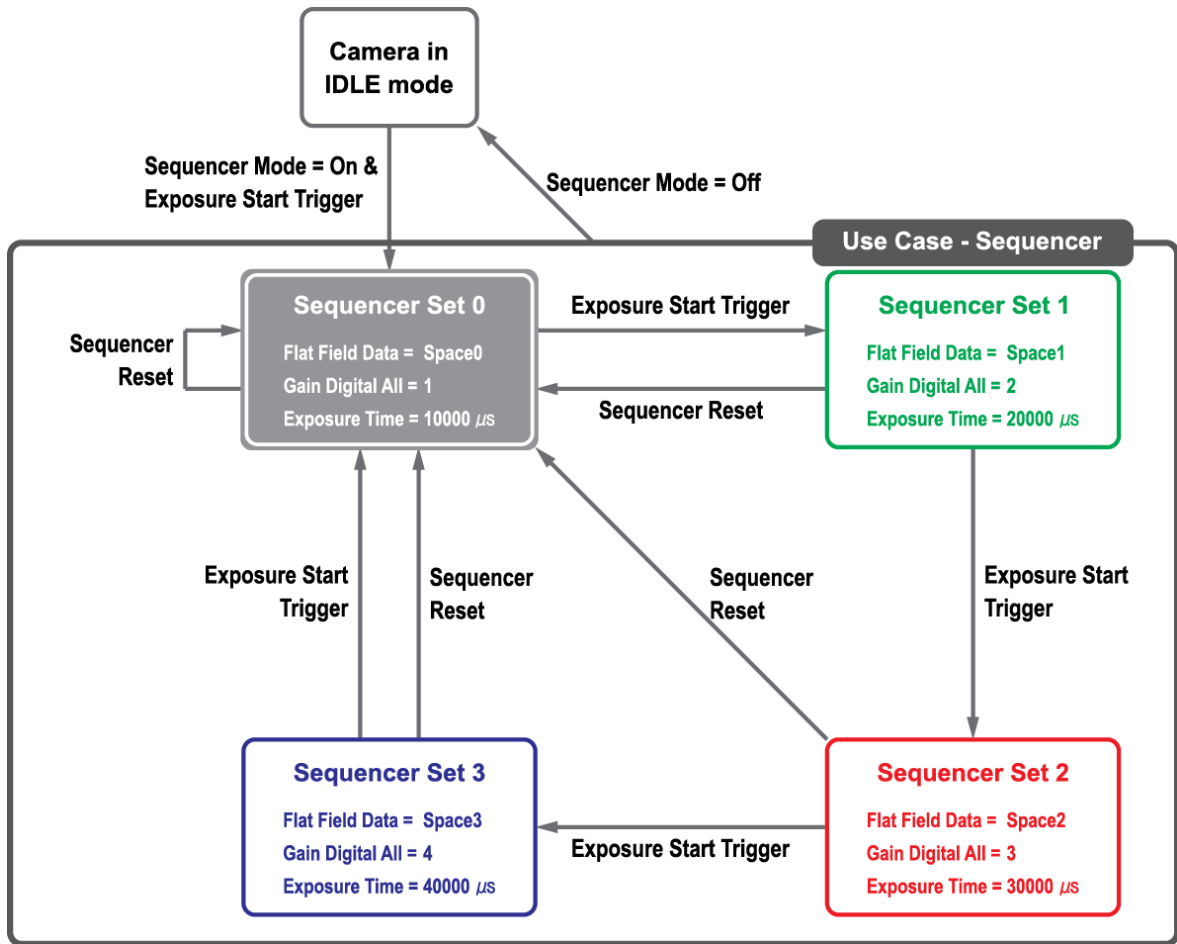

Figure 9-26 Sequencer Diagram (Use Case)



**Note:**

- When you set the **Sequencer Configuration Mode** parameter to **On**, the following features will be enabled for the application of Sequencer Sets by default.  
Flat Field Data Selector = Enabled, Space0  
Gain Digital All = Enabled, Gain = 1  
Exposure Time = Enabled, 10000
- You can save the user-defined Sequencer Sets in the camera's non-volatile memory by using the **User Set Control** feature. For more information, refer to [9.31 User Set Control](#).
- Executing the **Sequencer Reset** parameter allows to return to the Sequencer Set 0 status at any time while cycling through the Sequencer.



## Chapter 10. Camera Configuration

### 10.1 Serial Communication

You can configure all camera settings via RS-644 serial communication of the Camera Link interface. When you want to control the camera by using a terminal or access directly to the camera by using your application, you need to set your network as follows:

- Baud Rate: 115200 bps
- Data Bit: 8 bit
- Parity Bit: No parity
- Stop Bit: 1 stop bit
- Flow Control: None

### 10.2 Actual Runtime of Parameters

When you set a parameter, the actual runtime of the parameter varies depending on the type of the parameter and the operating status of the camera. All parameters except the Exposure Time parameter are applied to change the camera settings as illustrated below, on the rising edge of a REQ\_Frame signal before starting the readout process. When you change the Exposure Time parameter, the exposure time setting will be changed and applied at the starting of the exposure.

If you operate the camera with the **Trigger Mode** parameter set to **On**, you must change parameters before applying the trigger signals in order to synchronize image outputs with the parameters. If you change a parameter in the Free-Run mode, you may acquire up to two lines that are not affected by the parameter change. This is true because it is hard to verify the current operating status of the camera in the Free-Run mode.

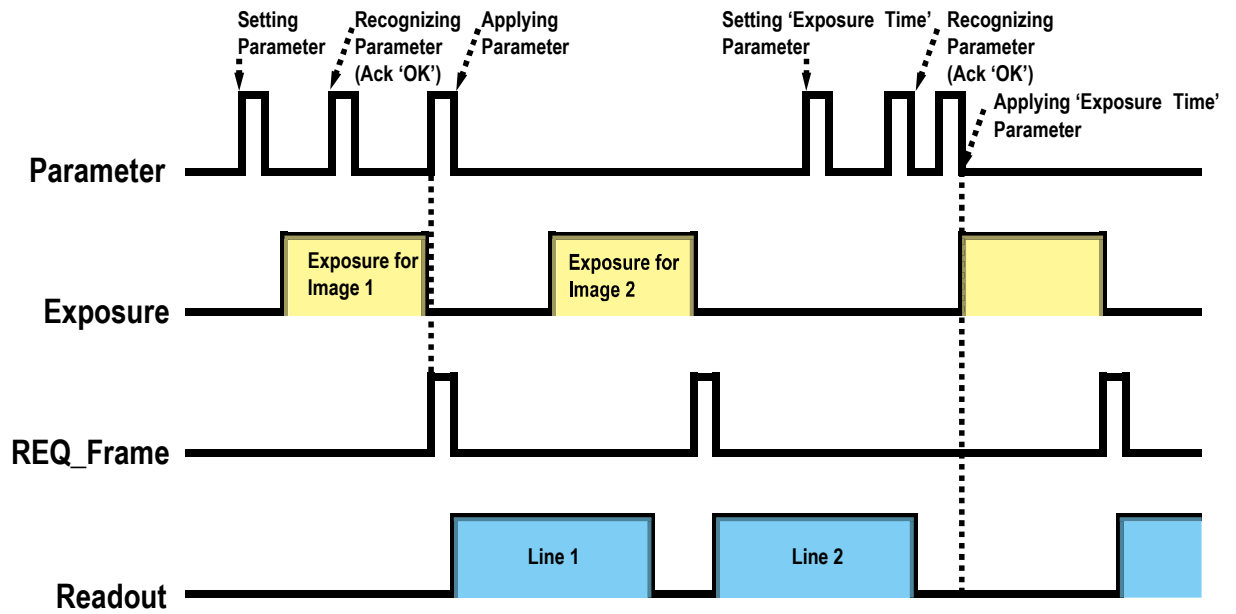

Figure 10-1 Actual Runtime of Parameters

## 10.3 Configurator

The Configurator, a sample application, is provided to control Vieworks Camera Link cameras. The Configurator allows you to change the camera's parameters and control the camera.

### 10.3.1 Starting the Configurator

After connecting the camera to your computer (refer to [Chapter 6 Connecting the Camera](#)), you can run the Configurator by following the procedure below.

1. Execute the [Configurator.exe](#) file after the camera is powered on. The [Camera Scan](#) window appears.
2. The [Configurator](#) probes if a camera is connected to your computer and then displays the model name of the connected camera in the [Camera Scan](#) window.
3. Right-click the model name of the camera, and then click the [Add to List](#) menu. By adding a Vieworks Camera Link camera which supports XML-based control to the list, you can configure the camera with a newer version of the [Configurator](#).

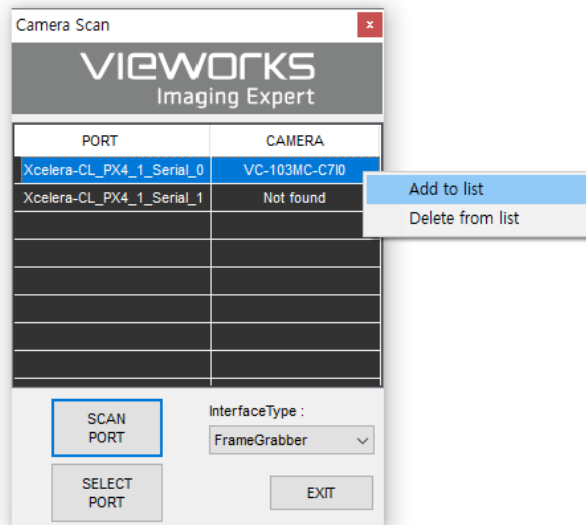

Figure 10-2 Add to list in the Camera Scan window

4. Double-click the model name of the camera. The **DeviceProperty** and **Configurator Plus** windows appear.

The **DeviceProperty** window displays controls for setting camera parameters.

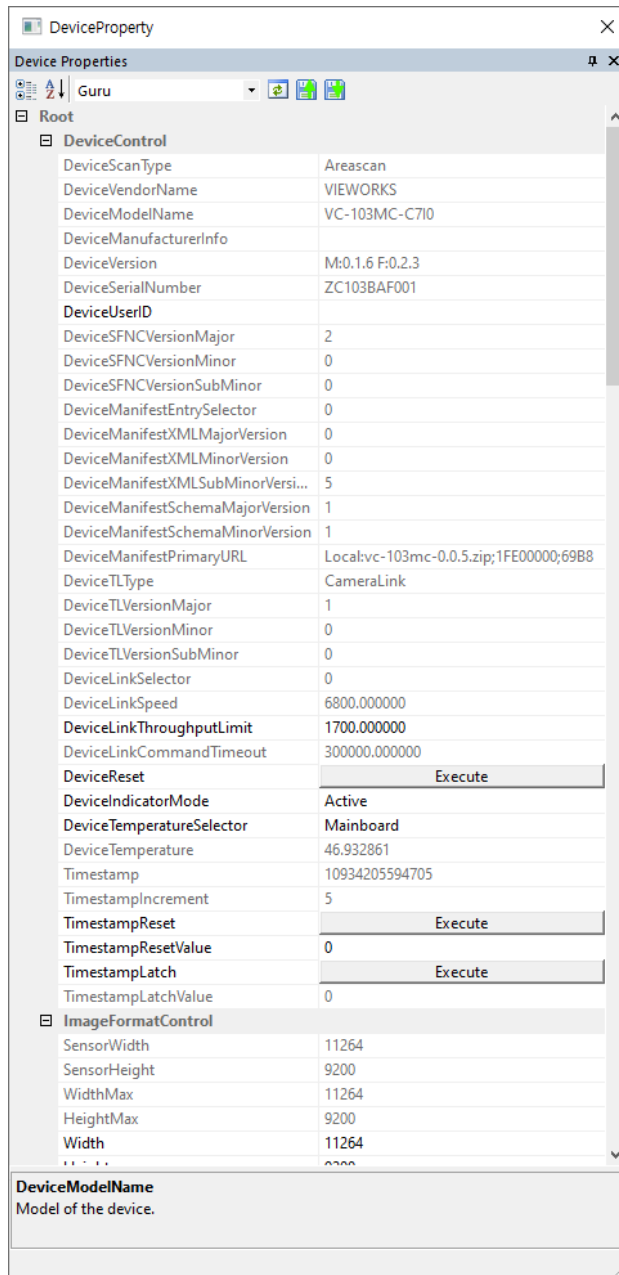

Figure 10-3 Device Property

In the **Configurator Plus** window, you can display the **Device Property** and/or **Device Maintenance** windows. In the **Device Maintenance** window, you can download a Defective Pixel Map or upgrade camera's MCU, FPGA and XML files.

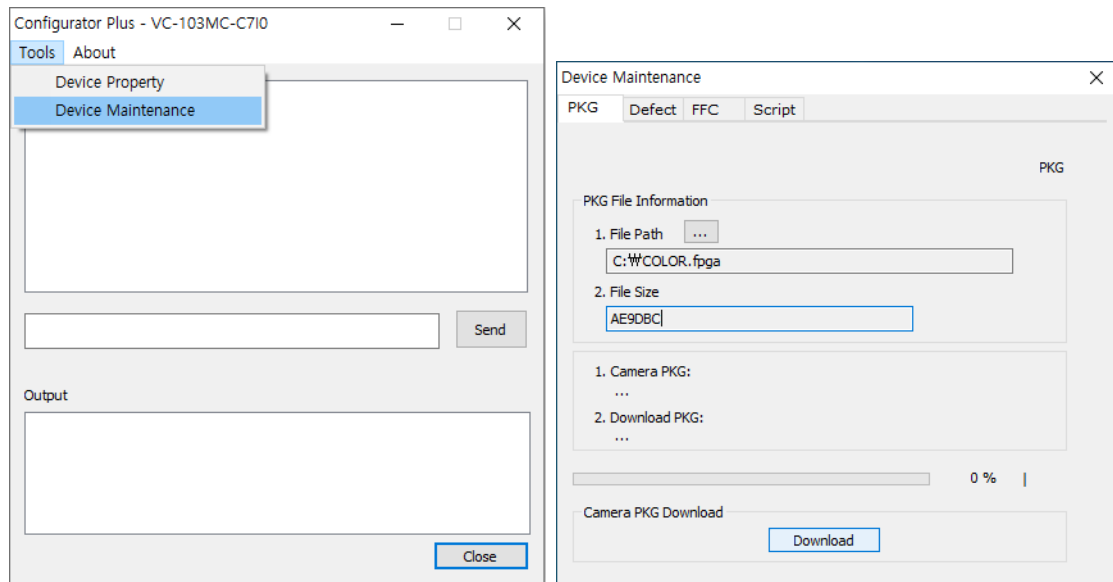

Figure 10-4 Configurator Plus and Device Maintenance

## 10.4 Command List

You can also set all features provided by the VC-103MC-M/C7I cameras by using the following commands.

Command	Syntax	Return Value	Description
Help	help	String	Displays a list of all commands.
Set ROI Offset X Get ROI Offset X	sox n gox	OK n	X coordinate of start point ROI n: X axis offset
Set ROI Offset Y Get ROI Offset Y	soy n goy	OK n	Y coordinate of start point ROI n: Y axis offset
Set Image Width Get Image Width	siw n giw	OK n	Sets a width of the Image ROI. n: Width value
Set Image Height Get Image Height	sih n gih	OK n	Sets a height of the Image ROI. n: Height value
Set Region Selector Get Region Selector	srs n grs	OK n	Selects a ROI to set when setting the Multi-ROI. n: Index number of a ROI
Set Region Mode Get Region Mode	src 0   1 grc	OK 0   1	Enables / Disables the selected ROI when setting the Multi-ROI. 0: Disables the selected ROI. 1: Enables the selected ROI.
Set Region Offset X Get Region Offset X	srx n grx	OK n	Sets a horizontal offset from the origin to the selected ROI when setting the Multi-ROI. n: X axis offset
Set Region Offset Y Get Region Offset Y	sry n gry	OK n	Sets a vertical offset from the origin to the selected ROI when setting the Multi-ROI. n: Y axis offset
Set Region Width Get Region Width	srw n grw	OK n	Sets a width for the selected ROI when setting the Multi-ROI. n: Width value
Set Region Height Get Region Height	srh n grh	OK n	Sets a height for the selected ROI when setting the Multi-ROI. n: Height value

Table 10-1 Command List #1

Command	Syntax	Return Value	Description
Set Test Image	sti 0 1 2 3 16	OK	Sets the Test Image.
Get Test Image	gti	0 1 2 3 16	0: Disables the Test Image feature. 1: Sets to Grey Horizontal Ramp. 2: Sets to Grey Diagonal Ramp. 3: Sets to Grey Diagonal Ramp Moving. 16: Sets to the Test Image provided by the image sensor.
Set Camera Link Tap Geometry	stg 2 4 8 10	OK	Sets the Camera Link Tap Geometry.
Get Camera Link Tap Geometry	gtg	2 4 8 10	2: 1X2-1Y (2 taps) 4: 1X4-1Y (4 taps) 8: 1X8-1Y (8 taps) 10: 1X10-1Y (10 taps)
Set Data Bit	sdb 8 10 12	OK	Sets the Pixel Format.
Get Data Bit	gdb	8 10 12	8: 8 bit 10: 10 bit 12: 12 bit
Set Defect Correction	sdc 0 1	OK	Sets the Defect Pixel Correction.
Get Defect Correction	gdc	0 1	0: Disables the Defect Pixel Correction. 1: Enables the Defect Pixel Correction.
Set Horizontal Flip	shf 0 1	OK	Sets the Reverse X (Horizontal Flip).
Get Horizontal Flip	ghf	0 1	0: Disables the Reverse X. 1: Enables the Reverse X.
Set Vertical Flip	svf 0 1	OK	Sets the Reverse Y (Vertical Flip).
Get Vertical Flip	gvf	0 1	0: Disables the Reverse Y. 1: Enables the Reverse Y.
Acquisition Start	ast	OK	Starts image acquisitions.
Acquisition Stop	asp	OK	Stops image acquisitions.

Table 10-2 Command List #2

Command	Syntax	Return Value	Description
Set Frame Rate Get Frame Rate	sfr n gfr	OK n	Sets the rate at which the exposure start trigger will be generated when the Trigger Mode is set to Off.
Get Acquisition Status	gast	0 1	Retrieves the internal acquisition status. 0: The camera is not in the process of acquiring a frame. 1: The camera is in the process of acquiring a frame.
Set Trigger Mode Get Trigger Mode	stm 0 1 gtm	OK 0 1	Sets the Trigger Mode. 0: Trigger Mode Off (Free run mode) 1: Trigger Mode On
Set Trigger Source Get Trigger Source	sts 3 10 14 18 22 gts	OK 3 10 14 18 22	Specifies a source signal when the Trigger Mode is set to On. 3: Software 10: User Output0 14: CC1 18: Timer0 Active 22: Line0
Generate SW Trigger	gst	OK	Generates a Software trigger signal.
Set Trigger Activation Get Trigger Activation	sta 0 1 gta	OK 0 1	Sets the activation mode for the selected source signal when the Trigger Mode is set to On. 0: Falling Edge 1: Rising Edge
Set Exposure Mode Get Exposure Mode	sem/ses 0 1 gem/ges	OK 0 1	Sets the Exposure Mode. 0: Timed 1: Trigger Width
Set Exposure Time Get Exposure Time	set n get	OK n	Sets an exposure time. n: Exposure time in microseconds (Setting range: 1 – 60,000,000 $\mu$ s)

Table 10-3 Command List #3



Command	Syntax	Return Value	Description
Set Black Level	sbl n	OK	Sets the black level value.
Get Black Level	gbl	n	n: Black Level (Setting range: 0 – 255)
Set Digital Gain	sdg n	OK	Sets the digital gain value.
Get Digital Gain	gdg	n	n: Gain (Setting range: 1× – 32×)
Generate DSNU Data	gdd	OK	Generates the DSNU data.
Save DSNU Data	sdd	OK	Saves the generated DSNU data in the non-volatile memory.
Generate PRNU Data	gpd	OK	Generates the PRNU data.
Set PRNU Data Selector	spds 0 1 2 3	OK	Selects a PRNU data location.
Get PRNU Data Selector	gpds	0 1 2 3	0: Default location 1 – 3: User-defined locations
Save PRNU Data	spd	OK	Saves the generated PRNU correction data in the selected PRNU data location.
Load PRNU Data	lpd	OK	Loads the PRNU data from the non-volatile memory into the volatile memory.
Generate Flat Field Data	gfd	OK	Executes the Flat Field Generator.
Set Flat Field Data Selector	sfds n	OK	Selects a Flat Field correction data location.
Get Flat Field Data Selector	gfds	n	n: User-defined locations, mono 0-31, color 0-15
Save Flat Field Data	sfd	OK	Saves the generated Flat Field correction data in the selected FFC data location.
Load Flat Field Data	lfd	OK	Loads the FFC data from the non-volatile memory into the volatile memory.
Set Flat Field Correction	sfc 0 1	OK	Sets the Flat Field Correction feature.
Get Flat Field Correction	gfc	0 1	0: Disables the Flat Field Correction. 1: Enables the Flat Field Correction.
Set Fan Mode	sfm 0 1 2	OK	Sets the Fan operation mode.
Get Fan Mode	gfm	0 1 2	0: Fan Off 1: Fan On 2: Temperature
Set Target Temperature	stt n	OK	Sets the temperature to operate the fan when the Fan Mode is set to Temperature.
Get Target Temperature	ggt	n	n: -10°C - 80°C
Get Fan RPM	gfrpm	String	Displays the Fan RPM.

Table 10-4 Command List #4

Command	Syntax	Return Value	Description
Set Sequencer Mode Get Sequencer Mode	ssqm 0 1 gsqm	OK 0 1	Sets the Sequencer Mode. 0: Disables the Sequencer Mode. 1: Enables the Sequencer Mode.
Set Sequencer Config. Mode Get Sequencer Config. Mode	ssqcm 0 1 gsqcm	OK 0 1	Sets the Sequencer Configuration Mode. 0: Disables the Sequencer Config. Mode. 1: Enables the Sequencer Config. Mode.
Set Sequencer Set Selector Get Sequencer Set Selector	ssqss n gsqss	OK n	Selects an index number of a Sequencer Set to be configured. n: Sequencer Set index number (0–31)
Set Sequencer Set Count Get Sequencer Set Count	ssqsc n gsqsc	OK n	Sets the number of Sequencer Sets to be applied (n: 1 – 32).
Get Sequencer Set Active	gsqsa	n	Displays the index number of the Sequencer Set that is currently active (n: 0 – 31).
Reset Sequencer	rsq	OK	Returns to Sequencer Set 0.
Set Line Source Get Line Source	slnc 0 4 6 10 18 glnc	OK 0 4 6 10 18	Specifies a source signal for the Control I/O receptacle. 0: Off 4: Frame Active 6: Exposure Active 10: User Output0 18: Timer0 Active
Set Line Inverter Get Line Inverter	slni 0 1 glni	OK 0 1	Sets whether to invert the line output. 0: Disables inversion on the line output. 1: Enables inversion on the line output.
Set User Output Value Get User Output Value	suov 0 1 guov	OK 0 1	Sets the User Output value. 0: Sets the bit state of the line to Low. 1: Sets the bit state of the line to High.
Set Debounce Time Get Debounce Time	sdbt n gdbt	OK n	Sets the Debounce time n: Debounce time in microseconds (0 – 1,000,000 $\mu$ s)
Set Timer Duration Get Timer Duration	stdu n gtdu	OK n	Sets the duration of the Timer output signal. n: 1 – 60,000,000 $\mu$ s
Set Timer Delay Get Timer Delay	stdl n gtdl	OK n	Sets the delay time for the Timer. n: 0 – 60,000,000 $\mu$ s

Table 10-5 Command List #5

Command	Syntax	Return Value	Description
Reset Timer	rtmr	OK	Resets the Timer and starts it again.
Set Timer Trigger Source	stts 0 4 6 22	OK	Specifies a source signal for the Timer output signal. 0: Off 4: Frame Active 6: Exposure Active 22: Line0
Get Timer Trigger Source	gtts	0 4 6 22	
Set Timer Trigger Activation	stta 0 1 2 3	OK	Sets the activation mode for the Timer. 0: Falling Edge 1: Rising Edge 2: Level Low 3: Level High
Get Timer Trigger Activation	gtta	0 1 2 3	
Set AWB Offset X	swx n	OK	Sets a horizontal offset from the origin to the Data ROI.
Get AWB Offset X	gwx	n	
Set AWB Offset Y	swy n	OK	Sets a vertical offset from the origin to the Data ROI.
Get AWB Offset Y	gwy	n	
Set AWB Width	sww n	OK	Sets a width for the Data ROI.
Get AWB Width	gww	n	
Set AWB Height	swh n	OK	Sets a height for the Data ROI.
Get AWB Height	gwh	n	
Set RGB Gain	srg r g b n	OK	Sets the intensity of color pixels. r g b: Red / Green / Blue pixels n: Gain value (1.0× ~ 4.0×)
Get RGB Gain	grg r g b	n	
Auto White Balance	arg	OK	Automatically adjusts the white balance once.
Get Model Name	gmn	String	Displays the camera model name.
Get MCU Version	gmv	String	Displays the version of the camera MCU.
Get FPGA Version	gfv	String	Displays the version of the camera FPGA.
Get Serial Number	gsn piece	String	Displays the serial number of the camera.
Get Current Temperature	gct	String	Displays the device temperature in Celsius.
Reset Hardware	rst	-	Resets the camera physically to power off and on.
Load Config. From	lcf 0 1 2	OK	Loads the camera setting values. 0: Loads the Factory Default Setting. 1: Loads the User 1 Setting. 2: Loads the User 2 Setting.
Save Config. To	sct 1 2	OK	Saves the current camera setting values. 1: Saves to the User 1 Setting. 2: Saves to the User 2 Setting.
Set Config. Initialization	sci 0 1 2	OK	Specifies setting values to be loaded when reset. 0: Factory Default Setting 1: User 1 Setting 2: User 2 Setting
Get Config. Initialization	gci	0 1 2	

Table 10-6 Command List #6

## Chapter 11. Troubleshooting

When you have a problem with a Vieworks camera, please check the following:

- If no image is displayed on your computer,
  - Ensure that all the cable connections are secure.
  - Ensure that the power supply is properly connected.
  - Ensure that trigger signals are applied correctly when you operate the camera with trigger signals.
- If images are not clear,
  - Ensure the camera lens or glass is clean.
  - Check the lens aperture is adjusted properly.
- If images are dark,
  - Ensure the camera lens is not blocked.
  - Check the exposure time is set properly.
  - Check the aperture is opened properly.
  - Check the Gain value is not set too small.
- If you identify abnormal operation or overheating sign,
  - Ensure the power supply is properly connected.
  - Stop using the camera when you notice smoke or abnormal overheating.
- If you have a problem using the Trigger Mode,
  - Ensure that the Software trigger related parameters are configured correctly.
  - Ensure that cable connections are secure when you set the Trigger Source parameter to Line0.
- If there is communication failure between the camera and computer,
  - Ensure that the Camera Link cable connections are secure.
  - Ensure that you have configured a frame grabber in your computer and the camera is connected to the frame grabber correctly.

## Appendix A. Defective Pixel Map Download

1. Create the Defective Pixel Map data in Microsoft Excel format as shown in the left picture below and save as a CSV file (\*.csv). The picture in the right shows the created Excel file opened in Notepad. The following rules need to be applied when creating the file.

Lines beginning with ':' or '--' are treated as notes.

You must enter the horizontal value first and then the vertical value for coordinates of each defect pixel.

Coordinate values for each pixel can be placed in any order.

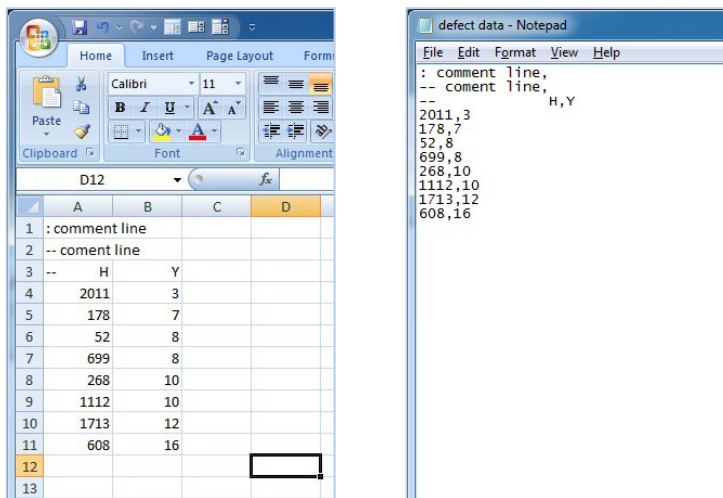

2. Run Vieworks Imaging Solution 7.X and click the **Configure** button to display the window as shown below. Select the **Defect** tab, click the File Path button, search and select the defective pixel map (\*.csv), and then click the **Download** button.

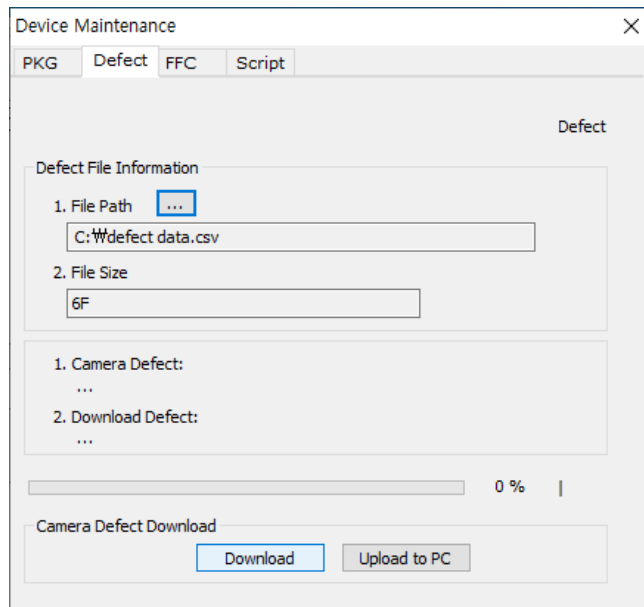

## Appendix B. Field Upgrade

You can upgrade the MCU, FPGA and XML file of the camera by following the procedure below.

1. Run the latest Configurator file from the manufacturer of the frame grabber in use.
2. Select the **PKG** tab, click the File Path button, search and select the MCU, FPGA or XML upgrade file, and then click the **Download** button.

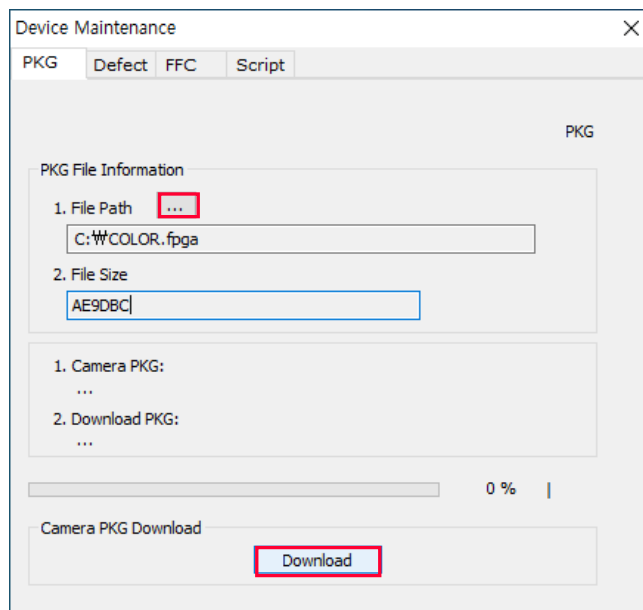

3. The camera begins downloading the upgrade file and the downloading status is displayed at the bottom of the window.

## Appendix C. Index

### 4

4-pin Hirose plug .....	31
4-pin plug .....	31

### 6

6-pin Hirose plug .....	30
6-pin plug .....	30

### A

acquisition control .....	33
Acquisition Mode	
Continuous parameter .....	34
MultiFrame parameter .....	34
SingleFrame parameter .....	34
Acquisition Mode parameter .....	34
acquisition process .....	47
Acquisition Start command .....	34
Acquisition Stop command .....	34
adjusting Black Level .....	66
any edge .....	38

### B

back panel .....	27
Bayer GB 8/10/12 .....	63
Black Level correction .....	66
Black-Level adjustment .....	66
Black-level signal .....	67
block diagram .....	21

### C

camera control .....	99
Camera Link connector .....	27, 28
camera ON&OFF .....	91
Camera Scan window .....	99
camera's pixel formats .....	63
camera's temperature, parameters .....	85
CC1 .....	36
CC1 Trigger .....	41
circuit .....	32
communication setting .....	97
Configurator .....	26
Configurator execution .....	99



Configurator Plus window .....	101
connector of Camera Link .....	28
Continuous parameter .....	34
controlling cameras.....	99
controlling parameters .....	99
correction of Black Level .....	66

**D**

Defective Pixel Map download.....	101
Device Maintenance window.....	101
DeviceProperty window .....	100
diagram.....	21
dimension.....	23
downloading the application.....	26
downloading the Configurator .....	26
DSNU data, generation.....	71

**E**

Exposure Mode	
Timed .....	36
TriggerWidth .....	36
Exposure Mode parameter .....	36

**F**

falling edge.....	38
FFC .....	75
Flat Field Correction data, generation.....	75
FPGA file upgrade .....	101
frame acquisition process .....	47
Free-run .....	37

**G**

gain value, setting.....	66
generating data of Flat Field correction .....	75

**H**

hardware trigger signal.....	42
Hirose.....	30
Hirose 4-pin .....	31
Hirose 6-pin .....	30

**I**

image-correction sequence .....	67
inputting information of user's choice .....	91

**L**

LED status.....	85
level high.....	38
level low .....	38
Line0.....	36

**M**

Mating .....	30, 31
MCU file upgrade.....	101
mechanical dimension.....	23
Mono 8/10/12.....	63
MultiFrame parameter.....	34
Multi-ROI, determination.....	58

**O**

offset to pixel.....	66
offset value, setting.....	66
OffsetX.....	53
OffsetY.....	53
Optical Black Correction.....	66
order of image correction .....	67
order of signal processing .....	67
order of signals.....	52
overlapped exposure.....	47

**P**

parameter control.....	99
pixel formats.....	63
preface.....	3, 6
PRNU.....	73

**Q**

QE.....	22
quantum efficiency.....	22

**R**

reset physically.....	91
rising edge .....	38
ROI.....	53
ROI-origin position.....	54
ROI-size setting.....	54

**S**

schematic diagram .....32

SDR connector .....28

sequence of image correction .....67

sequence of signal processing.....67

sequence of signals .....52

serial communication setting .....97

signal processing .....52

signal-processing sequence .....67

signals' order .....52

signals' sequence .....52

SingleFrame parameter .....34

Software .....36

specification .....20

spectral sensitivity .....22

strobe output .....32

**T**

tilt .....26

Timed .....36

Timer0Active .....36

trigger input .....32

Trigger Mode

off .....35

on .....35

Trigger Signals .....36

Trigger Source

CC1 .....36

Line0 .....36

Software .....36

Timer0Active .....36

UserOutput0 .....36

Trigger Source parameter .....36

TriggerWidth .....36

TriggerWidth mode .....45

**U**

upgrading FPGA files .....101

upgrading MCU files .....101

upgrading XML files .....101

upgrading files .....101

UserOutput0 .....36

**X**

XML file upgrade .....	101	Geometry_1X4_1Y.....	62
XML parameter		Geometry_1X8_1Y.....	62
Analog Control.....	66, 69	GreyDiagonalRamp.....	86
AnalogControl.....	65	GreyDiagonalRampMoving.....	86
AnyEdge.....	83	GreyHorizontalRamp.....	86
Average.....	59	Height.....	54
BalanceRatio.....	65	HeightMax.....	54
BalanceRatioSelector.....	65	ImageFormatControl.....	54, 59, 63, 69, 86, 89, 90
BalanceWhiteAuto.....	65	Input.....	80
BinningHorizontal.....	59	LevelHigh.....	83
BinningHorizontalMode.....	59	LevelLow.....	83
BinningSelector.....	59	Line 0.....	80
BinningVertical.....	59	Line 1.....	80
BinningVerticalMode		Line0.....	83
Average.....	59	LineInverter.....	80
Sum.....	59	LineMode.....	80
BlackLevel.....	69	LineSelector.....	80
BlackLevelOffset.....	69	LineSource.....	80
BlackLevelSelector.....	69	MultiRoiControl.....	56
CC1.....	83	MultiRoiHeight.....	56
CounterAndTimeControl.....	83	MultiRoiMode.....	56
DataRoiControl.....	64	MultiRoiOffsetX.....	56
Debounce Time.....	82	MultiRoiOffsetY.....	56
DebounceTime.....	80	MultiRoiSelector.....	56
Device Reset.....	91	MultiRoiStatus.....	56
DeviceControl.....	85, 91	MultiRoiValid.....	56
DeviceLinkThroughputLimit.....	91	MultiRoiWidth.....	56
DeviceTapGeometry.....	62	OffsetX.....	54
DeviceTemperature.....	85	OffsetY.....	54
DeviceTemperatureSelector.....	85	OpticalBlackCorrection.....	69
DeviceUserID.....	91	Output.....	80
DigitalOControl.....	80, 82	PixelFormat.....	63
EventNotification.....	79	PRNU.....	73
EventSelector.....	79	PRNUDataGenerate.....	73
ExposureActive.....	80, 83	PRNUDataLoad.....	73
FallingEdge.....	83	PRNUDataSave.....	73
FanOperationMode.....	84	PRNUDataSelector.....	73
FanSpeed.....	84	ReverseX.....	89, 90
Flat Field Data Selector.....	78	RisingEdge.....	83
FlatFieldControl.....	77	RoiHeight.....	64
FlatFieldCorrection.....	77	RoiOffsetX.....	64
FlatFieldDataGenerate.....	77	RoiOffsetY.....	64
FlatFieldDataLoad.....	77	RoiSelector.....	64
FlatFieldDataSave.....	77	RoiWidth.....	64
FlatFieldDataSelector.....	77	SensorHeight.....	54
FlatFieldTargetLevel.....	77	SensorSpecific.....	86
FlatFieldTargetSelector.....	77	SensorWidth.....	54
FrameActive.....	80, 83	SequencerConfigurationMode.....	94
Gain.....	66	SequencerControl.....	94
GainSelector.....	66	SequencerFeatureEnable.....	94
Geometry_1X10_1Y.....	62	SequencerFeatureSelector.....	94
Geometry_1X2_1Y.....	62	SequencerMode.....	94
		SequencerSetActive.....	94
		SequencerSetCount.....	94
		SequencerSetSelector.....	94
		Sum.....	59
		TargetTemperature.....	84
		TestPattern.....	86

Timer0Active.....	80	UserDefault .....	92
TimerDelay .....	83	UserOutput0.....	80
TimerDuration .....	83	UserOutputValue .....	80
TimerReset .....	83	UserSet1 .....	92
TimerTriggerActivation.....	83	UserSet2.....	92
TimerTriggerSource.....	83	UserSetControl.....	92
Timestamp.....	79	UserSetLoad .....	92
TimestampIncrement.....	79	UserSetSave.....	92
TimestampLatch .....	79	UserSetSelector.....	92
TimestampLatchValue .....	79	White Balance Auto.....	64
TimestampReset .....	79	Width.....	54
TimestampResetValue .....	79	WidthMax .....	54
TransportLayerControl.....	62		





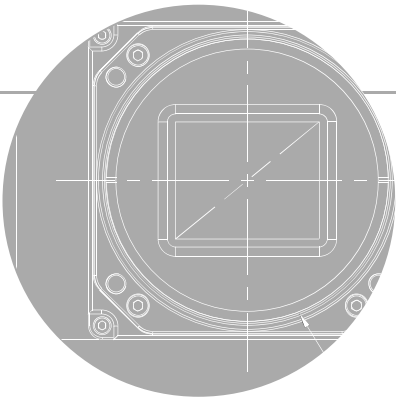
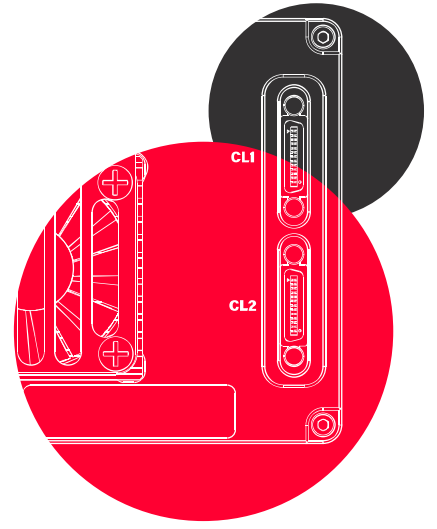
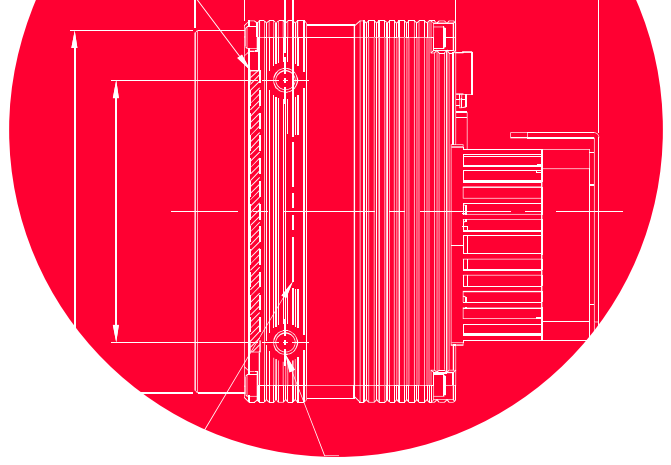

## Vieworks Co., Ltd.

41-3, Burim-ro, 170beon-gil,  
Dongan-gu, Anyang-si, Gyeonggi-do  
14055 Republic of Korea

Tel: +82-70-7011-6161

Fax: +82-31-386-8631

<http://vision.vieworks.com>

[vision@vieworks.com](mailto:vision@vieworks.com)