

VT series

User Manual

English

VT-9K5X2-H550I-256

CoaPress[®]

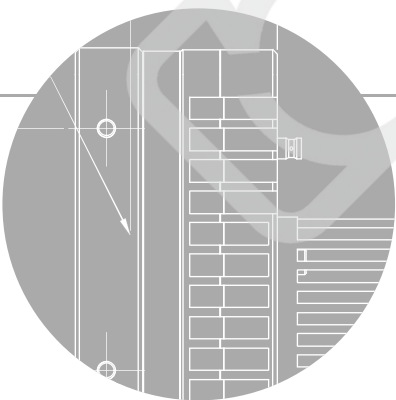

VIEWWORKS

Preface

No part of this manual may either be copied, reproduced, translated, or published in any form or by any means (electronic, mechanical, photocopying, or otherwise) without the express written permission of Vieworks, Co., Ltd. (hereinafter 'Vieworks').

This manual may include the website links to companies other than Vieworks. Vieworks is not responsible for any of these links. The copyrights of the materials mentioned herein are owned by each respective author.

Although Vieworks made every effort to ensure the accuracy of this document, it assumes no responsibility for errors or omissions that may appear herein. The figures in this manual may differ depending on the version of the product or operating system, or the way how it runs. Information in this manual is subject to change without notice.

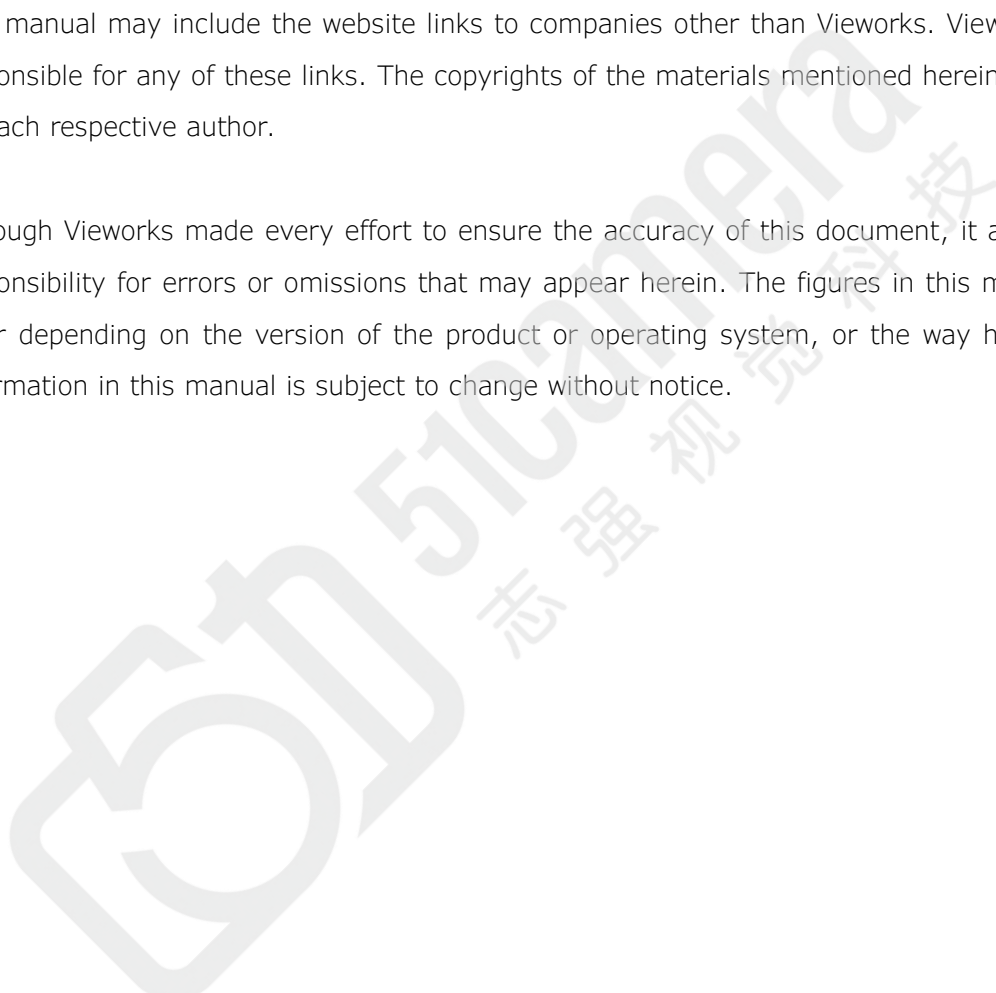

Before Using This Product

Thank you for choosing VT-9K5X2™.

- Make sure to read this manual before using the product.
- Make sure to check whatever a professional engineer has finished installation and configuration.
- Make sure to keep this manual at hand as a reference while using the product.
- This manual assumes that you have expertise in how to use an industrial camera.

The Series

This manual is intended for users of the following products:

- VT-9K5X2-H550I-256

About This Manual

This manual is intended for VT-9K5X2™ camera users. It is recommended to refer to the Frame Grabber's User Manual of yours, with this manual.

Convention in This Manual

For better understanding, the following conventions are used throughout the manual.

Names and Fonts

The names and fonts of user interfaces are used as follows:

- The menu and icon names in this manual are used as displayed in the product.
- The menu and icon names are marked in this font.
- Button or keyboard key names are marked in this font.

Warning, Caution, and Note

This manual shows warnings, cautions, and notes with the following figures:

**Warning!**

This indicates that you need to follow this message for your safety and to prevent the product from damage.

**Caution!**

This indicates that you need to follow this message to prevent data from being lost or corrupted.

**Note:**

This indicates that this message provides additional information.

Definition of Terms

For clarity, this manual defines some terms as follows:

Term	Definition
Preface	The introductory part preceding the Table of Contents in this manual
Application	A program that performs a particular task or set of tasks
Vieworks Imaging Solution	Indicates the control application provided with the product together by Vieworks
VIS	Vieworks Imaging Solution
Dual Band	Indicates that the structure of the sensor in this product that operates by dividing into two bands unlike other sensors

Revision History

This document has the revision history as follows:

Version	Date	Description
1.0	2023-08-18	Initial Release

Contents

Chapter 1. Precautions	15
Chapter 2. Warranty	17
Chapter 3. Compliance & Certifications	18
3.1 FCC Compliance.....	18
3.2 CE : DoC.....	18
3.3 KC	18
Chapter 4. Package Components.....	19
Chapter 5. Product Specifications.....	20
5.1 Overview.....	20
5.2 Specifications	21
5.3 Camera Block Diagram	22
5.4 Quantum Efficiency.....	23
5.5 Mechanical Specification	24
5.5.1 Camera Mounting and Heat Dissipation	25
Chapter 6. Connecting the Camera.....	26
6.1 Precaution to Center the Image Sensor	27
6.2 Installing Vieworks Imaging Solution	27
Chapter 7. Camera Interface.....	28
7.1 General Description.....	28
7.2 CoaXPress Connector	29
7.2.1 Micro-BNC Connector.....	29
7.3 Power Input Receptacle.....	30
7.4 Control I/O Receptacle	31
7.5 Trigger/Strobe Circuit.....	32
Chapter 8. Acquisition Control.....	33
8.1 Acquisition Start/Stop Commands and Acquisition Mode.....	33
8.2 Line Start Trigger	34
8.2.1 Trigger Mode	34

8.2.2	Using an External/CoaXPress Trigger Signal	37
8.2.3	Trigger Multiplier/Divider.....	38
8.3	Maximum Allowed Line Rate.....	40
8.4	Recommended Steps to Correct	41
Chapter 9. Camera Features.....		42
9.1	Device Scan Type	42
9.2	TDI Stages.....	43
9.3	Scan Direction.....	44
9.4	Region of Interest	45
9.5	Binning.....	47
9.6	Pixel Format.....	48
9.7	Data ROI	49
9.8	Dual Band(HDR)	50
9.9	Gain and Black Level	55
9.10	Optical Black Clamp.....	57
9.11	Optical Black Clamp Weight.....	57
9.12	LUT.....	58
9.13	Dark Signal Non-uniformity Correction.....	60
9.13.1	Generating and Saving User DSNU Correction Values.....	61
9.14	Photo Response Non-uniformity Correction	62
9.14.1	Generating and Saving User PRNU Correction Values.....	63
9.15	FPN Coefficients Control	64
9.16	CXP Link Configuration.....	65
9.17	Digital I/O Control	66
9.18	Debounce.....	68
9.19	Temperature Monitor.....	69
9.20	Status LED.....	69
9.21	Test Pattern	70
9.22	Reverse X.....	73
9.23	Counter Control	74
9.24	Timer Control	76

9.25	Device User ID	77
9.26	Device Reset	77
9.27	Field Upgrade	78
9.28	User Set Control	78
Chapter 10. Troubleshooting.....		80
Appendix A. Field Upgrade.....		81
Appendix B. LUT Download		82
B.1	Gamma Graph Download.....	82
B.2	CSV File Download	84
Appendix C. Index		86

Tables

Table 5-1	Specifications of VT-9K5X2.....	21
Table 7-1	Channel Assignments for Micro-BNC Connector	29
Table 7-2	Pin Configurations for Power Input Receptacle	30
Table 7-3	Pin Configurations for Control Receptacle	31
Table 8-1	XML Parameters related to Trigger Multiplier/Divider Mode	39
Table 8-2	Maximum Allowed Line Rates (8 bit)	40
Table 9-1	XML Parameters related to Device Scan Type	42
Table 9-2	XML Parameters related to Device Scan Type	42
Table 9-3	Maximum Allowed Frame Rates.....	42
Table 9-4	The number of available TDI Stages per each band.....	43
Table 9-5	XML Parameters related to Scan Direction	44
Table 9-6	XML Parameters related to ROI	45
Table 9-7	XML Parameters related to Binning	47
Table 9-8	XML Parameter related to Pixel Format	48
Table 9-9	Pixel Format Values	48
Table 9-10	XML Parameters related to Data ROI.....	49
Table 9-11	XML Parameters related to Gain and Black Level	56
Table 9-12	XML Parameters related to Optical Black Clamp	57
Table 9-13	XML Parameters related to Optical Black Clamp Weight.....	57
Table 9-14	XML Parameters related to LUT	59
Table 9-15	XML Parameters related to DSNU	60
Table 9-16	XML Parameters related to PRNU	62
Table 9-17	XML Parameters related to FPN Coefficients Control	64
Table 9-18	XML Parameters related to CXP Link Configuration.....	65

Table 9-19	XML Parameters related to Digital I/O Control	66
Table 9-20	XML Parameters related to Device Temperature.....	69
Table 9-21	Status LED	69
Table 9-22	XML Parameter related to Test Pattern.....	70
Table 9-23	XML Parameter related to Reverse X	73
Table 9-24	XML Parameters related to Counter Control (1).....	74
Table 9-25	XML Parameters related to Counter Control (2).....	75
Table 9-26	XML Parameters related to Timer Control.....	76
Table 9-27	XML Parameter related to Device User ID.....	77
Table 9-28	XML Parameter related to Device Reset.....	77
Table 9-29	XML Parameters related to User Set Control.....	78

Figures

Figure 5-1	Camera Block Diagram.....	22
Figure 5-2	Quantum Efficiency	23
Figure 5-3	VT-9K5X2 Mechanical Dimension	24
Figure 7-1	VT-9K5X2 Cameras' Back Panel	28
Figure 7-2	Micro-BNC Connector	29
Figure 7-3	Pin Assignments for Power Input Receptacle	30
Figure 7-4	Pin Assignments for Control Receptacle	31
Figure 7-5	Trigger/Strobe Circuit	32
Figure 8-1	Trigger Mode = Off	35
Figure 8-2	Trigger Mode = On	36
Figure 8-3	Trigger Ratio = 0.5	38
Figure 9-1	Scan Direction.....	44
Figure 9-2	Region of Interest.....	45
Figure 9-3	Sensor Binning	47
Figure 9-4	Effective Data ROI.....	49
Figure 9-5	The Dual Band structure of the sensor	50
Figure 9-6	Errors depending on the directions of scan	51
Figure 9-7	Spatial Correction	52
Figure 9-8	LUT Block	58
Figure 9-9	LUT at Gamma 0.5.....	59
Figure 9-10	CXP Link Configuration	65
Figure 9-11	User Output	67
Figure 9-12	Exposure Active Signal.....	67
Figure 9-13	Debounce	68

Figure 9-14	Grey Horizontal Ramp	70
Figure 9-15	Grey Diagonal Ramp	71
Figure 9-16	Grey Diagonal Ramp Moving	71
Figure 9-17	Sensor Specific	72
Figure 9-18	Original Image	73
Figure 9-19	Reverse X Image	73
Figure 9-20	Timer Signal	77
Figure 9-21	User Set Control	79

Chapter 1. Precautions

General



Caution!

- Do not drop, disassemble, repair or alter the device. Doing so may damage the camera electronics and cause an electric shock.
 - Do not let children touch the device without supervision.
 - Stop using the device and contact the nearest dealer or manufacturer for technical assistance if liquid such as water, drinks or chemicals gets into the device.
 - Do not touch the device with wet hands. Doing so may cause an electric shock.
 - Make sure that the temperature of the camera does not exceed the temperature range specified in 5.2 Specifications. Otherwise the device may be damaged by extreme temperature.
-

Installation and Maintenance



Caution!

- Do not install in dusty or dirty areas - or near an air conditioner or heater to reduce the risk of damage to the device.
 - Avoid installing and operating in an extreme environment where vibration, heat, humidity, dust, strong magnetic fields, explosive/corrosive mists or gases are present.
 - Do not apply excessive vibration and shock to the device. This may damage the device.
 - Avoid direct exposure to a high intensity light source. This may damage the image sensor.
 - Do not install the device under unstable lighting conditions. Severe lighting change will affect the quality of the image produced by the device.
 - Do not use solvents or thinners to clean the surface of the device. This can damage the surface finish.
-

Power Supply



Caution!

- Applying incorrect power can damage the camera. If the voltage applied to the camera is greater or less than the camera's nominal voltage, the camera may be damaged or operate erratically. Please refer to 5.2 Specifications for the camera's nominal voltage.
 - ※ Vieworks Co., Ltd. does NOT provide power supplies with the devices.
 - Make sure the power is turned off before connecting the power cord to the camera. Otherwise, damage to the camera may result.
-

Cleaning the Sensor Surface

Avoid cleaning the surface of the camera's sensor if possible. If you have dust or foreign matter on the sensor surface that will not blow off, use a soft lint free cotton bud dampened with a small quantity of high quality lens cleaner. Because electrostatic discharge (ESD) can damage the sensor, you must use a cloth (e.g. cotton) that will not generate static during cleaning.



Avoid dust or foreign matter on the sensor surface.

The camera is shipped with a protective plastic seal on the camera front. To prevent collecting dust or foreign matter on the camera sensor, make sure that you always put the protective seal in place when there is no lens mounted on the camera. In addition, make sure to always point the camera downward when there is no protective seal on the camera front or no lens mounted.

Procedures for Cleaning the Sensor

If you have dust or foreign matter on the sensor surface, follow the procedures below to wipe off.

1. Remove a contaminant by using an ionizing air gun.
If this step does not remove the contaminant, proceed to the next step.
2. Clean the contaminant on the sensor using one drop of lens cleaner on a non-fluffy cotton bud.
3. Wipe the cotton bud gently in only one direction (either left to right or right to left). Avoid wiping back and forth with the same cotton bud in order to ensure that the contaminants are removed and not simply transferred to a new location on the sensor surface.
4. Mount a lens, set the lens at a smaller aperture (e.g. F8), and then acquire images under bright lighting conditions. Check the images on the monitor for dark spots or stripes caused by the contaminant. Repeat the steps above until there is no contaminant present.



Caution!

If the sensor is damaged due to electrostatic discharge or the sensor surface is scratched during cleaning, the warranty is void.

Chapter 2. Warranty

Do not open the housing of the camera. The warranty becomes void if the housing is opened.
For information about the warranty, please contact your local dealer or factory representative.



Chapter 3. Compliance & Certifications

3.1 FCC Compliance

This equipment has been tested and found to comply with the limits for a Class A digital device, pursuant to part 15 of the FCC Rules. These limits are designed to provide reasonable protection against harmful interference when the equipment is operated in a commercial environment. This equipment generates, uses, and can radiate radio frequency energy and, if not installed and used in accordance with the instruction manual, may cause harmful interference to radio communications. Operation of this equipment in a residential area is likely to cause harmful interference in which case the user will be required to correct the interference at his own expenses.

3.2 CE : DoC

EMC Directive 2014/30/EU

EN 55032:2012 (Class A), EN 55024:2010

Class A

3.3 KC

KCC Statement

Type	Description
Class A (Broadcasting Communication Device for Office Use)	This device obtained EMC registration for office use (Class A), and may be used in places other than home. Sellers and/or users need to take note of this.

Chapter 4. Package Components

Package Components



VT-9K5X2-H550I-256 with M58 mount

Chapter 5. Product Specifications

5.1 Overview

The VT-9K5X2-H550I-256 camera, the new Time Delayed Integration (TDI) camera with a Back-Side Illuminated (BSI) image sensor by charge domain CMOS technology, provides faster line rates and higher sensitivity than existing TDI cameras. With the state-of-the-art BSI sensor from Gpixel, the camera acquires images of 9k resolution with 256× higher sensitivity, and for higher than that, the camera also supports the HDR feature using both photosensitive bands, 256 stages and 32 stages respectively. Featured with high speed and high sensitivity, the camera is ideal for demanding applications such as flat panel inspection, wafer inspection, printed circuit board inspection, and high-performance document scanning.

Main Features

- 9k TDI, BSI(Back-Side Illuminated), Charge-domain CMOS
- CoaXPRESS Interface up to 543 kHz at 50 Gbps using 4 CH
- Bidirectional Operation with up to 256 TDI Stages in a Single Band, or 32 TDI Stages in a Dual Band
- Advanced DSNU and PRNU Correction
- Strobe Output Control
- GenICam Compatible - XML based Control

Applications

- Semiconductor Inspection
- Printed Circuit Board Inspection
- Flat Panel Display Inspection
- Fluorescence Imaging

5.2 Specifications

Technical specifications for the VT-9K5X2 cameras are as follows.

Specification	Single Band (No HDR)	Dual Band (HDR)
Active Image(H × V)	9056 × 256	9056 × (256 + 32)
Sensor Type	High Speed CMOS TDI Image Sensor	
Sensor	Gpixel GLT5009BSI	
Sensor Size (diagonal)	45.36 mm × 1.28 mm	45.36 mm × (1.28 + 0.16) mm
Pixel Size	5.0 μm × 5.0 μm	
Interface	CoaXPress 2.0 (CXP-12, 4CH)	
Pixel Data Format	Mono 8/10/12 bit	Mono 8/10 bit
TDI Stage	4/8/16/32/64/96/128/160/192/224/240/248/252/256	
	OFF	2/4/8/16/24/28/30/32
Trigger Synchronization	Free-Run, External or CoaXPress 2.0	
Min. Line Rate	30 kHz (8/10/12 bit)	
Max. Line Rate	543 kHz (8 bit) / 435 kHz (10 bit) / 300 kHz (12 bit)	
Throughput	4.9 Gpixels	
Gamma Correction	User Defined LUT (Look Up Table)	
Black Level Control	-255 ~ 255 at 8 bit	
Gain Control	Analog Gain: ×2.0 ~ ×8.0 / Digital Gain: ×1.0 ~ ×32.0	
Power	External	12 ~ 24 VDC
	Dissipation	Typ. 25.2 W
	PoCXP	24 VDC, Minimum of Two PoCXP Cables Required
Environmental	Ambient Operating: 0°C ~ 40°C (Housing: 10°C ~ 55°C), Storage: -40°C ~ 70°C	
Compliance	CE, FCC, KC	
Mechanical / Weight	90 mm × 90 mm × 80 mm, 800 g	
API SDK	Vieworks Imaging Solution 7.x	

Table 5-1 Specifications of VT-9K5X2

5.3 Camera Block Diagram

VL series consists of three printed circuit boards (PCB), and its block diagram is shown below.

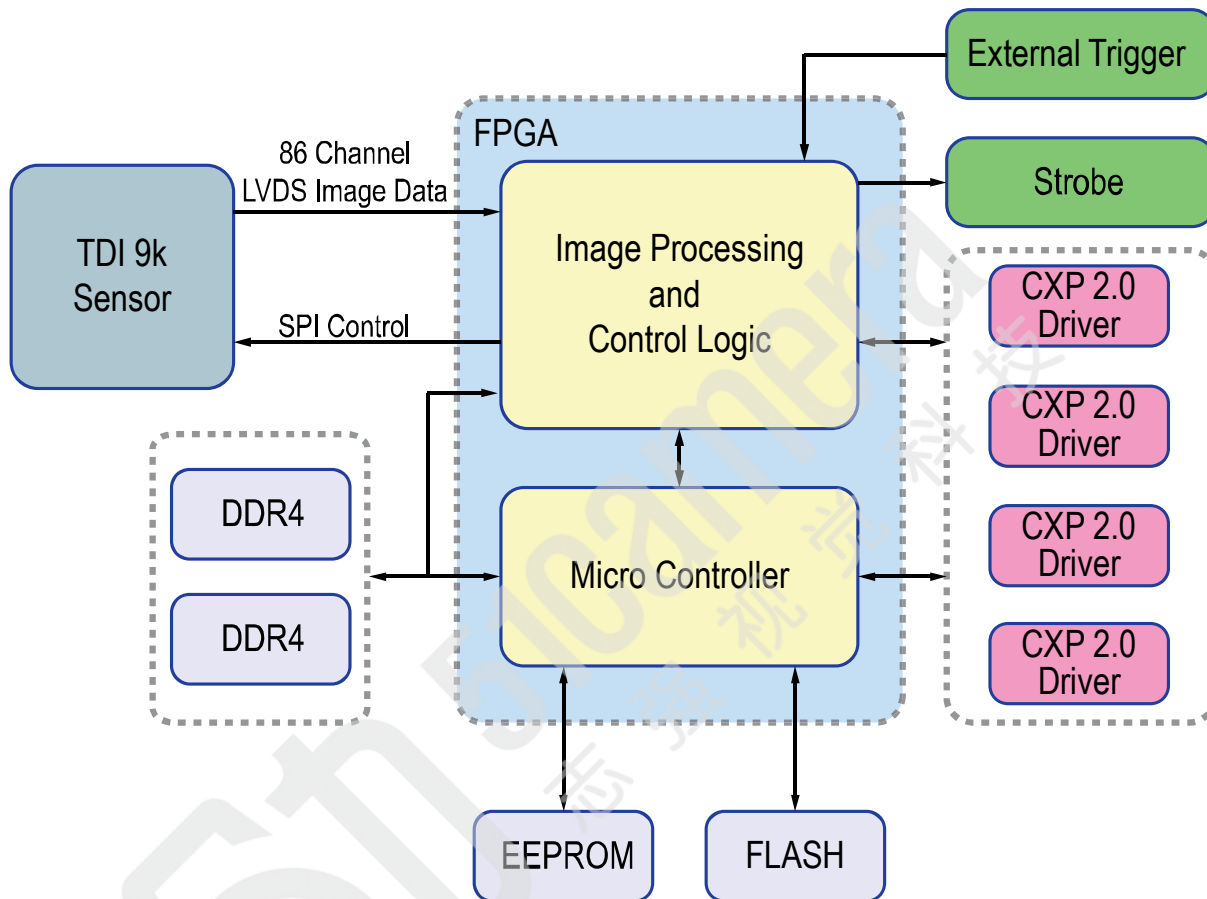

Figure 5-1 Camera Block Diagram

5.4 Quantum Efficiency

The following graphs show the quantum efficiency for the VT-9K5X2.

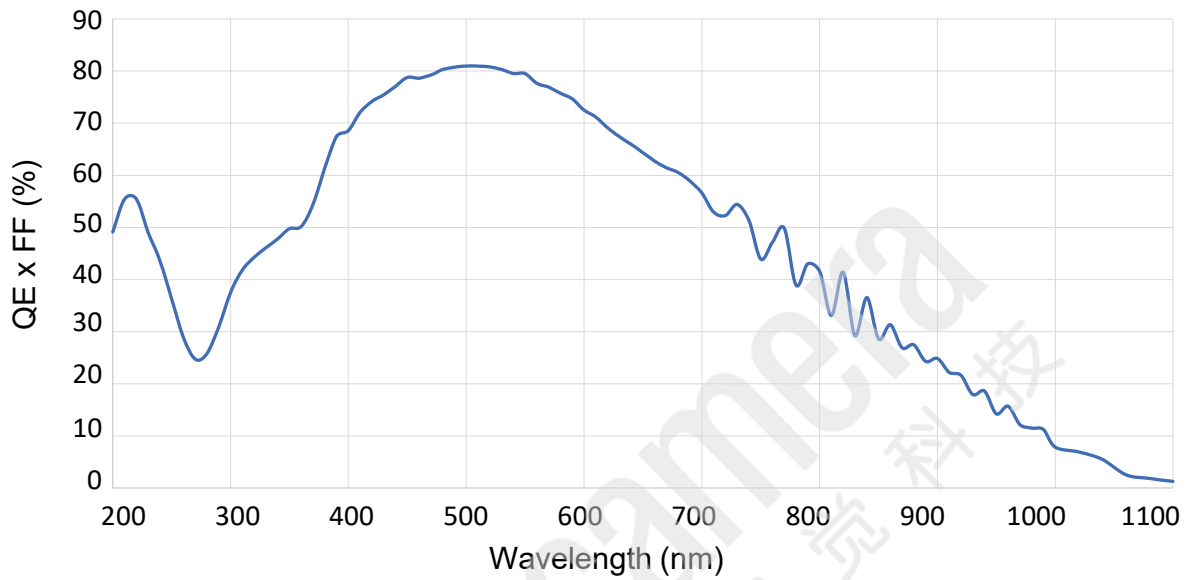

Figure 5-2 Quantum Efficiency

5.5 Mechanical Specification

The camera dimensions in millimeters are shown in the following figure.

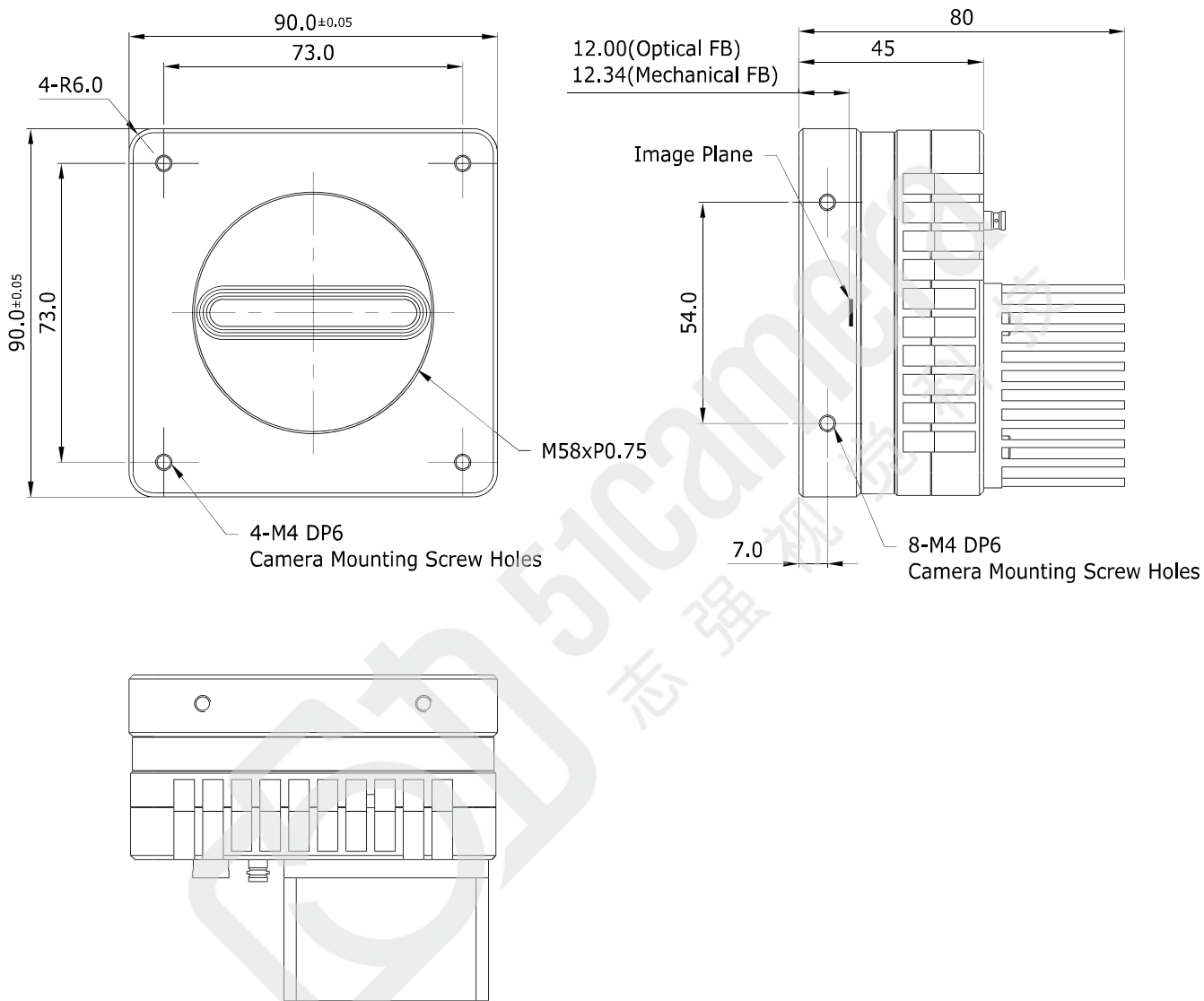

Figure 5-3 VT-9K5X2 Mechanical Dimension

5.5.1 Camera Mounting and Heat Dissipation

You must mount the camera on a heat dissipation structure to maintain the temperature of the camera housing at 50°C or less. Given the low power consumption of the VL series camera, its housing temperature during operation will generally stay within the specified limits. However, overheating can occur if heat dissipation is restricted or if the camera is mounted on a severe environment. It is recommended to follow the general guidelines below when you mount the camera.

- In all cases, you should monitor the temperature of the camera housing and make sure that the temperature does not exceed 50°C. You can monitor the internal temperature of the camera by using the Device Temperature parameter.
- If your camera is mounted on a metal component in your system, this may provide sufficient heat dissipation.

Chapter 6. Connecting the Camera

The following instructions assume that you have installed a CoaXPress 2.0 Frame Grabber (hereinafter 'CXP-12 Frame Grabber') in your computer including related software. The procedure below also assumes that you may attempt to configure a link between a camera and CXP-12 Frame Grabber by using four coax cables. For more detailed information, refer to your CXP-12 Frame Grabber User Manual.

To connect the camera to your PC, follow the steps below.

1. Make sure that the power supply is not connected to the camera and your computer is turned off.
2. Plug one end of a coax cable into the CH1 of the CXP connector on the camera and the other end of the coax cable into the CH1 of the CXP-12 Frame Grabber in your computer. Then, connect the CH2, CH3 and CH4 of the CXP connector on the camera to the CH2, CH3 and CH4 of the CXP-12 Frame Grabber respectively using the other three coax cables.

- Connect the plug of the power adapter to the power input receptacle on the camera.
- Plug the power adapter into a working electrical outlet.

The power adapter isn't necessary to be connected if using Power over CoaXPress.



Caution!

To power a camera via PoCXP Frame Grabber, you must connect both the CH1 and CH2 channels of the camera to their respective connectors on the CXP-12 Frame Grabber.

3. Verify all the cable connections are secure.

6.1 Precaution to Center the Image Sensor

- Users do not need to center the image sensor as it is adjusted as factory default settings.
- When you need to adjust the center of the image sensor, please contact your local dealer or the manufacturer for technical assistance.

6.2 Installing Vieworks Imaging Solution

You can download the Vieworks Imaging Solution at <http://vision.vieworks.com>. You should perform the software installation first and then the hardware installation.

Chapter 7. Camera Interface

7.1 General Description

As shown in the following figure, three types of connectors and a status indicator LED are located on the back of the camera and have the functions as follows:

- | | |
|---------------------------------|---|
| ① CoaXPress Connector: | transmits video data and controls the camera. |
| ② Status LED: | displays power status and operation mode. |
| ③ 6-pin Power Input Receptacle: | supplies power to the camera. |
| ④ 4-pin Control Receptacle: | inputs external trigger signals and outputs strobe signals. |

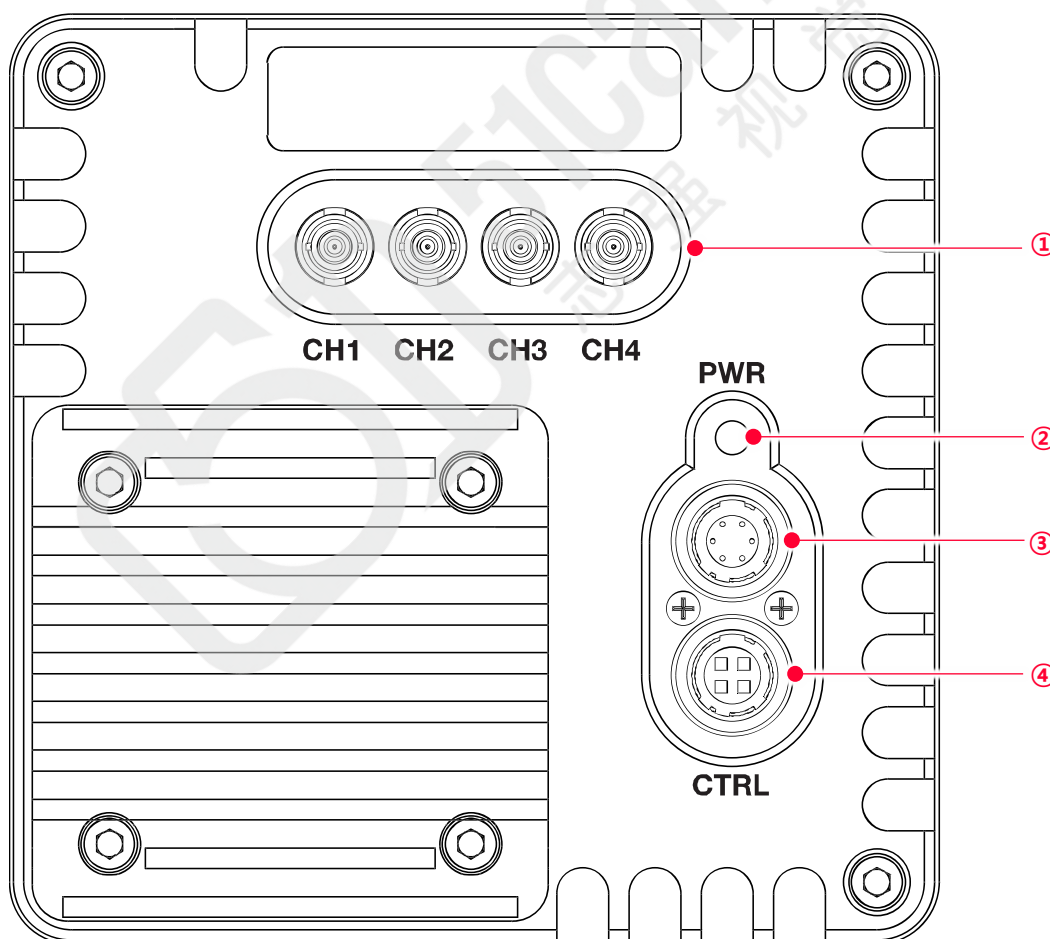

Figure 7-1 VT-9K5X2 Cameras' Back Panel

7.2 CoaXPress Connector

CoaXPress protocol includes an automatic link detection mechanism (Plug and Play) to correctly detect the camera to the CXP-12 Frame Grabber connection. The connection between the camera and CXP-12 Frame Grabber uses a coax (also known as 'coaxial') cable and provides up to 12.5 Gbps bit rate per cable.

7.2.1 Micro-BNC Connector

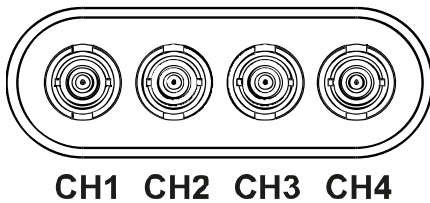

Figure 7-2 Micro-BNC Connector

The CoaXPress connector on the VT-9K5X2 cameras comply with the CoaXPress standard and the following table shows the channel assignments.

Channel	Max. Bit Rate per Coax	Type	PoCXP Compliant
CH1	12.5 Gbps	Master Connection	Yes
CH2	12.5 Gbps	Extension Connection	Yes
CH3	12.5 Gbps	Extension Connection	No
CH4	12.5 Gbps	Extension Connection	No

Table 7-1 Channel Assignments for Micro-BNC Connector



Note:

When you connect a camera to a CXP-12 Frame Grabber using coax cables, make sure to connect the cables to their correct channels. If you connect the CH1 of the CXP connector on the camera to a channel other than CH1 of the CXP-12 Frame Grabber, the camera may not transmit images properly or the communication between the computer and camera may fail.

7.3 Power Input Receptacle

The power input receptacle is a Hirose 6-pin connector (part # HR10A-7R-6PB). The pin assignments and configurations are as follows:

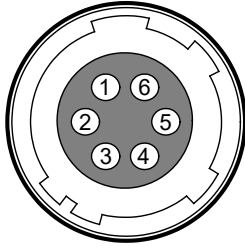

Figure 7-3 Pin Assignments for Power Input Receptacle

Pin Number	Signal	Type	Description
1, 2, 3	+ 12 VDC	Input	DC Power Input
4, 5, 6	DC Ground	Input	DC Ground

Table 7-2 Pin Configurations for Power Input Receptacle



Note:

- A recommended mating connector for the Hirose 6-pin connector is the Hirose 6-pin plug (part # HR10A-7P-6S) or the equivalent.
- It is recommended that you use the power adapter, which has at least 3 A current output at 12 VDC \pm 10% voltage output (You need to purchase a power adapter separately.).

Precaution for Power Input



Caution!

- Make sure the power is turned off before connecting the power cord to the camera. Otherwise, damage to the camera may result.
- If the voltage applied to the camera is greater than specified in the specifications, damage to the camera may result.
- Make sure not to use the PoCXP and the power adapter together.

7.4 Control I/O Receptacle

The control I/O receptacle is a Hirose 4-pin connector (part # HR10A-7R-4S) and consists of an external trigger signal input and strobe output ports. The pin assignments and configurations are as follows:

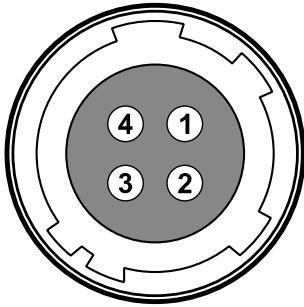

Figure 7-4 Pin Assignments for Control Receptacle

Pin Number	Signal	Type	Description
1	Trigger Input	Input	3.3 V ~ 5.0 V TTL input
2	Scan Direction Input	Input	3.3 V ~ 5.0 V TTL input
3	DC Ground	-	DC Ground
4	Strobe Out	Output	3.3 V TTL Output Output resistance: 47 Ω

Table 7-3 Pin Configurations for Control Receptacle



Note:

A recommended mating connector for the Hirose 4-pin connector is the Hirose 4-pin plug (part # HR10A-7P-4P) or the equivalent.

7.5 Trigger/Strobe Circuit

The following figure shows trigger signal input and TDI direction signal input circuit of the 4-pin connector. Transmitted trigger signal and TDI direction signal is applied to the internal circuit through a CMOS buffer with a good noise margin. The minimum trigger width that can be recognized by the camera is 1 μ s. If transmitted trigger signal is less than 1 μ s, the camera will ignore the trigger signal. An external trigger and TDI direction circuit example is shown below.

The strobe output signal comes out through a 3.3 V output level of Line Driver IC. A pulse width of the signal is synchronized with a Line Start trigger (shutter) of the camera.

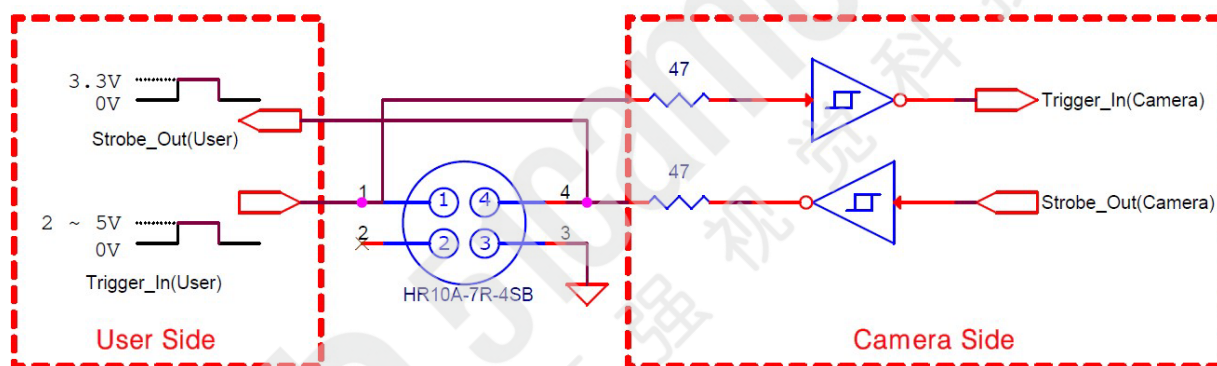

Figure 7-5 Trigger/Strobe Circuit

Chapter 8. Acquisition Control

This chapter provides detailed information about the following elements involved with the image acquisition.

- Acquisition Start/Stop commands and Acquisition Mode parameter
- Line Start trigger
- Line Rate control
- Exposure Mode

8.1 Acquisition Start/Stop Commands and Acquisition Mode

The **Acquisition Start** command prepares the camera to acquire images. The camera cannot acquire images unless an **Acquisition Start** command has first been executed.

Executing an **Acquisition Stop** command terminates the camera's ability to acquire images.

A parameter called the **Acquisition Mode** has a direct bearing on how the **Acquisition Start** command operates. The VT-9K5X2 cameras only support **Continuous** for the **Acquisition Mode** parameter.

The **Acquisition Start** command will remain in effect until you execute the **Acquisition Stop** command. Once an **Acquisition Stop** command has been executed, the camera will not be able to acquire images until a new **Acquisition Start** command is executed.

8.2 Line Start Trigger

The Trigger Selector parameter is used to select a type of trigger and only the Line Start trigger is available on the VT-9K5X2 cameras. The Line Start trigger is used to begin line acquisition. Line Start trigger signals can be generated within the camera or may be applied externally by setting the Trigger Source parameter to Line0 or LinkTrigger0. If a line start trigger signal is applied to the camera, the camera will begin to acquire images.

8.2.1 Trigger Mode

The main parameter associated with the line start trigger is the Trigger Mode parameter. The Trigger Mode parameter for the line start trigger has two available settings: Off and On.

Trigger Mode = Off

When the Trigger Mode parameter is set to Off, the camera will generate all required line start trigger signals internally, and you do not need to apply line start trigger signals to the camera. With the Trigger Mode set to Off, the camera will automatically generate a line start trigger signal whenever it receives an Acquisition Start command. The camera will automatically do this until executing an Acquisition Stop command.



Free-Run

When you set the Trigger Mode parameter to Off, the camera will generate all required trigger signals internally. When the camera is set this way, it will constantly acquire images without any need for triggering by the user. This use case is commonly known as "free-Run".

The rate at which the line start trigger signals are generated may be determined by the camera's Acquisition Line Rate parameter.

- If the parameter is set to a value less than the maximum allowed line rate with the current camera settings, the camera will acquire images at the rate specified by the parameter setting.
- If the parameter is set to a value greater than the maximum allowed line rate with the current camera settings, the camera will acquire images at the maximum allowed line rate.

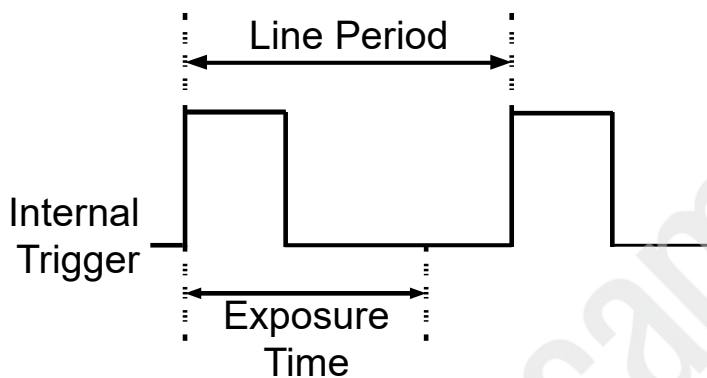

Figure 8-1 Trigger Mode = Off

Trigger Mode = On

When the **Trigger Mode** parameter is set to **On**, you must apply a line start trigger signal to the camera each time you want to begin an image acquisition. The **Trigger Source** parameter specifies the source signal that will act as the line start trigger signal.

The available settings for the **Trigger Source** parameter are:

- **Line0:** You can apply a line start trigger signal to the camera by injecting an externally generated electrical signal (commonly referred to as a hardware or external trigger signal) into the Control I/O Receptacle on the camera. Refer to 7.5 Trigger/Strobe Circuit for more information.
- **LinkTrigger0:** You can apply a line start trigger signal via CH1 of the CXP Frame Grabber. For more information, refer to your CXP Frame Grabber User Manual.

If the **Trigger Source** parameter is set, you must also set the **Trigger Activation** parameter.

The available settings for the **Trigger Activation** parameter are:

- **Rising Edge:** Specifies that a rising edge of the electrical signal will act as the line start trigger.
- **Falling Edge:** Specifies that a falling edge of the electrical signal will act as the line start trigger.
- **Any Edge:** Specifies that both rising and falling edges of the electrical signal will act as the line start trigger.

When the **Trigger Mode** parameter is set to **On**, the camera's line rate can be controlled by manipulating the external trigger signal. At this point, it is important that you do not attempt to trigger images at a rate that is greater than the maximum allowed.

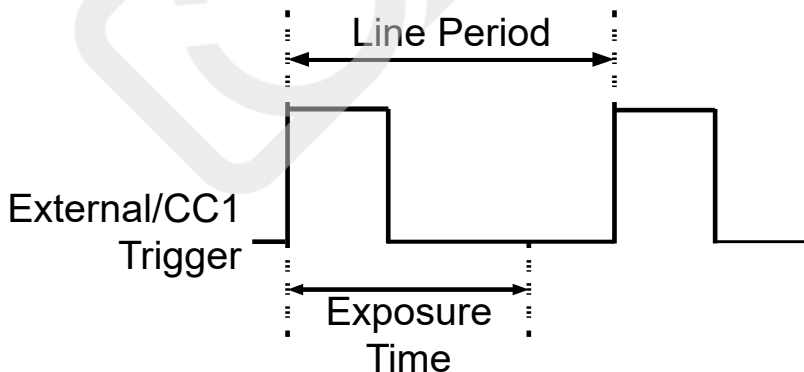

Figure 8-2 Trigger Mode = On

8.2.2 Using an External/CoaXPress Trigger Signal

If the Trigger Mode parameter is set to On and the Trigger Source parameter is set to LinkTrigger0, you must apply an external or CoaXPress trigger signal to the camera to begin image acquisition.

To apply trigger signals via CH1 of the CXP Frame Grabber, you must set the Trigger Source parameter to LinkTrigger0. At that point, each time a proper CoaXPress trigger signal is applied to the camera by using the APIs provided by a CXP Frame Grabber manufacturer, the line start trigger signal will be applied to the camera.

For more information, refer to your CXP Frame Grabber User Manual.

To apply trigger signals via hardware (external), you must set the Trigger Source parameter to Line0. At that point, each time a proper electrical signal is applied to the camera, an occurrence of the line start trigger signal will be recognized by the camera.

A rising edge and/or a falling edge of the external or CoaXPress signal can be used to trigger image acquisition. The Trigger Activation parameter is used to select rising edge and/or falling edge triggering.

When the camera is operating under control of an external or CoaXPress signal, the period of trigger signal will determine the rate at which the camera is acquiring images:

$$\text{Line Rate(Hz)} = \frac{1}{\text{External/CoaXPress signal period in seconds}}$$

For example, if you are operating a camera with an external trigger signal period of 20 μ s (0.00002 s):

So in this case, the line rate is 50 kHz.

8.2.3 Trigger Multiplier/Divider

With the Trigger Multiplier or Trigger Divider, you can modulate the period of the external trigger signal as desired. For example, if you supply the external trigger signal into the camera's I/O receptacle using the conveyor's encoder, the number of output pulses per revolution of the encoder is fixed. In this situation, you can modulate the period of the trigger signal received from the camera on the Trigger Multiplier or the Trigger Divider in the following manner, to match the pitch of the image in vertical direction.

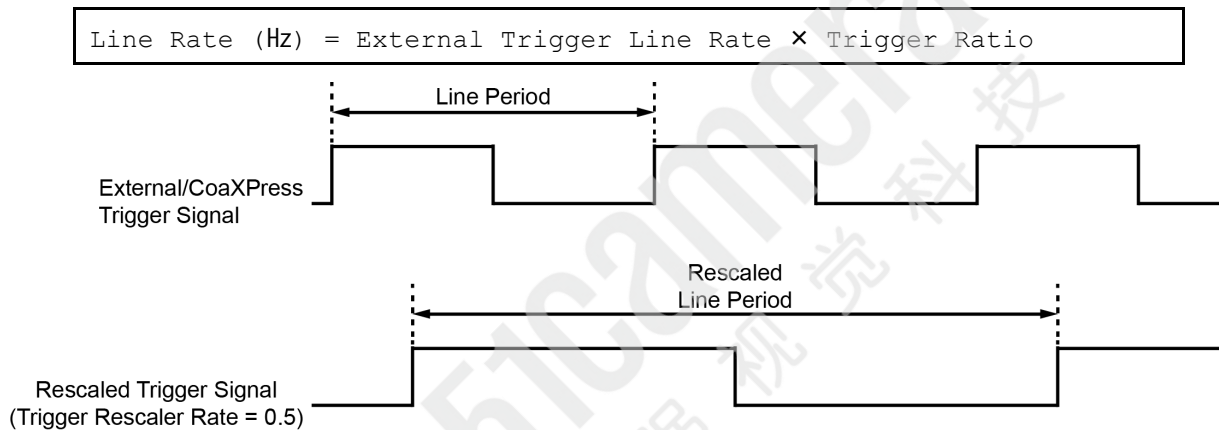

Figure 8-3 Trigger Ratio = 0.5

The XML parameters related to Trigger Multiplier or Trigger Divider are as follows.

XML Parameters	Value	Description
Acquisition Control	Trigger Multiplier	1 - 1024 Sets the trigger rescaler rate for converting trigger signals.
	Trigger Divider	1 - 1024 Sets the trigger rescaler rate for converting trigger signals.
	Trigger Ratio	0.000977 - 1024 Sets the trigger rescaler rate for converting trigger signals.
	TriggerRescaler FilterSize	Sets the rescaler filter factor to decrease the jitter of the external trigger signals.
		SIZE16 Sets the rescaler filter factor to 16.
		SIZE32 Sets the rescaler filter factor to 32.
		SIZE64 Sets the rescaler filter factor to 64.
	SIZE128 Sets the rescaler filter factor to 128.	
	SIZE256 Sets the rescaler filter factor to 256.	
	SIZE512 Sets the rescaler filter factor to 512.	

Table 8-1 XML Parameters related to Trigger Multiplier/Divider Mode



Note:

To apply setting values successfully, it is necessary for Multiplier and Divider to input trigger signals several times at the beginning. Strobe outputs are delayed until the setting is applied well.

8.3 Maximum Allowed Line Rate

In general, the maximum allowed acquisition line rate on the camera may be limited by the following factor:

- The maximum allowed bit rate per cable and the number of CXP Link Configurations
- When the maximum allowed bit rate per cable is set to a high value (e.g., CXP6 supports up to 6.25 Gbps and CXP12 supports up to 12.5 Gbps), it will take less time to transfer acquired images from the camera to the CXP Frame Grabber in your computer.
- When the camera is set for a CXP Link Configuration that uses more channels, it can typically transfer data out of the camera faster. So, if the camera is set for a higher bit rate and number of channels, it will typically have a much higher maximum allowed line rate than when it is set for a lower bit rate and number of channels.

The maximum allowed line rates of the VT-9K5X2 cameras are as follows:

CXP Link Configuration	Maximum Line Rate at Full Resolution
CXP1 × 4	45.25 kHz
CXP2 × 4	90.5 kHz
CXP3 × 4	135.75 kHz
CXP5 × 4	226.25 kHz
CXP6 × 4	271.5 kHz
CXP10 × 4	452.5 kHz
CXP12 × 4	543 kHz

Table 8-2 Maximum Allowed Line Rates (8 bit)

Increasing the Maximum Allowed Line Rate

You may find that you would like to acquire line images at a rate higher than the maximum allowed with the camera's current settings. In this case, you must adjust one or more of the factors that can influence the maximum allowed line rate and then check to see if the maximum allowed line rate has increased.

- The time that it takes to transmit line images out of the camera is the main limiting factor on the line rate. You can decrease the line transmission time (and thus increase the maximum allowed line rate) by doing one or more of the following:
 - Use an 8 bit pixel data format rather than 12 bit pixel format. Images with fewer bits per pixel will take less time to transmit.
 - Use a smaller length of ROI. Decreasing the length of ROI means that the camera has less data to transmit and therefore the transmission time will decrease.
 - Use a CXP Link Configuration with a higher bit rate and number of channels.

8.4 Recommended Steps to Correct

Normally, differences may occur in output images, if sensor-related settings among camera's settings such as pixel format, speed, and the number of Stage are changed. Therefore, it is important to perform the correction in consideration of the camera's settings and environment as needed. Unlike existing VT cameras, VT-9K5X2 additionally supports automatic-adjustment function for black level, **BlackLevelCalibrationAuto**, and a correction function for pixel values depending on temperature changes, **OpticalBlackClampCalibration**, for optimal image quality. Under normal conditions, it is recommended to perform the correction in the following order:

1. Set the pixel format, line rate, and TDI Stage according to the conditions of use.
2. Create a dark environment where no light enters the camera.
3. Execute **BlackLevelCalibrationAuto** while the image is being output.
4. Make the **OpticalBlackClamp** parameter On, and execute **OpticalBlackClampCalibration**.
5. Proceed the DSNU correction.

It is recommended to renew the correction in the following cases, when changing the camera-related settings possible to affect sensor's output conditions:

- When the line rate changes more than 10 kHz
- When a temperature changes more than 7 degrees
- When an analog gain changes
- When a pixel format changes
- When the number of Stages changes

Note:



When using the sensor of VT-9K5X2 on higher line rates than 470 kHz at 8 bit or 240 kHz at 10 bit, horizontal-noise patterns may occur at some line rates due to the sensor's characteristics. Refer to 9.11 Optical Black Clamp Weight for more information.

Chapter 9. Camera Features

9.1 Device Scan Type

The VT-9K5X2 cameras have two different operation modes: **Areascan** and **Linescan**. If the **DeviceControl** parameter is set to **Areascan**, the camera will operate as an area scan camera using the pixel-array as the numbers of Stages selected on **TDI Stage**. This mode is useful for aligning the camera to your target object. If the **DeviceControl** parameter is set to **Linescan**, the camera will operate as a line scan camera.

The commands related to the **DeviceControl** are as follows.

XML Parameters		Value	Description
DeviceControl	DeviceScanType	Areascan	Operates the camera in the Areascan Mode.
		Linescan	Operates the camera in the Linescan mode.

Table 9-1 XML Parameters related to Device Scan Type

On the **Areascan** mode, the XML parameters related to a height size of an images are as follows.

XML Parameters		Value	Description
ImageFormatControl	Height	32 ~ 16384	Sets the Height value in the Areascan mode Available to set in multiples of TDIStages
AcquisitionFrameRate	-	-	Sets the Frame Rate value in the Areascan mode
Exposure Time	-	0.046 ~ 1000 μ s	Sets the Exposure Time value in the Areascan mode

Table 9-2 XML Parameters related to Device Scan Type

The maximum frame rate available to be output on the **Areascan** mode differs depending on the set **TDI Stage** and **Exposure Time**. The maximum **Exposure Time** available to be set is 1,000 μ s at 10 bit, and the maximum frame rate according to **TDI Stage** is as follows.

TDI Stage	Maximum Frame Rate at Full Resolution
256 stage	1,619 fps
128 stage	3,239 fps

Table 9-3 Maximum Allowed Frame Rates

9.2 TDI Stages

In the Linescan mode, the parameters of TDI Stages are used to determine the number of integration stages used by the camera. The sensor of VT-9K5X2 consists of two bands, Band1 and Band2. The cumulative number of Stage of Band1 and Band2 is configurable by setting the TDI Stage and TDI Stage2 parameters. For example, if the TDI Stage parameter of Band1 is set to 256 and the parameter of Band2 is 32, the camera will acquire 2 of images with different sensitivity of 8 times.

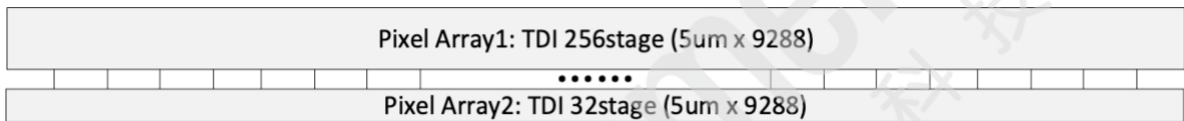

The XML parameter related to setting TDI Stage and the number of TDI Stage available to set per a band are as follows.

Band	The Number of Available TDI Stage
TDIStages (Band1)	4/8/16/32/64/96/128/160/192/224/240/248/252/256
TDIStage2 (Band2)	Off/2/4/8/16/24/28/30/32

Table 9-4 The number of available TDI Stages per each band



Note:

The position where sensor's accumulation starts is as follows according to stage and scan direction:

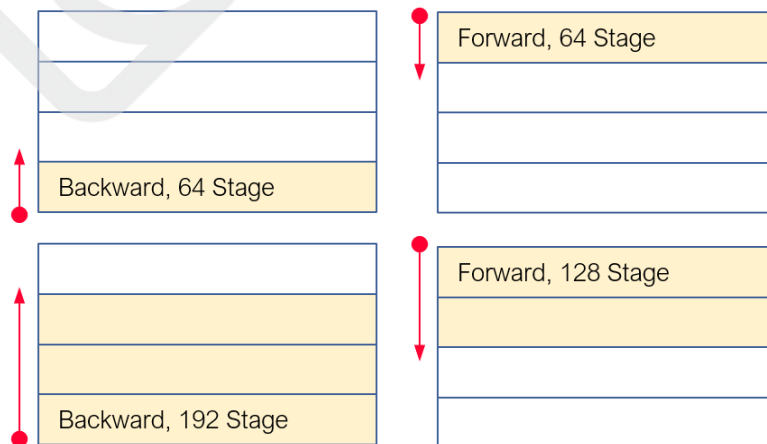

9.3 Scan Direction

In the Linescan mode, the Scan Direction parameter is used to select the image sensor’s scan direction. You need to set the Scan Direction parameter to **Forward** if the object being imaged will pass the top of the camera, and then pass the bottom of the camera. On the contrary, you need to set the Scan Direction parameter to **Backward** if the object being imaged will pass the bottom of the camera, and then pass the top of the camera. When you set the Scan Direction parameter to **Line 1**, you can also select the scan direction by injecting an externally generated electrical signal (Low = Forward, High = Reverse) into the pin 2 of the Control I/O receptacle on the camera.

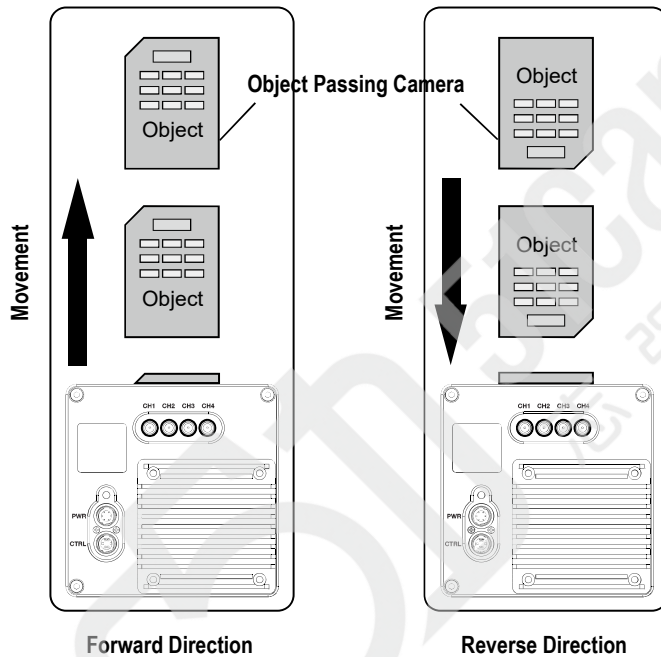

Figure 9-1 Scan Direction

XML Parameters		Value	Description
ImageFormatControl	Scan Direction	Forward	Scans images in the forward direction.
		Backward	Scans images in the backward direction.
		Line 1	Controls the direction depending on external signals

Table 9-5 XML Parameters related to Scan Direction

When you set the Scan Direction parameter to **Backward** in the Area mode, you can acquire vertically flipped images.

9.4 Region of Interest

The Region of Interest (ROI) feature allows you to specify a portion of the sensor lines. During operation, only the pixel information from the specified portion of the lines are read out of the sensor and transmitted from the camera to the frame grabber.

The ROI is referenced to the left end of the sensor array. The location and size of the ROI is defined by declaring the **Offset X** and **Width** settings. For example, suppose that you set the Offset X parameter to 24 and the Width parameter to 160 as shown in the figure below. With these settings, the camera will read out and transmit pixel values for pixels 24 through 184.

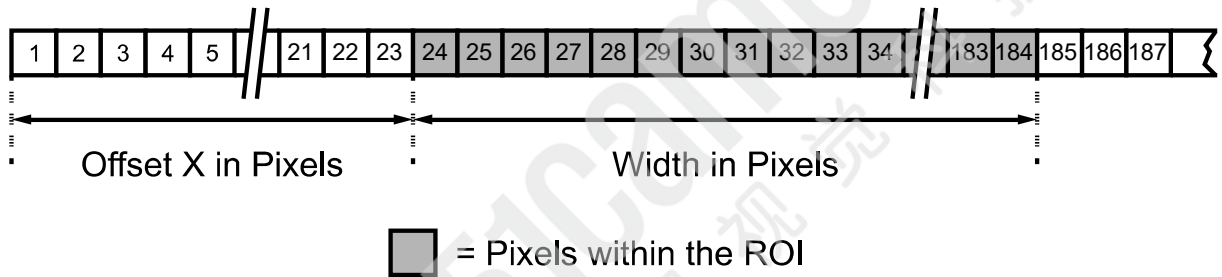

Figure 9-2 Region of Interest

The XML parameters related to ROI on the Linescan mode are as follows.

XML Parameters	Value †	Description
ImageFormat	Width 64-16384	Sets the Width of the Image ROI.
Control	OffsetX -	Sets the horizontal offset from the origin to the Image ROI.
	OffsetY 0	Sets the vertical offset from the origin to the Image ROI.

†: The unit for all parameters in this table is pixel.

Table 9-6 XML Parameters related to ROI

You can change the size of ROI by setting the **Width** parameters in the **Image Format Control** category. You can also change the position of the ROI origin by setting the **Offset X** parameter. Make sure that the **Width + Offset X** value is less than the **Width Max** value. You must set the size of the ROI first, and then set the Offset values since the **Width** parameter is set to its maximum value by default.

- The Width parameter must be set to a multiple of 32.
- The minimum allowed setting values for the ROI Width is 32.

**Caution!**

When you change the Image ROI settings after executing the Acquisition Start command, the camera may acquire abnormal images. Change the Image ROI settings after executing the Acquisition Stop command.

9.5 Binning

The Binning has the effects of increasing the level value and decreasing resolution by summing the values of the adjacent pixels and sending them as one pixel. The XML parameters related to Binning are as follows.

XML Parameters	Value	Description
ImageFormat Control	BinningSelector	Logic
	BinningHorizontal Mode	Sum, Average
	BinningHorizontal	×1, ×2
	BinningVertical	×1

Table 9-7 XML Parameters related to Binning

You can acquire images of approximately quadruple sensitivity with simultaneous use of Horizontal Binning and Vertical Binning in the case of setting the Sensor Binning mode.

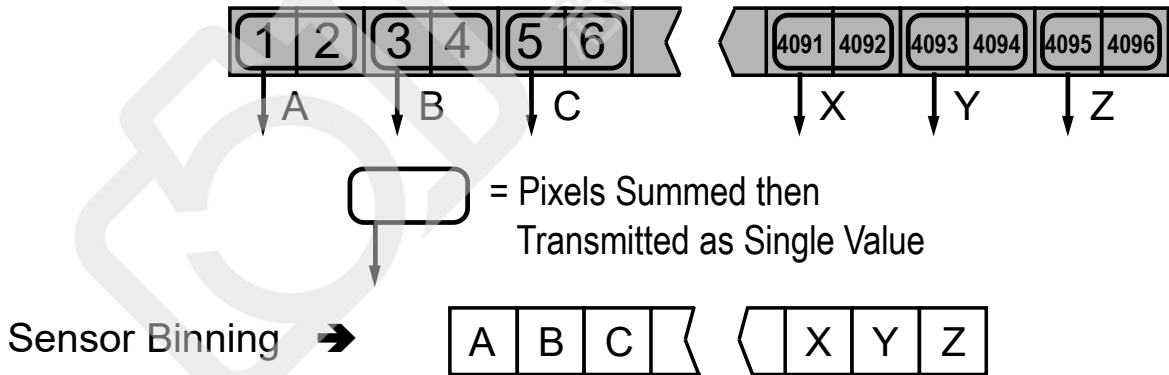

Figure 9-3 Sensor Binning

9.6 Pixel Format

You can determine the pixel format (8 bits, 10 bits or 12 bits) of image data transmitted from the camera by using the Pixel Format parameter.

The XML parameter related to Pixel Format is as follows.

XML Parameter	Description
ImageFormatControl PixelFormat	Sets the pixel format supported by the device.

Table 9-8 XML Parameter related to Pixel Format

The available pixel formats on the VT-9K5X2 cameras are as follows.

VT-9K5X2
Mono 8/10/12

Table 9-9 Pixel Format Values

9.7 Data ROI

The VT-9K5X2 camera provides the feature to correct Fixed Patter Noise in images by adjusting the parameters related to the Data ROI(Region of Interest). (Refer to 9.15 FPN Coefficients Control).

The XML parameters related to Data ROI are as follows.

XML Parameters	Value	Description
DataRoiControl	DataRoiSelector	FixedPatternNoise
	DataRoiOffsetX	-
	DataRoiOffsetY	-
	DataRoiWidth	-
	DataRoiHeight	-

Table 9-10 XML Parameters related to Data ROI

Only the pixel data from the area of overlap between the Data ROI by your settings and the Image ROI will be effective if you use the Image ROI and Data ROI at the same time. You can specify the numbers of lines to generate correction data by inputting the value in the Height parameter. A camera acquires images in the internal buffer as many as the specified number of lines and uses them for image correction.

The effective ROI is determined as shown in the figure below.

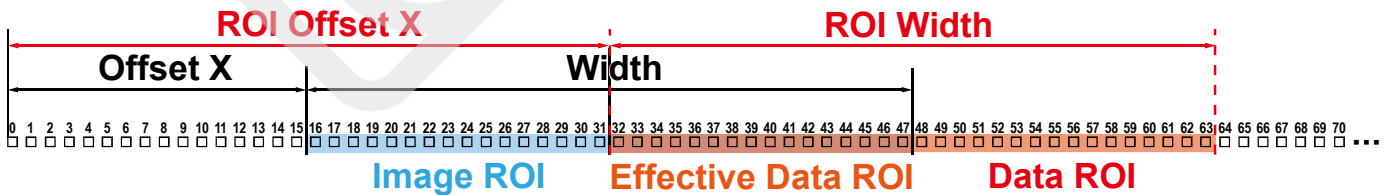

Figure 9-4 Effective Data ROI

9.8 Dual Band(HDR)

The operated sensor with divided into two of the bands is the biggest difference between the VT-9K5X2 product and the others.

Therefore, unlike the others, the central of the whole sensor is not positioned at the camera's center, and as the following figure, the central of Band1 that is the first band, is positioned at the camera's center, and there is an empty space between Band1 and Band2. It is recommended to work in consideration of the physical feature such as this when applying the number of Stage.

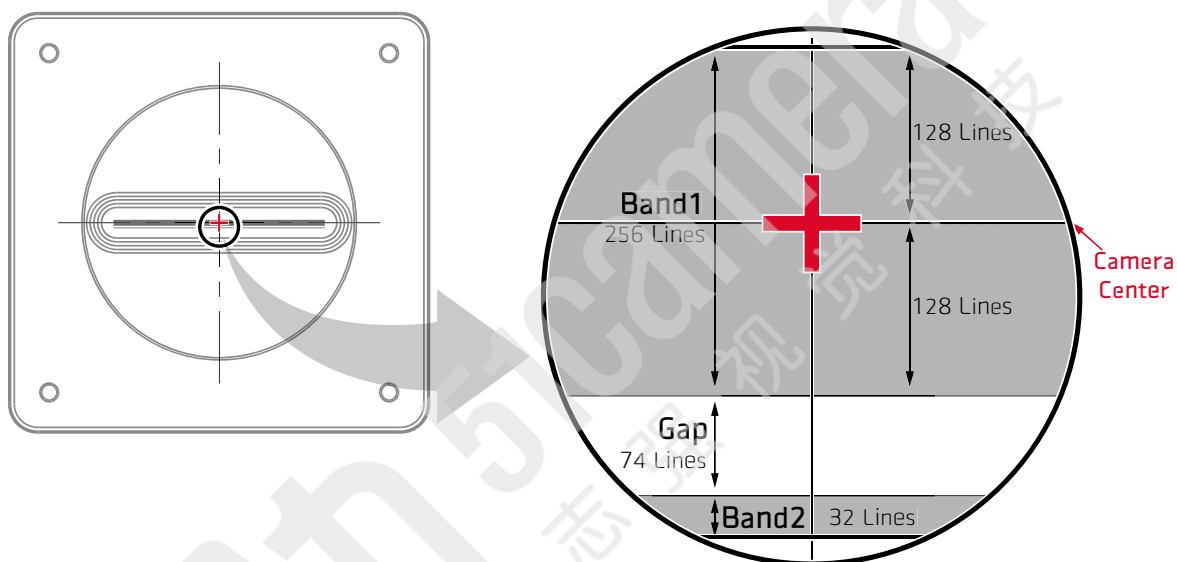

Figure 9-5 The Dual Band structure of the sensor

The VT-9K5X2 product supports to acquire very high sensitivity images by getting two of different sensitivity image each other via the Dual Band structure using spatial correction.

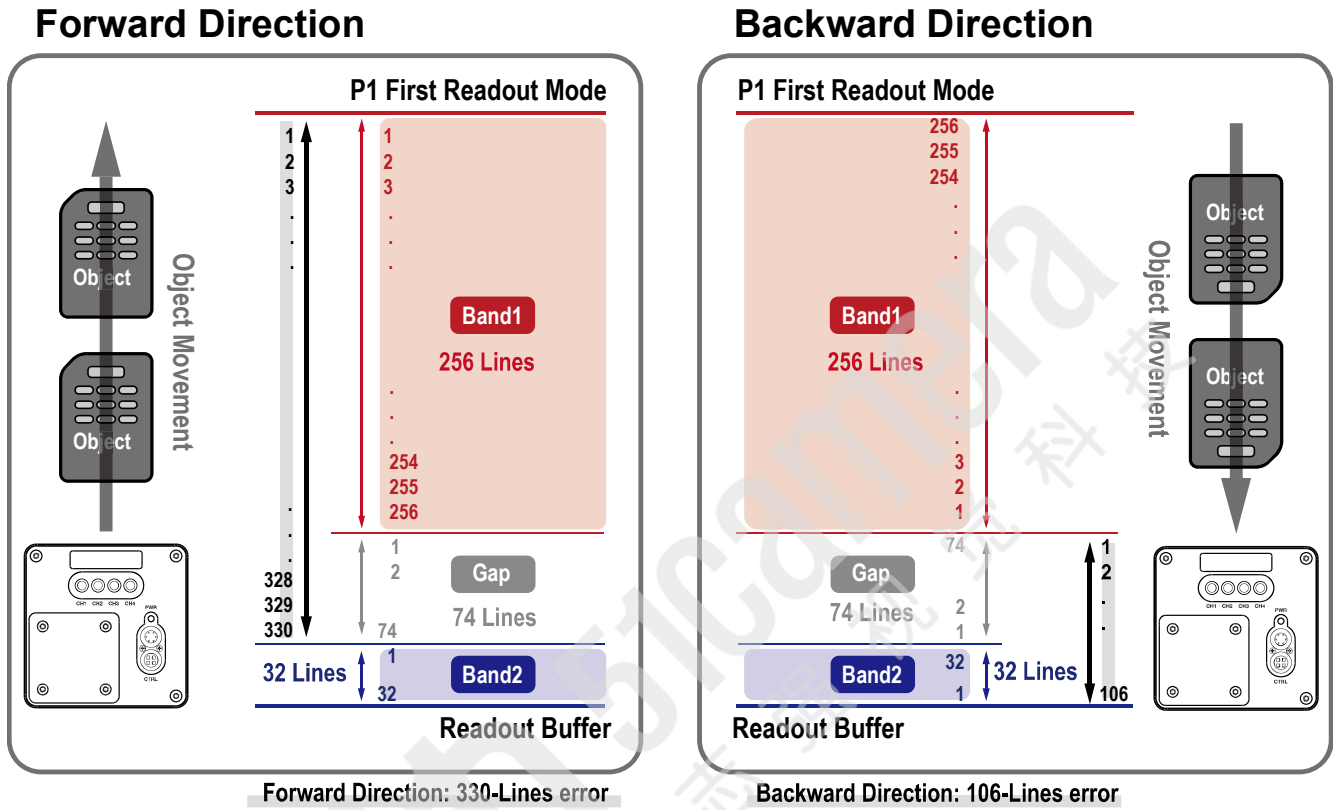

Figure 9-6 Errors depending on the directions of scan

As described above, the VT-9K5X2 sensor has a gap between Band1 and Band2 physically by 74 lines. Therefore, for the distance of the 74 lines, when readout is executed in the direction of forward or backward, the value of the line error is calculated as the following formula.

(Assuming Band1=256, Band2=32 as the figure above)

- Forward: $256 + 74 = 330$ lines
- Backward: $74 + 32 = 106$ lines

To compensate for the line error between the two bands, this product stores the image acquired by Band1 and then delays and outputs it by the value of the line error, and it is called the Spatial Correction function.

When executing readout in the direction of forward or backward, the Spatial Correction function corrects the distance difference between the two bands and it outputs the image from Band1 and Band2 alternately.

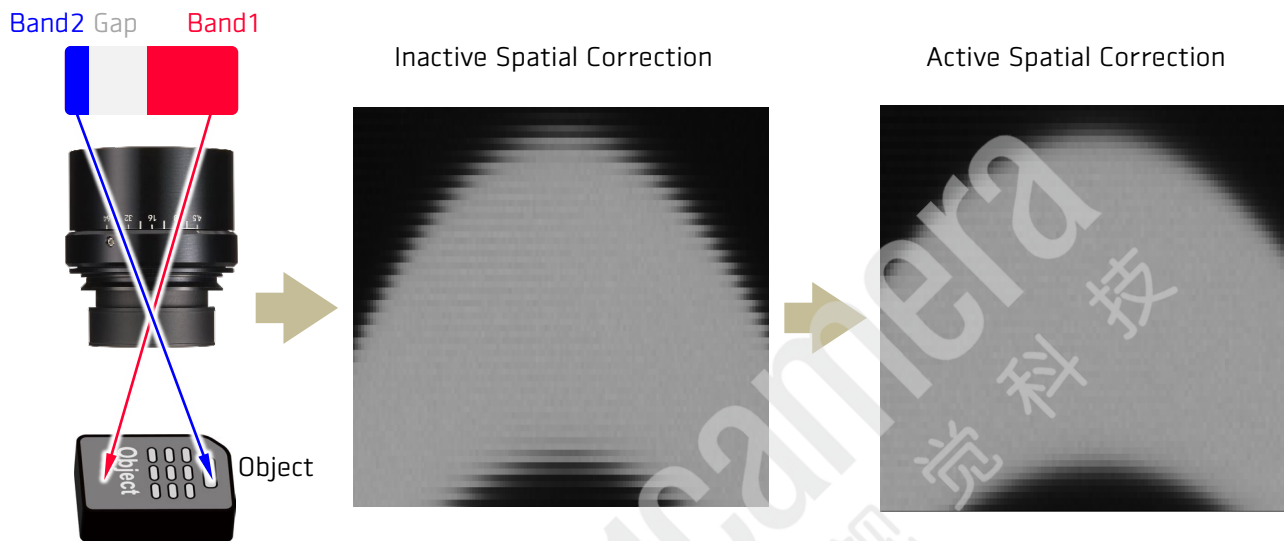
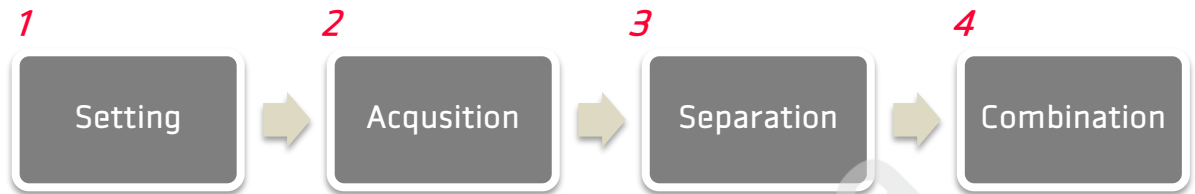
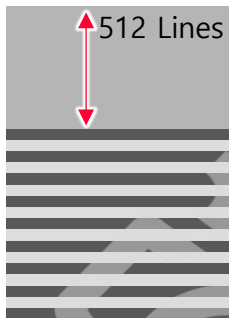

Figure 9-7 Spatial Correction

To obtain an HDR image through two of the images acquired by applying the Dual Band function, two images are combined in the following order:



1. Set pixel data, line rate, TDI Stages to use, and run the `AcquisitionStart` command on a frame grabber to input to a camera.
2. In the beginning of image acquisition, an incorrect image may be output due to electrons accumulated before the sensor operates. Therefore, in consideration of the spatial correction, it is recommended to use from the first line after 'the number of 512 lines', to inspect images.



3. After the image is acquired all, separate and gather even/odd lines to create 2 frames of the images as shown in the figure below.

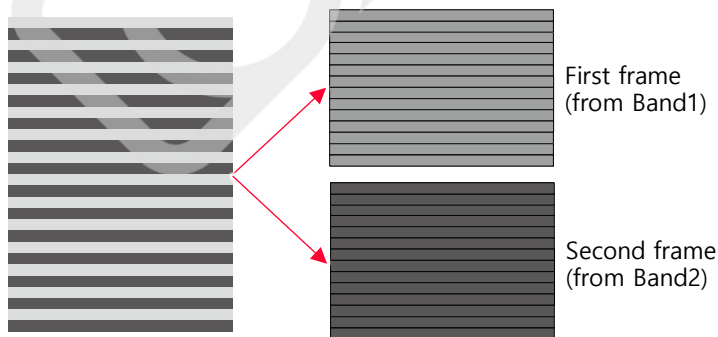

4. To obtain an HDR image, combine two frames by using the following formula:

First frame \times ratio A + Second frame \times ratio B

For example, ratio A is 0.5 and ratio B is 0.5, the two frames will affect on the combined image equally. And in case that ratio A is set to 0.8 and ratio B 0.2, the first frame affect more than those of the second on the combined image.

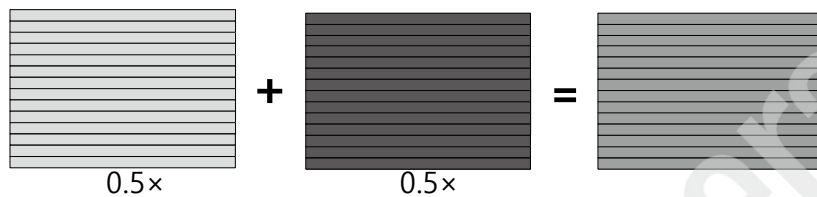

9.9 Gain and Black Level

Increasing the **Gain** parameter increases all pixel values of the image. This results in a higher grey value output from the camera for a given amount of output from the image sensor.

1. Selects the Gain Control (**Analog All** or **Digital All** are available) to be adjusted by using the **Gain Selector** parameter.
2. Sets the **Gain** parameter to the desired value.

Adjusting the **Black Level** parameter will result in an offset to the pixel values output from the camera.

1. Selects the Black Level Control (**Digital All** is only available) to be adjusted by using the **Black Level Selector** parameter.
2. Sets the **Black Level** parameter to the desired value. The available setting range varies depending on the **Pixel Format** settings.

The XML parameters related to Gain and Black Level are as follows.

XML Parameters	Value	Description	
Analog Control	GainSelector	AnalogBand1	Applies the Gain value to the analog channel of Band1.
		AnalogBand2	Applies the Gain value to the analog channel of Band2.
		Digital All	Applies the Gain value to all digital channels.
Gain	2.0x, 2.5x, 3x, 3.5x, 4x, 4.5x, 5x, 5.5x, 6x, 6.5x, 7x, 7.5x, 8x	Sets an analog gain value for Band1 or Band2.	
	1.0x ~ 32.0x	Sets a digital gain value.	
BlackLevel Selector	BlackLevelSelector	AnalogBand1	Applies the Black Level value to the analog channel of Band1.
		AnalogBand2	Applies the Black Level value to the analog channel of Band2.
		Digital All	Applies the Black Level value to all digital channels.
BlackLevel	from -256 to 255	Sets a black level value (The setting range is based on the 8-bit pixel format.).	
BlackLevel CalibrationAuto	-	8 bit: Adjusts automatically to the black level of about 20 10 bit: Adjusts automatically to the black level of about 60 12 bit: Adjusts automatically to the black level of about 180	

Table 9-11 XML Parameters related to Gain and Black Level

Automatic Adjusted Values via BlackLevelCalibrationAuto:



The black level values shown in the table above are the values that appear only when the Optical Black Clamp is deactivated (Off) and both DSNU and PRNU corrections are turned off. If these features are turned on, they will be adjusted to different values from those shown above.

9.10 Optical Black Clamp

The Optical Black Clamp function allows to correct changes of pixel values due to changes of sensor temperature. With this function, the VT-9K5X2 camera minimizes changes of pixel's level by temperature through removing offsets from temperature differences in real time.

The XML parameters related to Optical Black Clamp are as follows.

XML Parameters		Value	Description
Analog Control	OpticalBlack Clamp	Off	Deactivates the Optical Black Clamp function.
		On	Activates the Optical Black Clamp function.

Table 9-12 XML Parameters related to Optical Black Clamp

9.11 Optical Black Clamp Weight

When using the VT-9K5X2 camera on higher line rates than 470 kHz at 8 bit or 240 kHz at 10 bit, horizontal-noise patterns may occur due to the sensor's characteristics. In this case, the Optical Black Clamp Weight function is recommended to correct these noise patterns. To minimize these noise patterns, proceed the steps of the camera correction described in **Error! Reference source not found.** of this manual, and after that, adjust the `OpticalBlackClampWeight` value.

The XML parameters related to Optical Black Clamp Weight are as follows.

XML Parameters		Value	Description
AnalogControl	OpticalBlackClamp Weight	0 ~ 1	Adjusts the OpticalBlackClampWeight value (Default value: 1)

Table 9-13 XML Parameters related to Optical Black Clamp Weight

9.12 LUT

The Lookup Table (LUT) feature allows you to convert original image values to certain level values.

Luminance

Since it is mapped one to one for each level value, 12 bit output can be connected to 12 bit input. The LUT is in the form of table that has 4096 entries between 0 ~ 4095 and the VT-9K5X2 cameras provide a non-volatile space for LUT data storage.

You can determine whether to apply LUT. For more information about how to download LUT to the camera, refer to Appendix B.

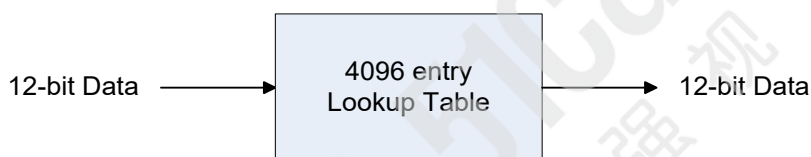

Figure 9-8 LUT Block

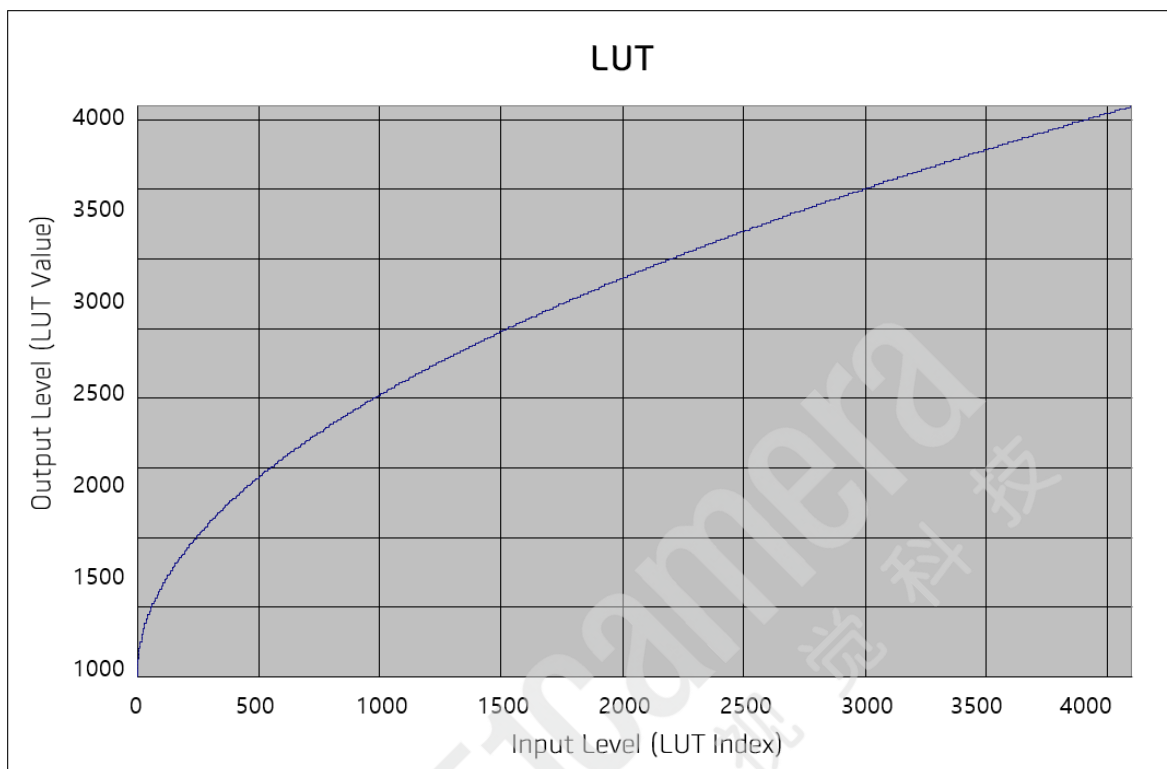

Figure 9-9 LUT at Gamma 0.5

The XML parameters related to LUT are as follows.

XML Parameters	Value	Description	
LUTControl	LUTSelector	Luminance	Luminance LUT
	LUTEnable	True	Activates the selected LUT.
		False	Deactivates the selected LUT.
	LUTIndex	0 ~ 4095	Selects the index(Input Level) to apply the LUTValue to.
	LUTValue	0 ~ 4095	Output value of the current LUT corresponding to the input value of LUT Index
	LUTSave	-	Saves the current LUT data to the non-volatile memory.
	LUTLoad	-	Loads the LUT data from the non-volatile memory.

Table 9-14 XML Parameters related to LUT

9.13 Dark Signal Non-uniformity Correction

In theory, when a digital camera acquires images in complete darkness, all of the pixel values in the image should be near zero and they should be equal. In practice, however, slight variations in the performance of the pixels in the sensor will cause some variations in the pixel values output from the camera when the camera is acquiring in darkness. This variation is known as Dark Signal Non-uniformity (DSNU). The VT-9K5X2 cameras provide the DSNU Correction feature.

The XML parameters related to DSNU are as follows.

XML Parameters	Value	Description
DSNU DSNUDataSelector	-	Chooses the DSNU data.
DSNU DSNUDataGenerate	-	Generates the DSNU data.
DSNU DSNUDataGenerateAll	-	Generates and saves the DSNU data for each Analog Gain setting value (1×, 2×, 3×, 4×).
DSNU DSNUDataSave	-	Saves the generated DSNU data in the non-volatile memory. The generated data by executing the DSNUDataGenerate parameter are saved in the volatile memory so that the data are lost if the camera is reset or if power is turned off. To use the data after the camera is powered on or reset, save them in the non-volatile memory.
DSNU DSNUDataLoad	-	Loads the DSNU data from the non-volatile memory into the volatile memory.

Table 9-15 XML Parameters related to DSNU



Note:

The VT-9K5X2 camera automatically calculates and applies different DSNU correction values to Band1 and Band2 respectively.

9.13.1 Generating and Saving User DSNU Correction Values

To generate and save user DSNU correction values, use the following procedure.



Note:

For optimum DSNU correction results, we recommend that you generate DSNU data after the temperature of the camera housing has been stabilized.

1. The camera will use the entire sensor when generating DSNU correction values. The DSNU correction value refers to the current setting values of the **OffsetX** and the **Width** range, therefore, we recommend to check setting of these values in advance.
2. Ensure that the camera will be acquiring line images in complete darkness by covering the camera lens, closing the iris in the lens, or darkening the room.
3. Begin acquiring line images either by setting the camera for the Free-Run mode or by supplying external trigger signals to trigger line acquisitions.
4. Generate DSNU correction values.
5. If you execute the **DSNU Data Generate** command,
 - a. The camera generates DSNU data according to the current **Analog Gain** setting value. The camera must acquire at least 1024 line images to create a set of DSNU correction values.
 - b. After completing 1024 line acquisitions, the generated DSNU correction values will be activated and saved in the camera's volatile memory.
 - c. To save the generated DSNU correction values in the camera's flash(non-volatile) memory, execute the **DSNU Data Save** command. The previous DSNU values for the current **Analog Gain** setting value saved in the memory will be overwritten.
6. If you change the **Analog Gain** setting value or want to load the existing values in the flash memory, execute the **DSNU Data Load** command.

9.14 Photo Response Non-uniformity Correction

In theory, when a line scan camera acquires images with the camera viewing a uniform light-colored target in bright light, all of the pixel values in the image should be near the maximum grey value and they should be equal. In practice, however, slight variations in the performance of the pixels in the sensor, variations in the optics, and variations in the lighting will cause some variations in the pixel values output from the camera. This variation is known as Photo Response Non-uniformity (PRNU). The VT-9K5X2 cameras provide the PRNU Correction feature and sixteen storage locations for PRNU correction values.

The XML parameters related to PRNU are as follows.

XML Parameters	Value	Description
PRNU PRNUCorrection	False	Disables the PRNU Correction feature.
	True	Enables the PRNU Correction feature.
PRNUSelector	Default, Space1-Space15	Selects a location to save PRNU data to or load PRNU data from.
PRNUTargetLevelAUTO	False	Select to set the PRNU Target Level manually.
	True	Select to set the PRNU Target Level automatically.
PRNUTargetLevel	0 - 255	Sets the PRNU Target Level (@ 8 bit pixel format).
PRNUDataGenerate	-	Generates the PRNU data.
PRNUDataSave	-	Saves the generated PRNU data in the non-volatile memory. The generated data by executing the PRNUDataGenerate parameter are saved in the volatile memory so that the data are lost if the camera is reset or if power is turned off. To use the data after the camera is powered on or reset, save them in the non-volatile memory.
PRNUDataLoad	-	Loads the PRNU data from the non-volatile memory into the volatile memory.

Table 9-16 XML Parameters related to PRNU



Note:

The VT-9K5X2 camera automatically calculates and applies different PRNU correction values to Band1 and Band2 respectively.

9.14.1 Generating and Saving User PRNU Correction Values

To generate and save user PRNU correction values, use the following procedure.



Note:

- We strongly recommend that you generate new PRNU correction values whenever you make a change to the optics or lighting or if you change the camera's line rate.
- For optimum PRNU correction results, we recommend that you generate DSNU correction values first before generating PRNU correction values.
- If PRNU Target Level is set to Auto (PRNU Target Level Auto: True), Band1 and Band2 are automatically adjusted to the highest level respectively.
- If PRNU Target Level is set to Manual (PRNU Target Level Auto: False), Band1 and Band2 are adjusted to the set level.

1. The camera will use the entire sensor when generating PRNU correction values. The PRNU correction value refers to the current setting values of the OffsetX and the Width range, therefore, we recommend to check setting of these values in advance.
2. Place a uniform white target in the field of view of the camera. Adjust the optics, lighting and line rate as you would for normal operation. We recommend that you make adjustments to achieve the digital output level in a range from 100 to 200 (Gain: 1.00 at 8 bit).
3. Begin acquiring line images either by setting the camera for the Free-Run mode or by supplying external trigger signals to trigger line acquisition.
4. Set the Target Level.
To set the Target Level automatically, select the Target Level AUTO check box.
To set the Target Level manually, deselect the Target Level AUTO check box and input the target level in a range from 0 to 255.
5. Execute the PRNU Generate command to generate PRNU correction values.
6. The camera must acquire at least 1024 line images to create a set of PRNU correction values.
7. After completing 1024 line acquisitions, the generated PRNU correction values will be activated and saved in the camera's volatile memory.
8. To save the generated PRNU correction values in the camera's Flash (non-volatile) memory, specify a location to save by using the PRNU Selector parameter and execute the PRNU Save command. The existing values in the memory will be overwritten.

To ignore the generated PRNU correction values and load the existing values in the Flash memory, specify a location to load from by using the PRNU Selector parameter and execute the PRNU Load command.

9.15 FPN Coefficients Control

The FPN Coefficients Control feature provides function to correct Fixed Pattern Noise for acquired images. The VT-9K5X2 camera provides the feature to correct images after acquiring those, by adding Black Level to the value of the DSNU correction, or by multiplying Gain by the value of the PRNU correction.

The XML parameters related to FPN Coefficients Control are as follows.

XML Parameters		Value	Description
FPN Coefficients Control	DSNUCoefficient	-	Sets a value of Black Level to add to current value of the DSNU correction.
	DSNUCoefficientApply		Sets a value of Black Level to add to current value of the DSNU correction.
	PRNUCoefficient	-	Sets a Gain value to multiply by current value of the PRNU correction.
	PRNUCoefficientApply	-	Applies the value above to the value of the PRNU correction.

Table 9-17 XML Parameters related to FPN Coefficients Control

9.16 CXP Link Configuration

The VT-9K5X2 cameras must be connected to a CXP Frame Grabber installed in your computer via CoaXPress interface. CoaXPress interface allows you to connect a camera to a CXP Frame Grabber by using simple coax cabling and allows up to 12.5 Gbps data rate per cable. Four-channel VT-9K5X2 cameras support one master connection and three extension connections to configure a link. In compliance with the CoaXPress standard, the VT-9K5X2 cameras include an automatic link detection (Plug and Play) mechanism to correctly detect the camera to CXP Frame Grabber connections.

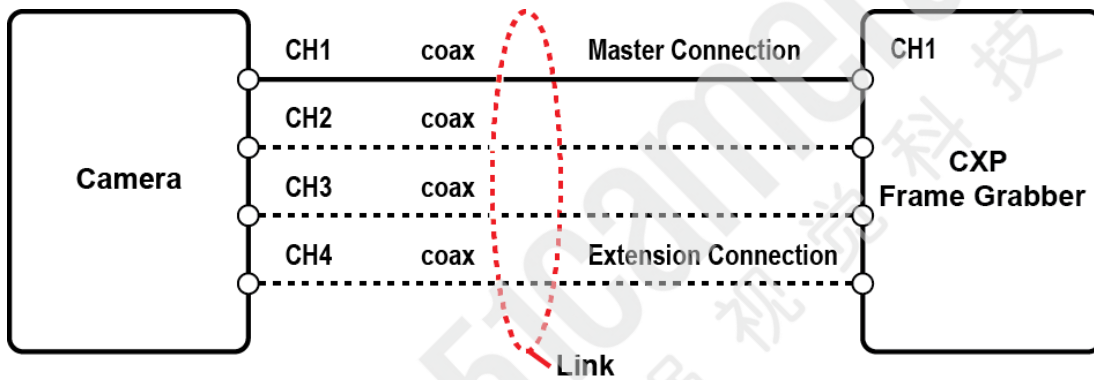

Figure 9-10 CXP Link Configuration

The XML parameters related to the link configuration between the camera and CXP Frame Grabber are located in the CoaXPress category under the Transport Layer Control as shown below.

XML Parameters	Value	Description
CoaXPress CxpLinkConfiguration Preferred	Read Only	Displays bit rate and the number of connections to be set for the link configuration between the camera and Host (Frame Grabber) while discovering devices.
CXPLinkConfiguration	CXP1_X1, X2, X4 CXP3_X1, X2, X4 CXP5_X1, X2, X4 CXP6_X1, X2, X4 CXP10_X1, X2, X4 CXP12_X1, X2, X4	Forcefully sets bit rate and the number of connections for the link configuration. e.g.) CXP12_X4: Four connections running at the maximum of CXP12 speed (12.5 Gbps)

Table 9-18 XML Parameters related to CXP Link Configuration

9.17 Digital I/O Control

The Control I/O receptacle of the camera can be operated in various modes.

The XML parameters related to Digital I/O Control are as follows.

XML Parameters	Value	Description	
DigitalIOControl	LineSelector	Line0	Sets the pin of No.1 among 4 pins of the Control I/O receptacle to configure input signals for features related to counters, timers, or the others.
		Line1	Sets the pin of No.3 among 4 pins of the Control I/O receptacle to configure about output signals.
	LineMode	Input	Appears under Line0 is chosen.
		Output	Appears under Line1 is chosen.
	LineInverter	FALSE	Disables inversion on the output signal of the line.
		TRUE	Enables inversion on the output signal of the line.
	LineSource	Off	Disables the line output.
		High	High output.
		LinkTrigger	Outputs pulse signals set by LinkTrigger.
		UserOutput0	Outputs pulse signals set by User Output Value.
		Timer0Active	Outputs user-defined Timer signals as pulse signals.
		Strobe 0	Outputs pulse signals set by Strobe0
		UserOutput Selector	User Output 0
	UserOutput Value	FALSE	Sets the bit state of the line to Low.
		TRUE	Sets the bit state of the line to High.
	StrobeSelector	Strobe0	Sets Strobe Selector
	StrobeMode	Timed	Outputs pulse signals according to the Strobe Duration setting value.
		TriggerWidth	Outputs pulse signals of which the pulse width is equal to the trigger signals applied to the camera.
	StrobeDelay	0~1000 μ s	Sets a delay to the current output signal in microseconds.
	StrobeDuration	1~1000 μ s	Sets a duration of pulse signal in microseconds when the Strobe Mode is set to Timed.

Table 9-19 XML Parameters related to Digital I/O Control

Outputs pulse signals indicating the current exposure time.

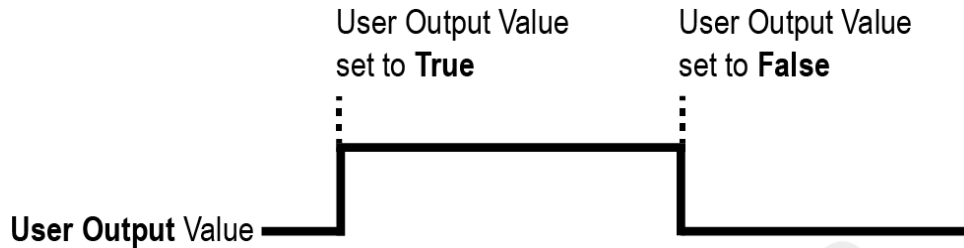

Figure 9-11 User Output

The camera can provide an Exposure Active output signal. The signal goes high when the exposure time for each frame acquisition begins and goes low when the exposure time ends as shown in the figure below. This signal can be used as a flash trigger and is also useful when you are operating a system where either the camera or the object being imaged is movable. Typically, you do not want the camera to move during exposure. You can monitor the Exposure Active signal to know when exposure is taking place and thus know when to avoid moving the camera.

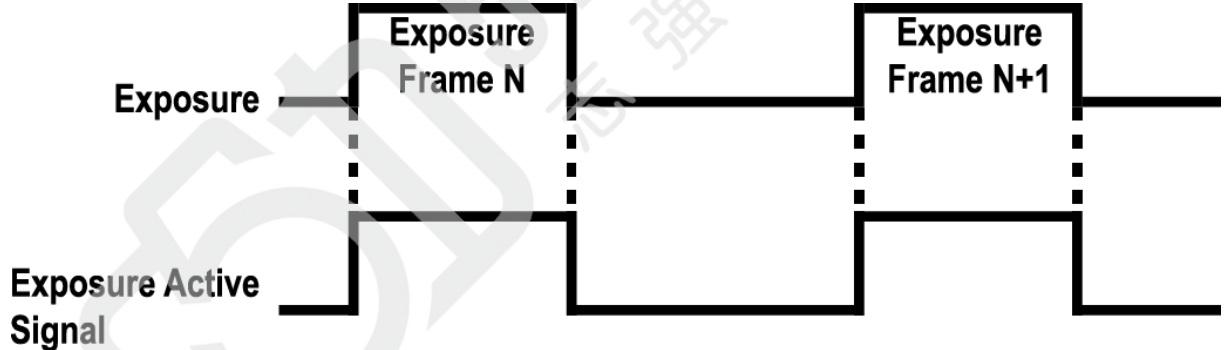

Figure 9-12 Exposure Active Signal

9.18 Debounce

The Debounce feature of the VT-9K5X2 cameras allows to supply only valid signals to the camera by discriminating between valid and invalid input signals. The Debounce Time parameter specifies the minimum time that an input signal must remain High or Low in order to be considered as a valid input signal. When you use the Debounce feature, be aware that there is a delay between the point where the valid input signal arrives and the point where the signal becomes effective. The duration of the delay is determined by the Debounce Time parameter setting value.

When you set the Debounce Time parameter, High and Low signals shorter than the setting value are considered invalid and ignored as shown in the figure below.

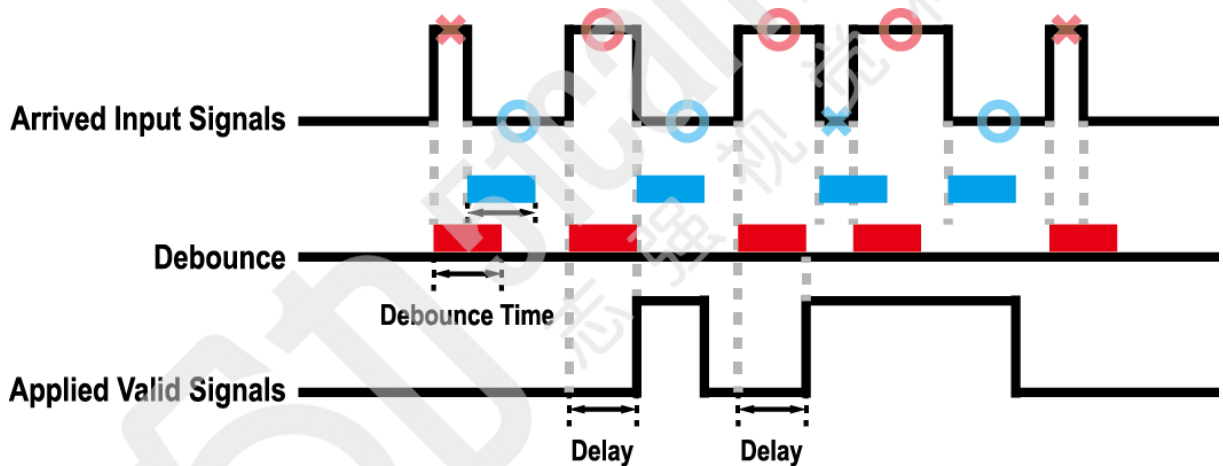

Figure 9-13 Debounce

9.19 Temperature Monitor

The camera has an embedded sensor chip to monitor the internal temperature.

The XML parameters related to Device Temperature are as follows.

XML Parameters		Value	Description
DeviceControl	DeviceTemperature Selector	Mainboard	Sets a temperature measuring spot to the mainboard.
	DeviceTemperature	-	Displays device temperature in Celsius.

Table 9-20 XML Parameters related to Device Temperature



Partial Shutdown

It is recommended to keep the temperature of the camera's face plate below +55°C, and to keep the internal temperature below 65°C, for stable operation. On some environment unable to use cooling devices such as fans, the camera's temperature will get hotter at the same time if the temperature of convection becomes hot. When the temperature inside the camera exceeds +75°C±2, the camera activates a Partial Shutdown mode to protect the product. In this case, it is available to send commands to the camera, however, images will not be acquired, and the camera's power will be reduced to about 70% of the normal operating standard.

To recover from partial shutdown mode, turn off the camera and allow the camera to cool sufficiently before operating again.

9.20 Status LED

A LED is installed on the rear panel of the camera to inform the operation status of the camera.

LED status and corresponding camera status are as follows:

Status LED	Descriptions
Steady Red	Camera is not initialized.
Slow Flashing Red	A CXP link is not configured.
Fast Flashing Red	Camera is on the partial shutdown mode due to its temperature exceeding the recommendation.
Fast Flashing Orange	Camera is checking a CXP link configuration.
Steady Green	A CXP link is configured.
Fast Flashing Green	Camera is acquiring images.

Table 9-21 Status LED

9.21 Test Pattern

To check whether the camera operates normally or not, it can be set to output test patterns generated in the camera, instead of image data from the image sensor. Four types of test patterns are available; images with different values in horizontal direction (Grey Horizontal Ramp), images with different values in diagonal direction (Grey Diagonal Ramp), moving images with different values in diagonal direction (Grey Diagonal Ramp Moving) and images with different values in horizontal direction output from the image sensor (Sensor Specific).

The XML parameter related to Test Pattern is as follows.

XML Parameter	Value	Description	
ImageFormatControl	TestPattern	Off	Disables the Test Pattern feature.
	GreyHorizontalRamp		Sets to Grey Horizontal Ramp.
	GreyDiagonalRamp		Sets to Grey Diagonal Ramp.
	GreyDiagonalRampMoving		Sets to Grey Diagonal Ramp Moving.
	SensorSpecific		Sets to the Test Pattern generated by the image sensor.

Table 9-22 XML Parameter related to Test Pattern



Figure 9-14 Grey Horizontal Ramp



Figure 9-15 Grey Diagonal Ramp



Figure 9-16 Grey Diagonal Ramp Moving

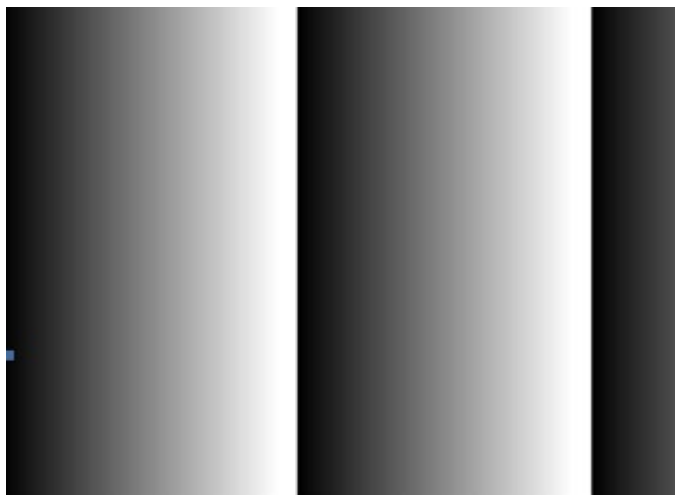

Figure 9-17 Sensor Specific

51camera
志强视觉科技

9.22 Reverse X

The Reverse X feature lets you flip images horizontally. This feature is available in almost all of operation modes of the camera, except for the Test Image mode.

XML Parameter	Value	Description
ImageFormatControl ReverseX	FALSE	Disables the Reverse X feature.
	TRUE	Flips images horizontally.

Table 9-23 XML Parameter related to Reverse X



Figure 9-18 Original Image



Figure 9-19 Reverse X Image

9.23 Counter Control

The VT-9K5X2 camera provides the Counter feature to count certain camera events. For example, you can verify the number of external trigger signals applied to the camera.

The XML parameters related to Counter Control are as follows.

XML Parameters		Value	Description
CounterAnd TimerControl	CounterSelector	Counter0	Selects a Counter to configure.
	CounterEvent Activation	RisingEdge	Counts on the rising edge of the selected Event Source signal.
FallingEdge		Counts on the falling edge of the selected Event Source signal.	
CounterEvent Source	CounterEvent Source	Off	Stops the Counter.
		FrameActive	Counts the number of FrameActive signals.
		ExposureActive	Counts the number of ExposureActive signals.
		LineActive	Counts the number of Line Active signals.
		LinkTrigger0	Counts the number of LinkTrigger0 signals.
		Line0	Counter the number of external trigger signals.
CounterReset Source	CounterReset Source	Off	Disables the Counter Reset trigger.
		FrameActive	Uses the FrameActive signal as Reset Source.
		ExposureActive	Uses the ExposureActive signal as Reset Source.
		AcquisitionActive	Uses the AcquisitionActive signal as Reset Source.
CounterReset Activation	CounterReset Activation	Line0	Uses the Line0 signal as Reset Source.
		RisingEdge	Resets Counter on the rising edge of the selected Reset Source signal.
		FallingEdge	Resets Counter on the falling edge of the selected Reset Source signal.
		AnyEdge	Resets Counter on the rising/falling edge of the selected Reset Source signal.
		LevelHigh	Resets the Counter if the level of the selected Reset Source signal is High.
		LevelLow	Resets the Counter if the level of the selected Reset Source signal is Low.
CounterReset	-	Resets the selected Counter and restarts.	
CounterValue	-	Displays the current value of the selected Counter.	
CounterValue AtReset	-	Displays the value of the Counter when it was reset by the Counter Reset command.	

Table 9-24 XML Parameters related to Counter Control (1)

XML Parameters	Value	Description	
CounterAnd TimerControl	CounterDuration	1 – 4294967295	Sets the duration or number of events to count before the Counter ends.
	CounterStatus	-	Displays the current status of the Counter.
	CounterTrigger Source	Off	Disables the Counter Trigger Source function.
		FrameActive	Uses the FrameActive signal as Trigger Source of Counter.
		ExposureActive	Uses the ExposureActive signal as Trigger Source of Counter.
		AcquisitionActive	Uses the AcquisitionActive signal as Trigger Source of Counter.
		Line0	Uses the Line0 signal as Trigger Source of Counter.
	CounterTrigger Activation	RisingEdge	Starts Counter on the rising edge of the selected Counter Trigger Source signal.
		FallingEdge	Starts Counter on the falling edge of the selected Counter Trigger Source signal.
		AnyEdge	Starts Counter on the rising/falling edge of the selected Counter Trigger Source signal.
LevelHigh		Resets the Counter if the level of the selected Counter Trigger Source signal is High.	
LevelLow		Resets the Counter if the level of the selected Counter Trigger Source signal is Counter.	

Table 9-25 XML Parameters related to Counter Control (2)

9.24 Timer Control

When the Sector parameter is set to Line1 and the Line Source parameter to Timer(Timer0Active), the camera can provide output signals by using the Timer. On the VT-9K5X2 camera, the Exposure Active, Frame Active, or external trigger signal is available as Timer source signal.

The XML parameters related to Timer Control are as follows.

XML Parameters	Value	Description
CounterAnd TimerControl	TimerSelector Timer0	Selects a Timer to configure.
	TimerDuration 1 - 60,000,000 μ s	Sets the duration of the Timer output signal to be used when Timer Trigger Activation is set to Rising / Falling Edge.
	TimerDelay 0 - 60,000,000 μ s	Sets the delay time to be applied before starting the Timer.
	TimerReset -	Resets the Timer and starts it again.
	TimerTrigger Source	Off ExposureActive FrameActive Line0
	TimerTrigger Activation	RisingEdge FallingEdge LevelHigh LevelLow
		Disables the Timer trigger. Sets the ExposureActive signal as the source signal. Sets the Timer to use a frame readout time as the source signal. Sets the Timer to use the external trigger signal as the source signal. Specifies that a rising edge of the selected trigger signal will act as the Timer trigger. Specifies that a falling edge of the selected trigger signal will act as the Timer trigger. Specifies that the Timer output signal will be valid as long as the selected trigger signal is High. Specifies that the Timer output signal will be valid as long as the selected trigger signal is Low.

Table 9-26 XML Parameters related to Timer Control

For example, when the Timer Trigger Source is set to Exposure Active and the Timer Trigger Activation is set to Level High, the Timer will act as follows.

1. When the source signals set by the Timer Trigger Source parameter are applied, the Timer will start operations.
2. The delay set by the Timer Delay parameter begins to expire.
3. When the delay expires, the Timer signal goes high as long as the source signal is high.

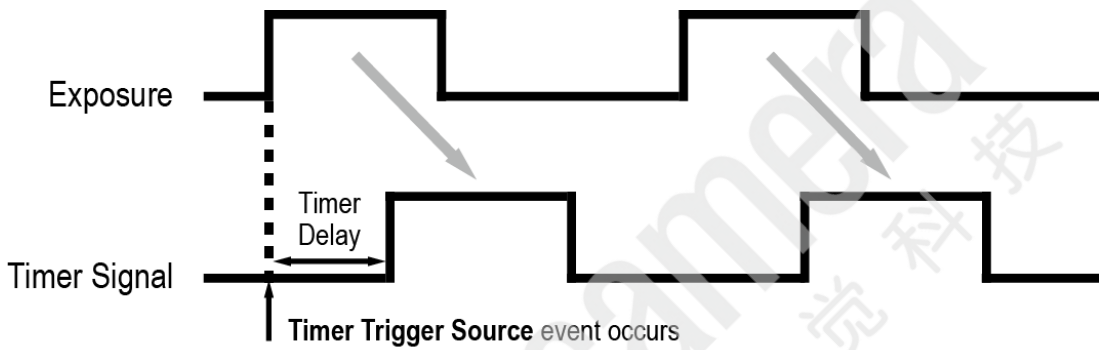

* Timer Trigger Activation is set to Level High.

Figure 9-20 Timer Signal

9.25 Device User ID

You can input user-defined information up to 32 bytes.

The XML parameter related to Device User ID is as follows.

XML Parameter	Description
DeviceControl DeviceUserID	Input user-defined information (32 bytes).

Table 9-27 XML Parameter related to Device User ID

9.26 Device Reset

Resets the camera physically to power off and on.

The XML parameter related to Device Reset is as follows.

XML Parameter	Description
DeviceControl Device Reset	Resets the camera physically.

Table 9-28 XML Parameter related to Device Reset

9.27 Field Upgrade

The camera provides a feature to upgrade the Firmware and FPGA logic through the Camera Link interface without disassembling the camera in the field. Refer to **Appendix A** for more details about how to upgrade.

9.28 User Set Control

You can save the current camera settings to the camera's internal Flash memory. You can also load the camera settings from the camera's internal Flash memory. The camera provides two setups to save and three setups to load settings.

The XML parameters related to User Set Control are as follows.

XML Parameters	Value	Description	
UserSetControl	UserSetSelector	Default	Selects the Factory Default settings.
		UserSet1	Selects the User Set1 settings.
		UserSet2	Selects the User Set2 settings.
UserSetLoad	-	Loads the User Set specified by User Set Selector to the camera.	
UserSetSave	-	Saves the current settings to the User Set specified by User Set Selector. The Default is a Factory Default settings and allowed to load only.	
UserSetDefault	Default	Applies the Factory Default settings when reset.	
	User Set1	Applies the User Set1 settings when reset.	
	User Set2	Applies the User Set2 settings when reset.	

Table 9-29 XML Parameters related to User Set Control

The camera settings stored in the Default can be loaded into the camera's workspace but cannot be changed. The settings set in the workspace will be lost if the camera is reset or powered off. To use the current setting values in the workspace after a reset, you must save the settings to one of the user spaces.

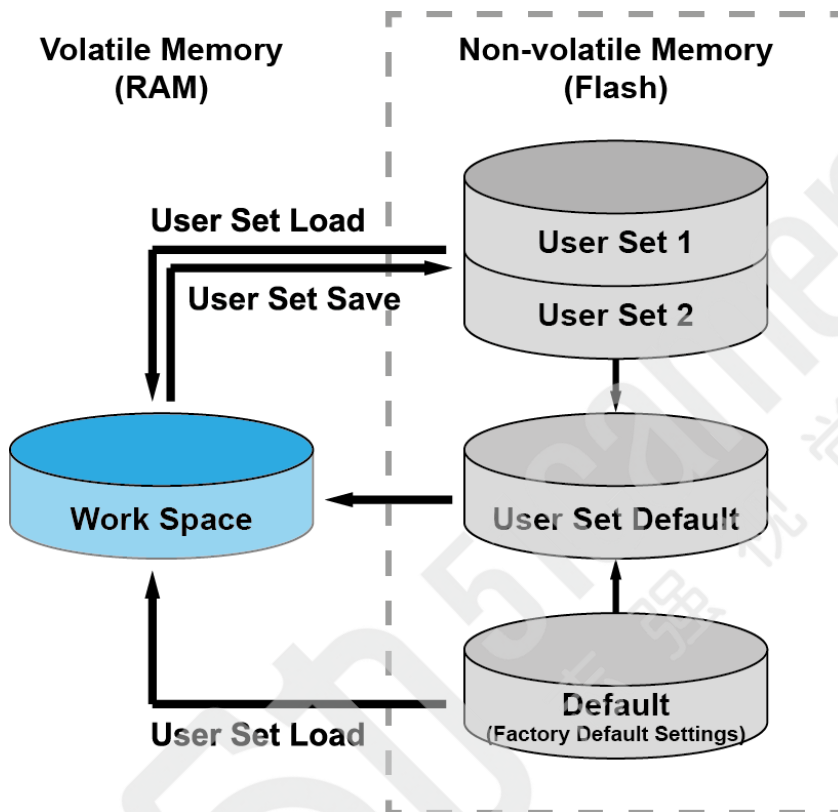

Figure 9-21 User Set Control

Chapter 10. Troubleshooting

When you have a problem with a Vieworks camera, please check the followings:

- If no image is displayed on your computer,
 - Ensure that all cable connections are secure.
 - Ensure that the power supply is properly connected.
 - Ensure that trigger signals are applied correctly when you operate the camera with trigger signals.
- If images are not clear,
 - Ensure the camera lens or glass is clean.
 - Check the lens aperture is adjusted properly.
- If images are dark,
 - Ensure the camera lens is not blocked.
 - Check the exposure time is set properly.
- If you identify abnormal operation or overheating sign,
 - Ensure the power supply is properly connected.
 - Stop using the camera when you notice smoke or abnormal overheating.
- If the Trigger Mode is not working correctly,
 - Ensure that the CC1 settings on the frame grabber are configured correctly when you use CC1 triggering.
 - Ensure that cable connections are secure when you use external triggering.
- If there is a communication failure between the camera and user's computer,
 - Ensure that the Camera Link cable connections are secure.
 - Ensure that you have configured a frame grabber in your computer and the camera is connected to the frame grabber correctly.

Appendix A. Field Upgrade

You can upgrade the MCU, FPGA and XML file of the camera by following the procedure below.

1. Run the Configurator and then click the Configurator Plus window > Tools > Device Maintenance to open the Device Maintenance window.
2. Select the PKG tab, click the [...] button of the File Path item's left, select the MCU, FPGA or XML upgrade file, and then click the Download button.

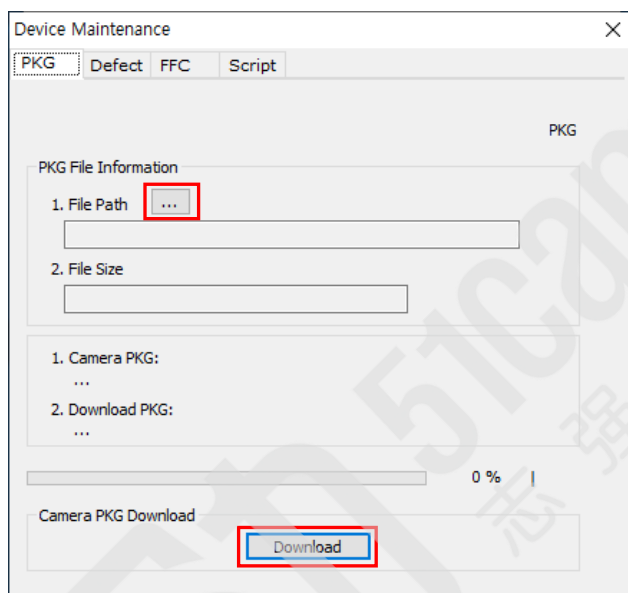

3. The camera begins downloading the upgrade file and the downloading status is displayed at the bottom of the window.
4. After completing the download, click the OK button to close the confirmation.

Appendix B. LUT Download

You can create LUT data in two different ways; by adjusting the gamma values on the gamma graph provided in the program and then downloading the data or by opening a CSV file (*.csv) and then downloading the data.

B.1 Gamma Graph Download

1. Run Vieworks Imaging Solution 7.X and click the Configure button to display the window as shown below. Select the LUT tab, and then select Luminance from the Type dropdown list.
2. Set a desired value in the Gamma input field and click the **Apply** button.

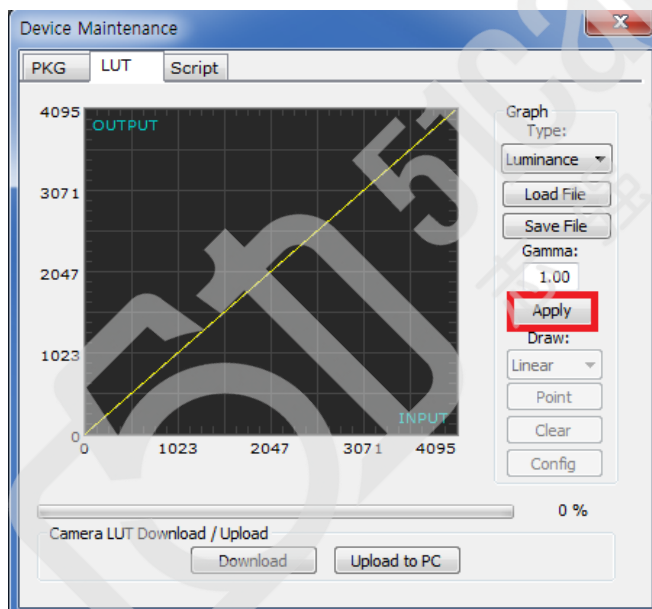

3. Click the **Download** button to download the gamma values to the camera.

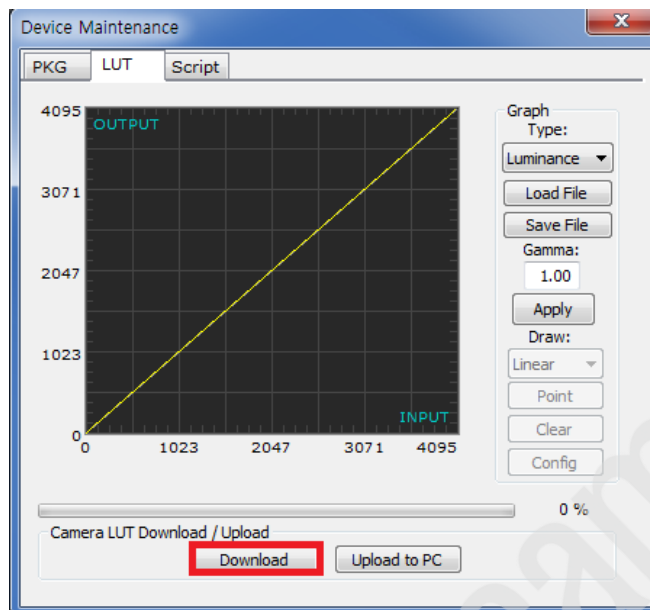

4. After completing the download, click the **OK** button to close the confirmation.

B.2 CSV File Download

1. Create the LUT table in Microsoft Excel format as shown in the left picture below and save as a CSV file (*.csv). The picture in the right shows the created file opened in Notepad. Once the file has been created completely, change the .csv file extension to .lut. Keep in mind the following rules when creating the file.

- Lines beginning with ':' or '--' are treated as notes.
- Based on the input values, make sure to record from 0 to 4095.

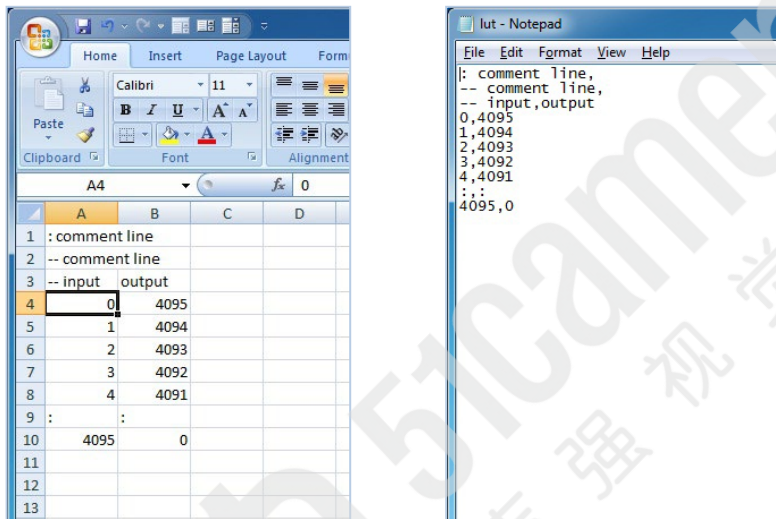

- Run Vieworks Imaging Solution 7.X and click the Configure button to display the window as shown below. Select the LUT tab, select Luminance from the Type dropdown list, and then click the **Load File** button.

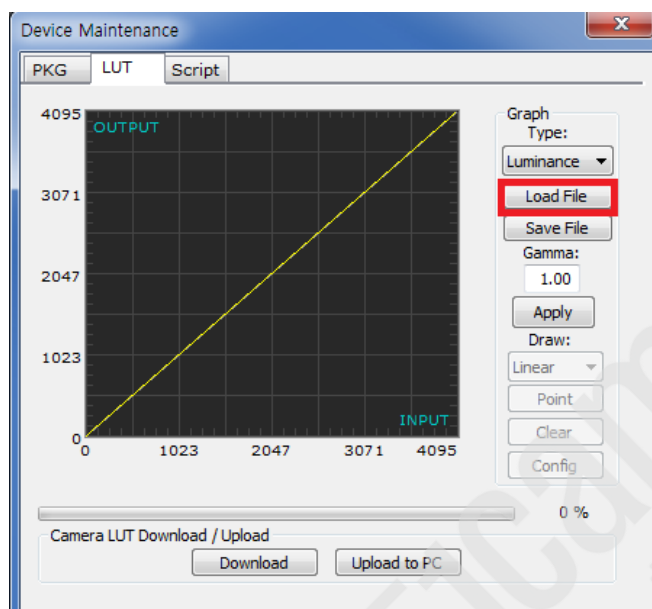

- Search and select the created LUT file and click the **Open** button.

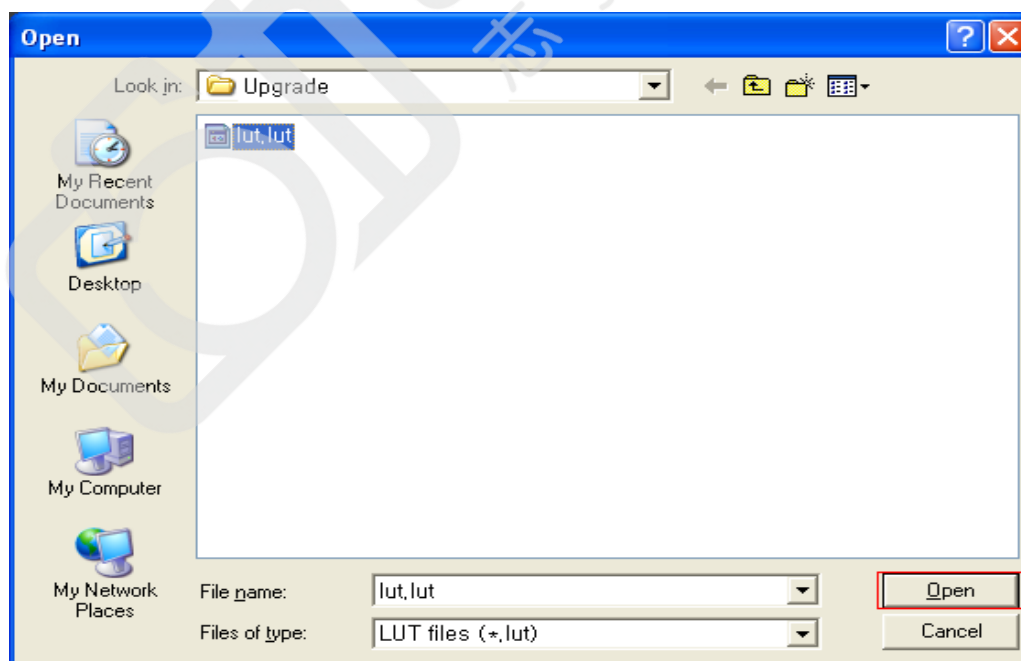

- Click the **Download** button. After completing the download, click the **OK** button to close the confirmation.

Appendix C. Index

4

4-pin connector.....31

6

6-pin connector.....30

A

acquisition control.....33

Acquisition Mode parameter33

Acquisition Start command.....33

Acquisition Stop command.....33

any edge.....36

application.....6

Areascan mode42

B

back panel.....28

Backward parameter.....44

Black Level auto-adjustment41

BlackLevelCalibrationAuto41

block diagram22

C

camera ON&OFF 77

camera's temperature, parameters69

color camera's pixel formats 48

Configurator..... 6

connecting a camera..... 26

CXP connector 28, 29

D

dimension 24

direction input..... 32

downloading Vieworks Imaging Solution 27

downloading VIS..... 27

DSNU data, generation60

Dual Band..... 50

E

Effective Data ROI, determination..... 49

external trigger signal..... 37

F

falling edge	36
Fixed Pattern Noise.....	64
Forward parameter	44
FPN	64
FPN coefficients	64
FPN correction.....	64
Free-Run.....	34

G

gain value, setting	55
generating line start trigger signals.....	34

H

HDR image	53
HDR-image acquisition	53
heat dissipation	25
Hirose	30, 31
Hirose 4-pin connector	31
Hirose 6-pin connector.....	30
housing.....	25

I

inputting information of user's choice.....	77
---	----

L

LED status	69
Line 1 parameter	44
line rate for each model.....	40
Line0 signal.....	34
Linescan mode.....	42, 43
LinkTrigger0 trigger signal	34
Lookup Table.....	58
LUT.....	58

M

monochrome camera's pixel formats	48
mounting	25

N

number of Integration Stage.....	43
number of TDI Stage	43

O

offset to pixel.....	55
offset value, setting	55
OpticalBlackClampCalibration	41

P

preface	3, 6
PRNU	62
product.....	6

Q

quantum efficiency	23
--------------------------	----

R

reset physically	77
rising edge	36

S

scan direction of an image sensor	44
schematic diagram	32
sensor structure	50
signal period of trigger	38
Spatial Correction.....	51
specification.....	21
strobe output	32

T

Target Level AUTO.....	63
TDI Stage parameter	43
Trigger Activation parameter	36
trigger input.....	32
Trigger Mode parameter	34
Trigger Selector parameter	34
Trigger Source parameter	36

V

Vieworks Imaging Solution download	27
VIS	27
VIS installation	27
VT-9K5X2 specification.....	21
VT-9K5X2-H550I-256 specification	21

X

XML parameter

BinningHorizontal	47
BinningHorizontalMode	47
BinningSelector	47
BinningVertical	47
BinningVerticalMode	47
BlackLevelCalibrationAuto	56
BlackLevelSelector	56
CounterAndTimeControl	75, 76
CounterDuration	75
CounterEventActivation	75
CounterEventSource	75
CounterReset	75
CounterResetSource	75
CounterSelector	75
CounterStatus	75
CounterValue	75
CounterValueAtReset	75
DataRoiHeight	49
DataRoiOffsetX	49
DataRoiOffsetY	49
DataRoiSelector	49
DataRoiWidth	49
Device Reset	77
DeviceScanType	42
DeviceTemperature	69
DeviceTemperatureSelector	69
DeviceUserID	77
DigitalIOControl	66
DSNUCoefficient	64
DSNUCoefficientApply	64
DSNUDataGenerate	60
DSNUDataGenerateAll	60
DSNUDataLoad	60
DSNUDataSave	60
DSNUDataSelector	60
FallingEdge	75
FixedPatternNoise	49
FPNCoefficientsControl	64
FrameActive	66
GainSelector	56
GreyDiagonalRamp	70
GreyDiagonalRampMoving	70
GreyHorizontalRamp	70
Line 0	66
Line 1	66
LineActive	66
LineActive, (CounterEventSource)	75
LineInverter	66
LineSelector	66
LineSource	66
LineTrigger0	75
Luminance	59
LUTControl	59
LUTEnable	59
LUTIndex	59
LUTSelector	59
LUTValue	59
Mainboard	69
OffsetX	45
OffsetY	45
OpticalBlackClamp	57
OpticalBlackClampWeight	57
PixelFormat	48
PRNU Selector	62
PRNUCoefficient	64
PRNUCoefficientApply	64
PRNUCorrection	62
PRNUDataGenerate	62
PRNUDataLoad	62
PRNUDataSave	62
PRNUTargetLevel	62
PRNUTargetLevelAUTO	62
ReverseX	73
RisingEdge	75
ROI setting	45
Scan Direction	44
SensorSpecific	70
TestPattern	70
Timer0Active	66
TimerDelay	76
TimerDuration	76
TimerReset	76
TimerSelector	76
TimerTriggerActivation	76
TimerTriggerSource	76
Trigger Ratio	39
TriggerRescalerFilter	39
UserDefault	78
UserOutput0	66
UserOutputValue	66
UserSet1	78
UserSet2	78
UserSetControl	78
UserSetLoad	78
UserSetSave	78
UserSetSelector	78

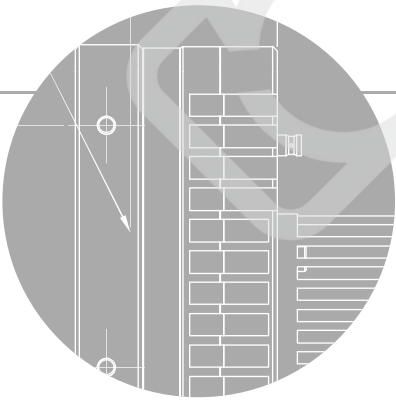
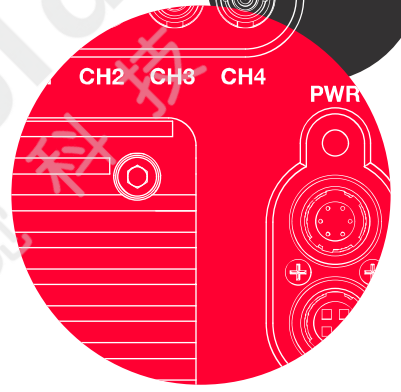
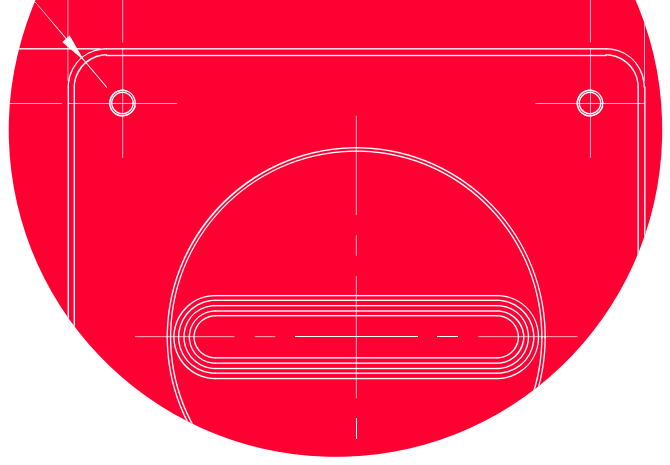

Vieworks Co., Ltd.

41-3, Burim-ro, 170beon-gil,
Dongan-gu, Anyang-si, Gyeonggi-do
14055 Republic of Korea

Tel: +82-70-7011-6161

Fax: +82-31-386-8631

<http://vision.vieworks.com>

vision@vieworks.com