

VC-12MX-M/C 65H

High Speed & High Resolution CMOS Digital Camera
with CoaXPress Interface

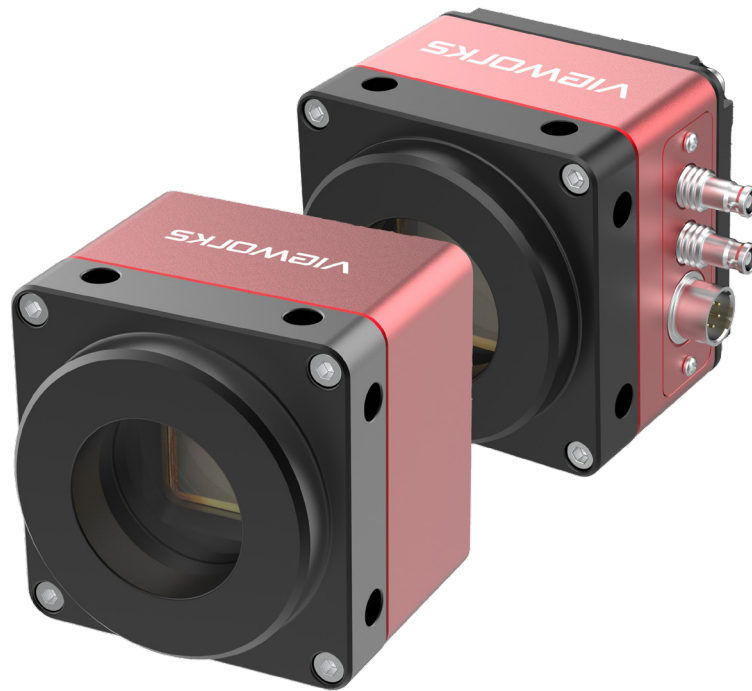

The VC-12MX-65 cameras, the latest members of industrial proven VC series, are based on the latest CMOS global shutter imagers. The cameras feature 12 megapixel resolution with frame rates of up to 65 fps. These combinations of resolution, frame rate, and global shutter set a new standard for Industrial, Scientific, and Surveillance digital imaging applications. Customers in the industrial market can take advantage of common coax cabling to transmit images at rates and distance above and beyond previous standards. With these cameras, image data can be transmitted at up to 6.25 Gbps using a single coaxial cable and up to 12.5 Gbps using two cables. These high speed and high resolution models are ideal for wide range of demanding applications including PCB and semiconductor inspections. For efficiency, Vieworks provides this amazing product in two different types, the straight type and the right-angle type, with the same specification.

VIEWORKS

vision.vieworks.com

VC-12MX-M/C 65 H

High Speed & High Resolution CMOS Digital Camera with CoaXPress Interface

Main Features

- 12 Megapixel Resolutions
- High-speed Progressive Scan CMOS Imager
- Global Shutter CMOS Technology
- CoaXPress Interface up to 64.6 fps at 12.5 Gbps using 2 CH
- Flat Field Correction
- Low Noise with Optimized Heat Treatment

Applications

- PCB Inspection
- Semiconductor Inspection
- 3D Inspection
- High-end Surveillance

Specifications

Model	VC-12MX-M/C 65 H (Both Straight Type and Right-angle Type)	
Resolution (H × V)	4,096 × 3,000	
Sensor	Sony IMX253	
Sensor Size(Diagonal)	17.6 mm	
Sensor Type	High Speed CMOS Image Sensor	
Pixel Size	3.45 μm × 3.45 μm	
Interface	CXP-6 × 2 (Micro BNC)	
Max. Frame Rate	64.6 fps	
Exposure Time (1 μs step)	1.51 μs – 60 s	
Partial Scan (Max. Speed)	3413.7 fps at 4 Lines	
Pixel Data Format	8 bit	
Electronic Shutter	Global Shutter	
Gain Control	Analog: ×1 – ×8, Digital: ×1 – ×32	
Black Level Control	0 – 15 LSB at 8 bit	
Trigger Synchronization	Free-Run, Timed, Trigger Width	
Dynamic Range	65 dB	
Dimension,	Straight Type	50 mm × 50 mm × 44 mm, 184 g (C-mount)
Weight	Right-angle Type	50 mm × 50 mm × 45 mm, 198 g (C-mount)
Temperature	Operating: 0°C ~ 40°C (Housing: 10°C ~ 50°C), Storage: -40°C ~ 70°C	
Lens Mount	C-mount	
Power	External	11 ~ 24 V DC, Typical 6.5 W
Compliance	CE, FCC, KC	
API SDK	Vieworks Imaging Solution 7.X	

VC-12MX-M/C 65 H

High Speed & High Resolution CMOS Digital Camera with CoaXPress Interface

Spectral Response

* The sensitivity data may not match the measurement on the finished product necessarily because it is measured based on the wafer.

Monochrome *

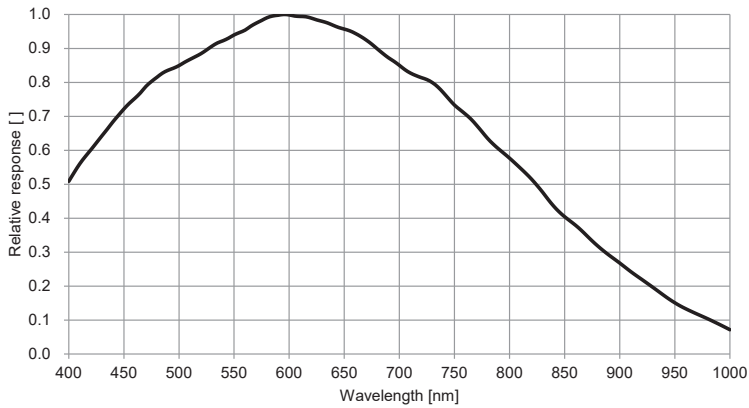

Color *

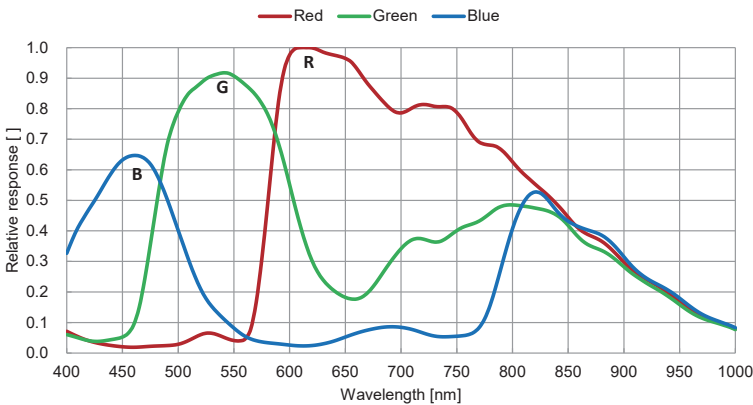

Ordering Scheme

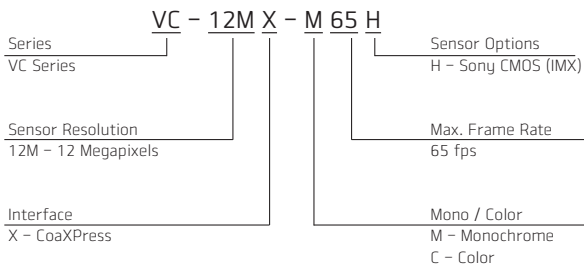

Connector Specification

Power / Control



- 1: +12V DC
- 2: Trigger IN+
- 3: Trigger IN-
- 4: Strobe OUT+
- 5, 6: DC Ground (HR10A-7R-6PB)

Data Transfer / Communications

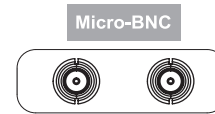

CH1: Master Connection (75 Ω, Micro BNC)

Connectors on camera body

VC-12MX-M/C 65 H

High Speed & High Resolution CMOS Digital Camera with CoaXPress Interface

Mechanical Dimensions: Straight Type

Unit: mm

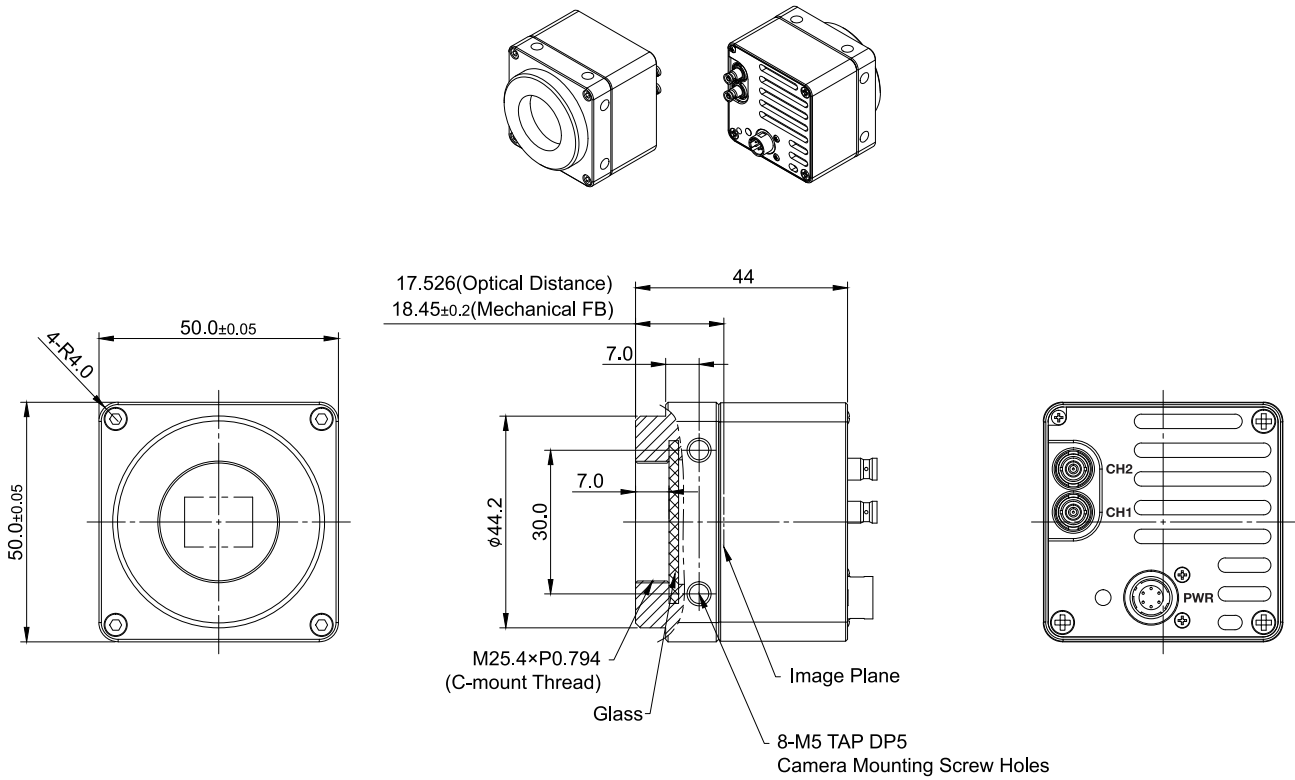

Mechanical Dimensions: Right-angle Type

Unit: mm

