

VC-51MX2-M/C30I00

Ultra High Resolution CMOS Digital Camera



CoaXPRESS®

The VC-51MX2-M/C30I00 is a new 51-megapixel CoaXPRESS camera based on GMAX4651, the latest CMOS image sensor technology, from Gpixel. It offers up to 30 frames per second at 8,416 × 6,032 resolution. The camera comes with the next generation CoaXPRESS 2.0 (CXP-12) interface, delivering up to 50 Gigabits per second over 4 coaxial cables. With advanced uniformity and high-speed image processing capabilities, it sets a new standard for high-performance digital imaging in industrial, scientific, and surveillance fields. This camera is ideal for demanding applications such as FPD, PCB, and semiconductor inspections.

VIEWORKS

vision.vieworks.com

VC-51MX2-M/C30I00

Ultra High Resolution CMOS Digital Camera

Mechanical Dimensions

Unit: mm

VC-51MX2 (FAN)

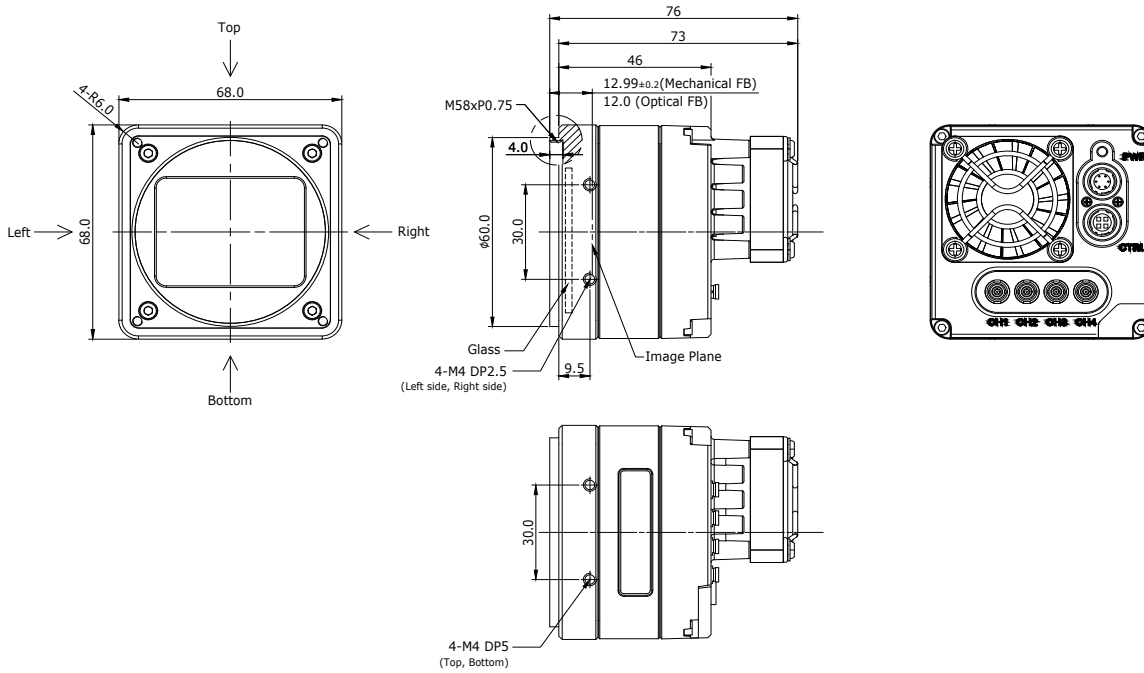

VC-51MX2 (Heatsink)

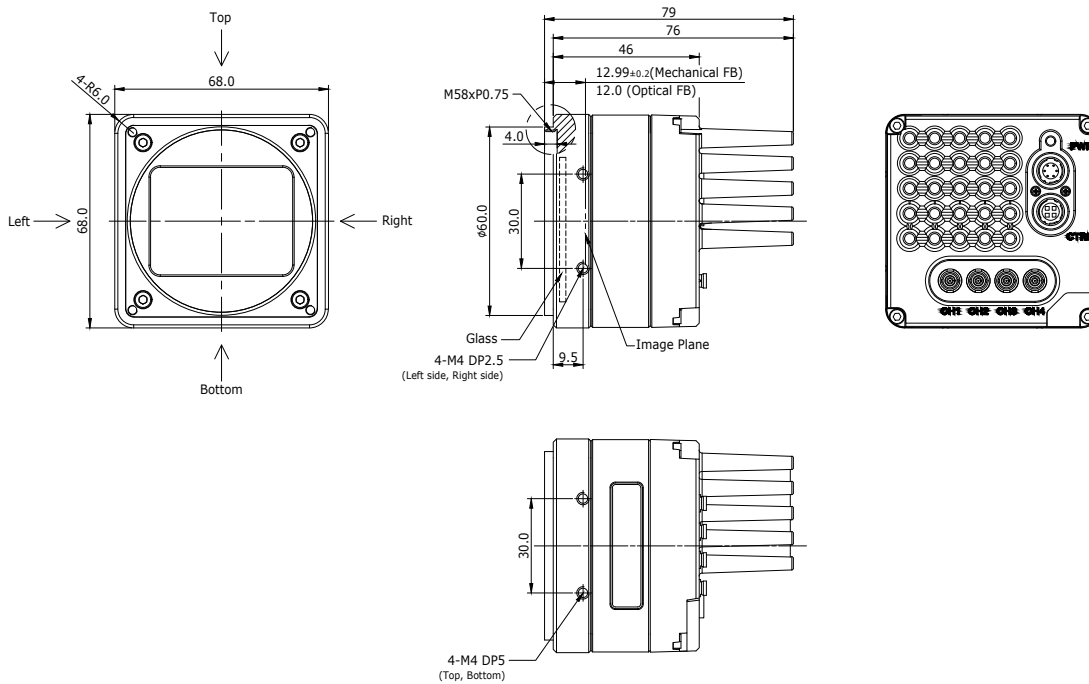

VC-51MX2-M/C30I00

Ultra High Resolution CMOS Digital Camera

Main Features

- 51-Megapixel Resolution
- CoaXPress 2.0 Interface up to 30 fps at 50 Gbps using 4 Channels
- Power over CoaXPress (PoCXP)
- Global Shutter CMOS Technology
- DSNU and PRNU Correction
- Flat Field Correction
- Defective Pixel Correction

Applications

- Flat Panel Display Inspection
- Electronics Inspection
- Semiconductor Inspection
- Document / Film Scanning

Specifications

Model		VC-51MX2-M/C30I00
Resolution (H × V)		8,416 × 6,032
Sensor		GMAX4651
Sensor Size (Diagonal)		38.8 mm × 27.8 mm (47.63 mm)
Pixel Size		4.6 μm × 4.6 μm
Interface		CoaXPress 2.0 (CXP-6/10/12)
Max. Frame Rate (8 bit)		30.3 fps
Exposure Time (1 μs step)		1 μs to 20 s
Binning		Horizontal and Vertical Independent: ×1, ×2, and ×4(Mono Only)
Pixel Data Format	Monochrome	8/10/12 bit
	Color	RG Bayer 8/10/12 bit
Electronic Shutter		Global Shutter
Exposure Mode		Timed, Trigger Width
Dynamic Range		65 dB at 12 bit
Gain Control	Analog	×3.5 to ×5
	Digital	×1 to ×32
Black Level Control		0 to 256 LSB at 12 bit
Dimension / Weight	FAN	68 mm × 68 mm × 76 mm, 0.41kg
	Heatsink	168 mm × 68 mm × 79 mm, 0.41kg
Temperature		Operating: 0°C to 40°C, Storage: -40°C to 70°C
Trigger Synchronization		Free-Run, Hardware Trigger, Software Trigger, and CXP
External Trigger		3.3 V to 24.0 V, 10 mA, Logical Level Input, Optically Isolated
Software Trigger		Asynchronous, Programmable via Camera API
Lens Mount		M58 mount, F-mount adapter, or custom mount available upon request
Power	External	11 to 24 V DC
	Dissipation	Typ.11.5 W
	PoCXP	24 V DC, Minimum 2 of PoCXP cables required
Compliance		CE, FCC, KC
API SDK		Vieworks Imaging Solution 7.X

VC-51MX2-M/C30I00

Ultra High Resolution CMOS Digital Camera

Spectral Response

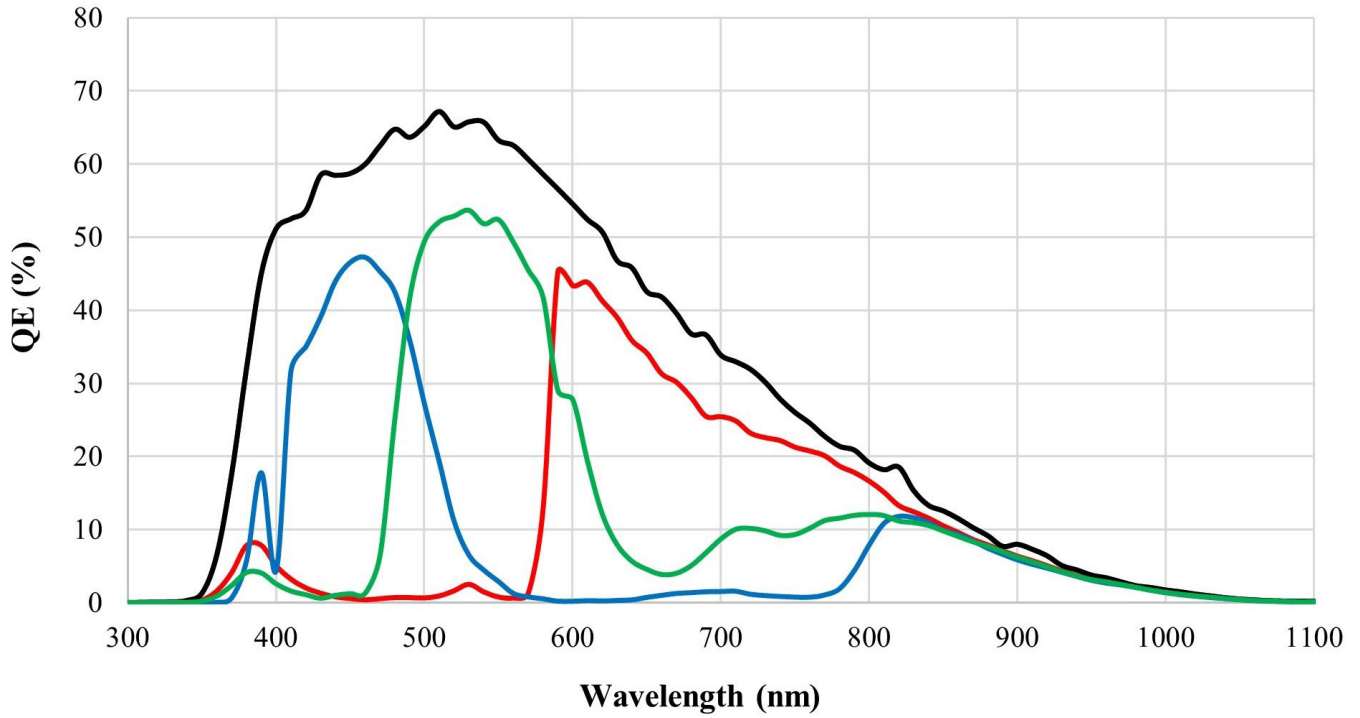

Ordering Scheme

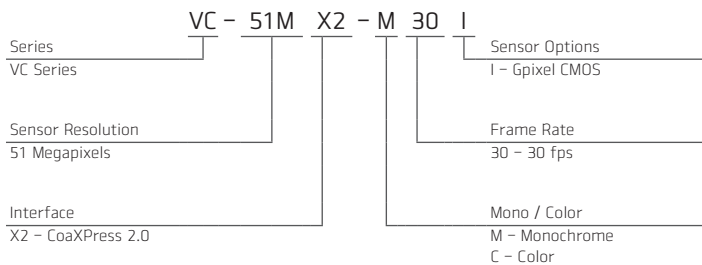

Connector Specification

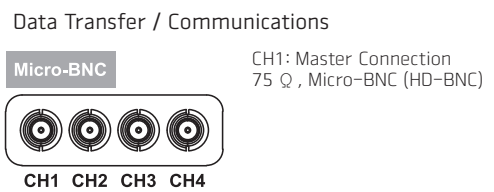
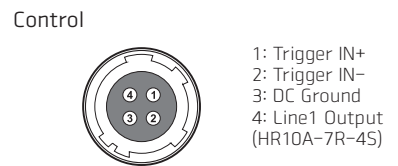
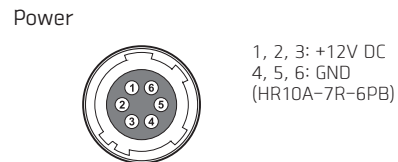

Connectors on camera body