

Rev No.	Description	Date	Name

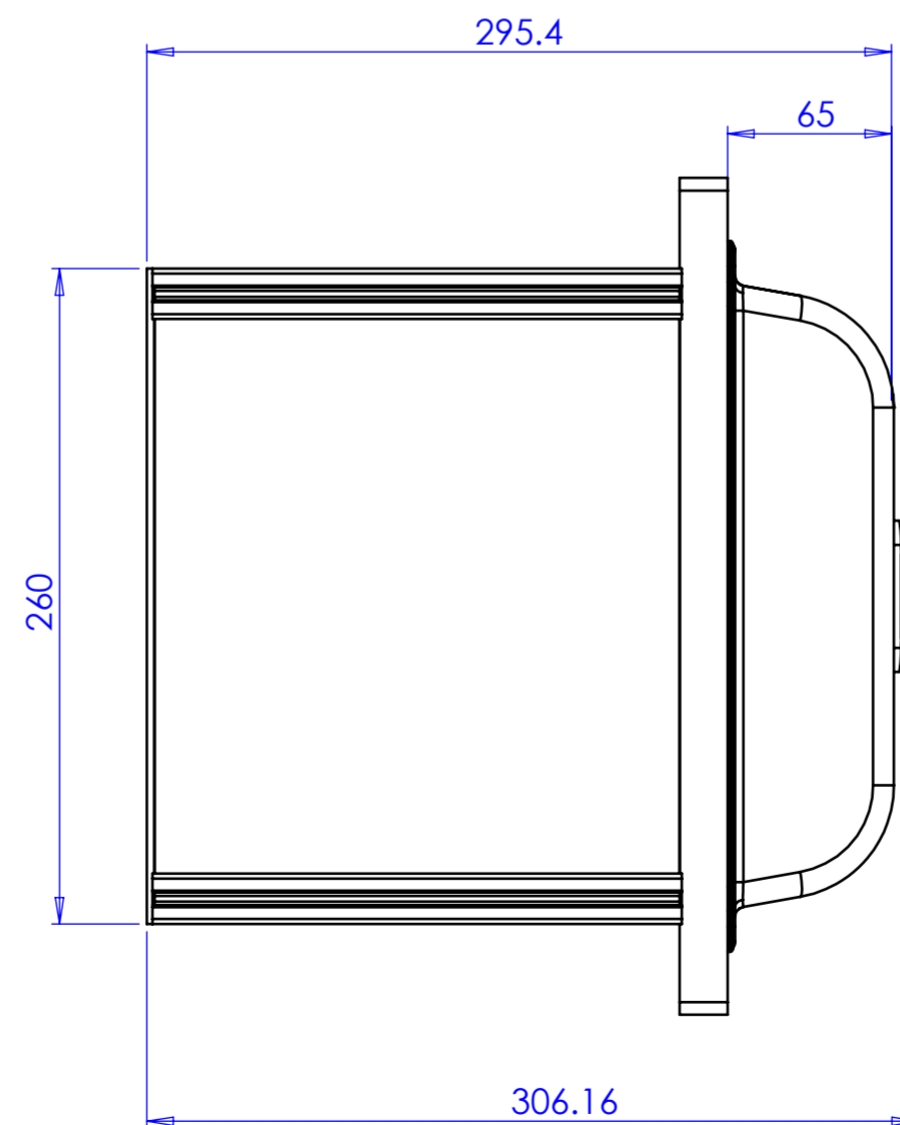
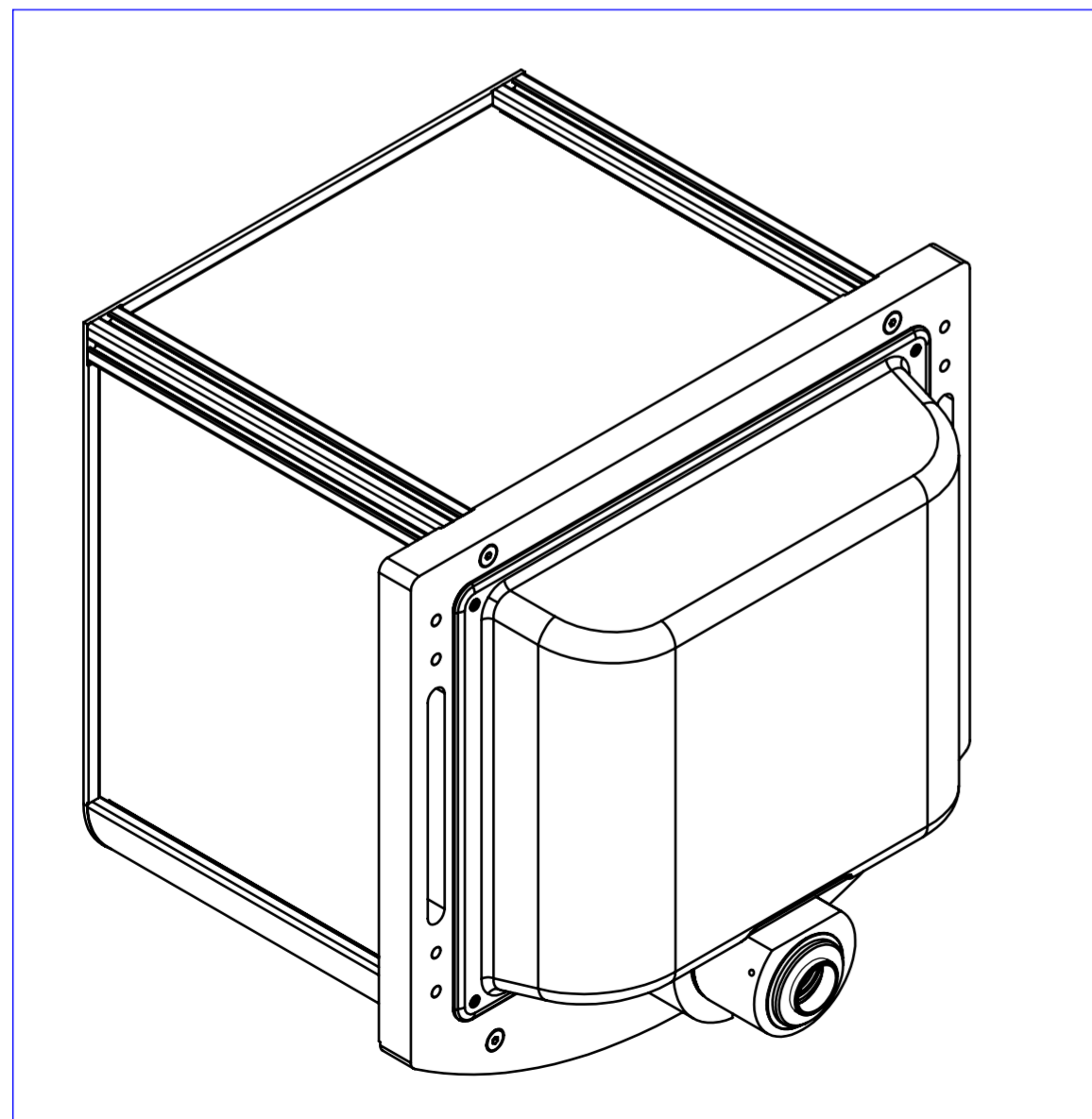
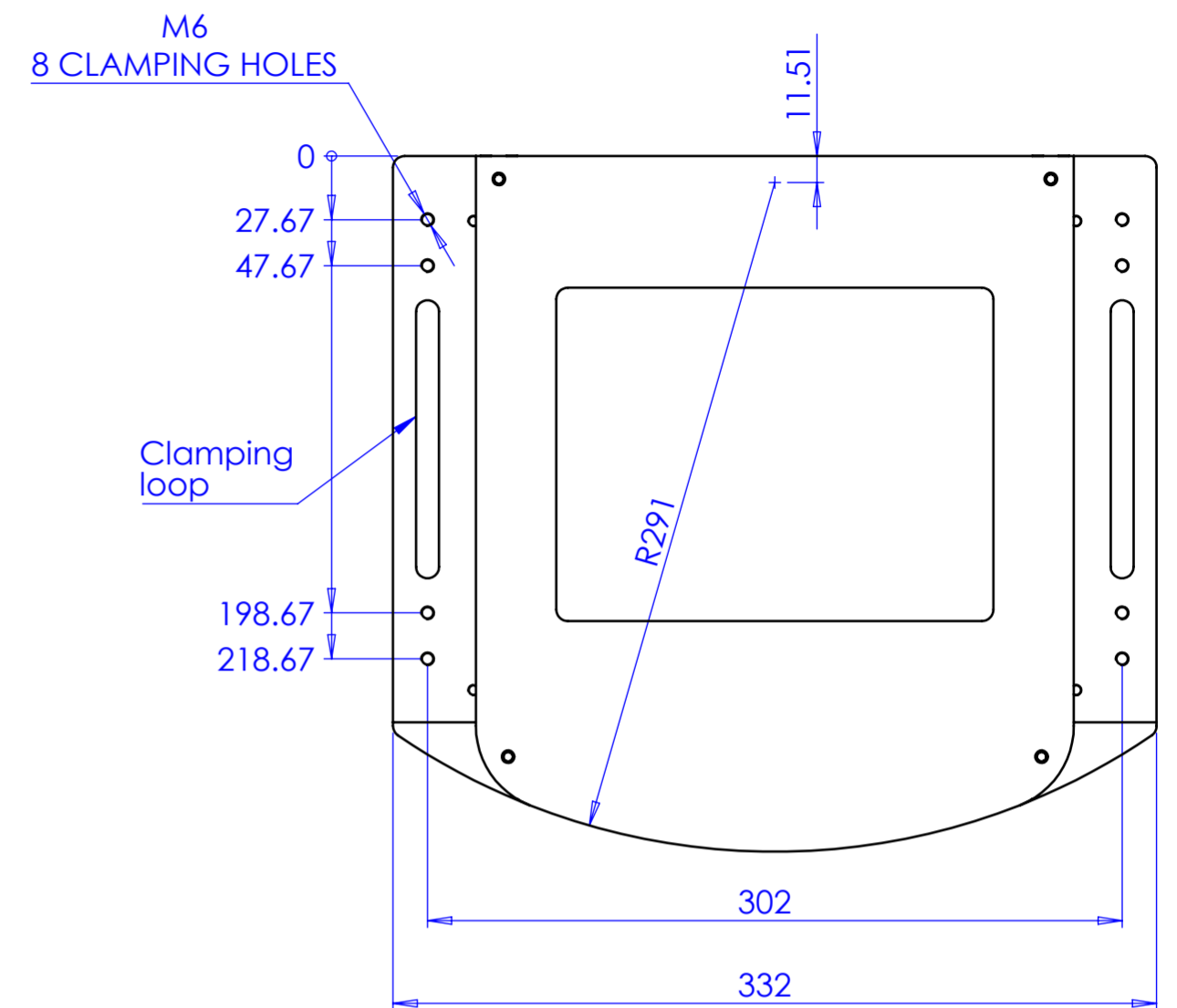
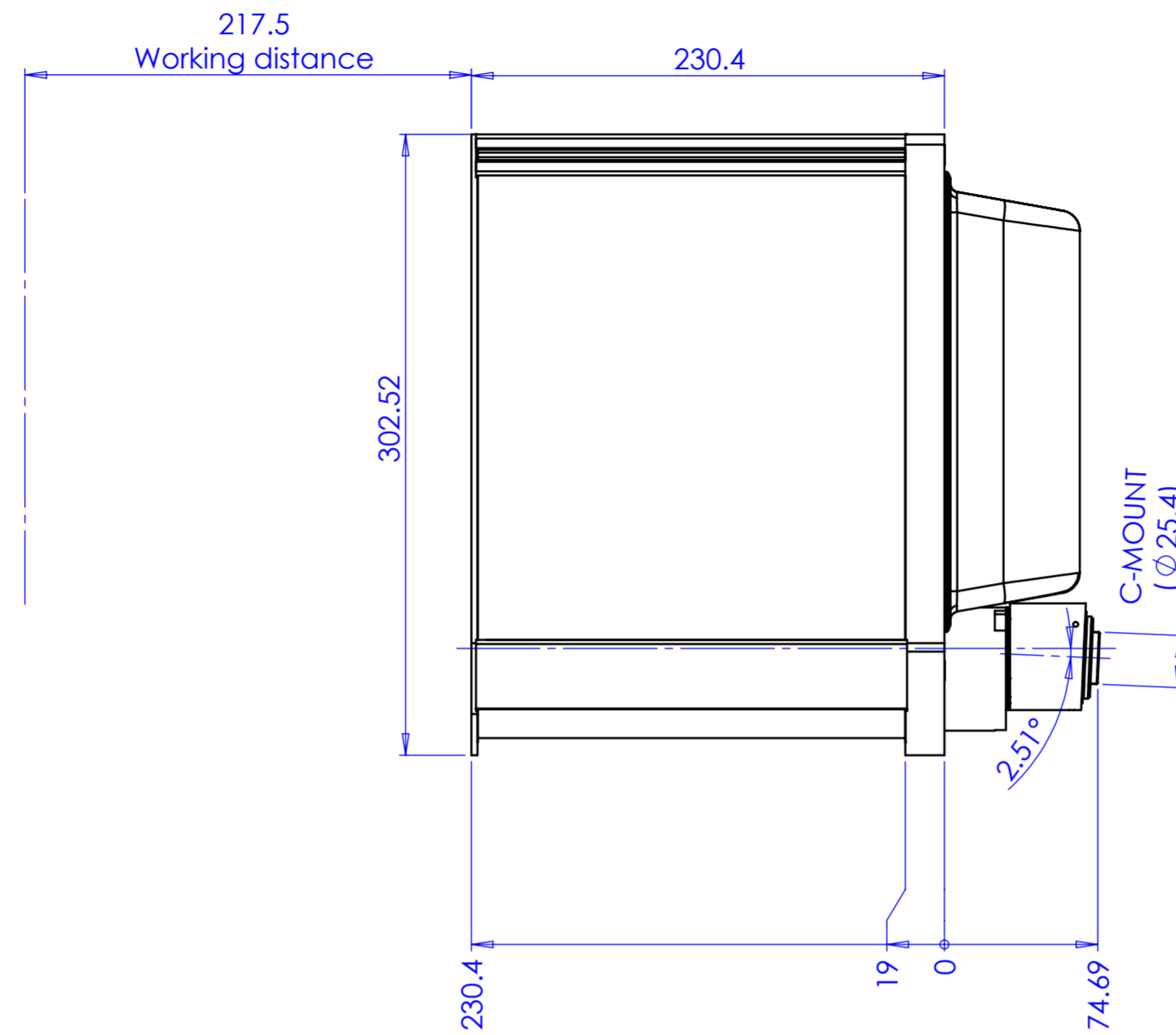
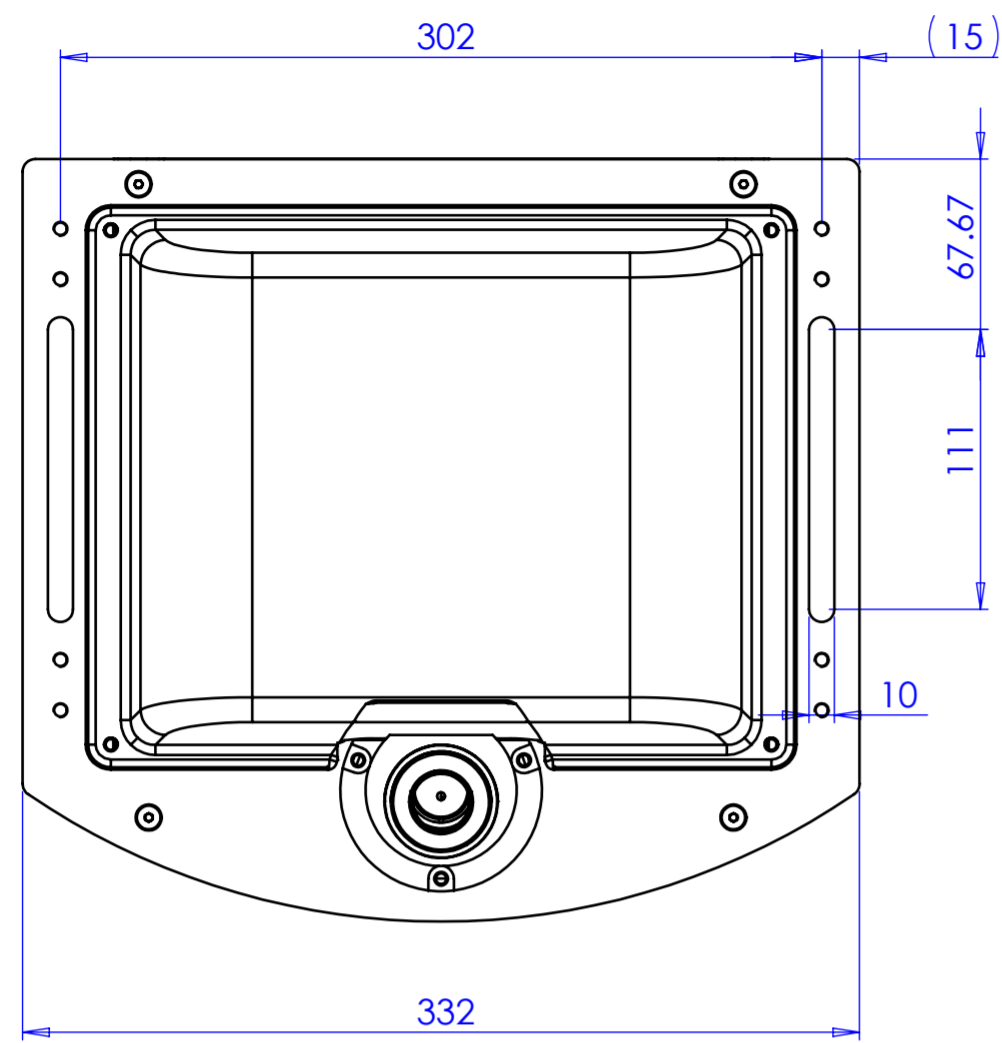

Material	N.A.	Mass	g	Scale	1:3					
Surface treatment	Black Satin Anodizing	Part No.	CO27586							
Geometrical tolerance (ISO 2768-2)	Class	K	Undimensioned bevels	0.5x45°	Description					
Linear tolerance (ISO 2768-2)	Class	m	Undimensioned radii	R 0.5	TCCP12144					
0.5	>3+	>6+	>30+	>120	>400+	>1000	>2000	>4000	Drawing No.	Sheet
+3	6	30	120	+400	1000	+2000	+4000	DP 27586-A		
±0.1	±0.1	±0.2	±0.3	±0.5	±0.8	±1.2	±2	Designed 24/05/2018 Ccharly		
OPTO ENGINEERING S.r.l.			Date 12/07/2018			Name newbie1			Checked	
OPTO ENGINEERING S.r.l. - Mantova Italy - Tel. +39 0376 699111 - www.opto-engineering.com										

Secret and confidential - All rights reserved - No copy, dissemination or circulation is allowed unless specifically authorized in writing by OPTO ENGINEERING S.r.l. - Any violation shall be legally prosecuted.