

1

2

3

4

D

D

C

C



B

B

A

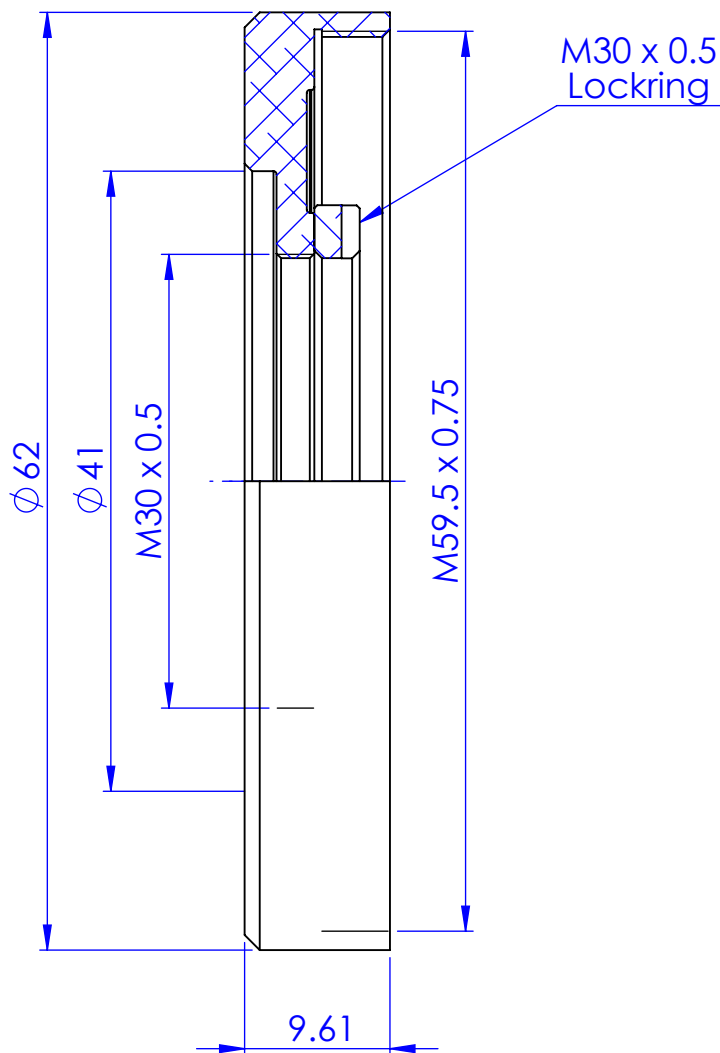
A



Material		N.A.		 		Mass	30 g	Scale	2:1
Surface treatment						Part No.			
						CO33674			
Geometrical tolerance (ISO 2768-2)		Class		K		Undimensioned bevels		0.5x45°	
Linear tolerance (ISO 2768-2)		Class		m		Undimensioned radii		R 0.5	
0.5	>3	>6	>30	>120	>400	>1000	>2000	Description	
±3	6	30	120	400	1000	2000	4000	IPT-AR51-C	
±0.1	±0.1	±0.2	±0.3	±0.5	±0.8	±1.2	±2	Drawing No.	
 OPTO ENGINEERING		Date		Name		Drawing No.		Sheet	
		Designed		05/02/2024		LSpanu		DP 33674-A	
		Drawn		08/02/2024		LSpanu		1/1	
Checked		14/02/2024		Rizzotto		<i>Secret and confidential - All rights reserved - No copy, dissemination or circulation is allowed unless specifically authorized in writing by OPTO ENGINEERING S.p.A. - Any violation shall be legally prosecuted.</i>			
OPTO ENGINEERING S.p.A. - Mantova, Italy - Tel. +39 0376699111 - www.opto-e.com									

1

2

3

4