



5TH November 2014

Innovative optical solutions for pharmaceutical/biomedical industry

M. Castelletti – *Product Manager, biomedical engineer*

Table of contents

1

Who we are

2

Optics and Illumination basis

3

Application Cases

Table of contents

1

Who we are

2

Optics and Illumination basis

3

Application Cases

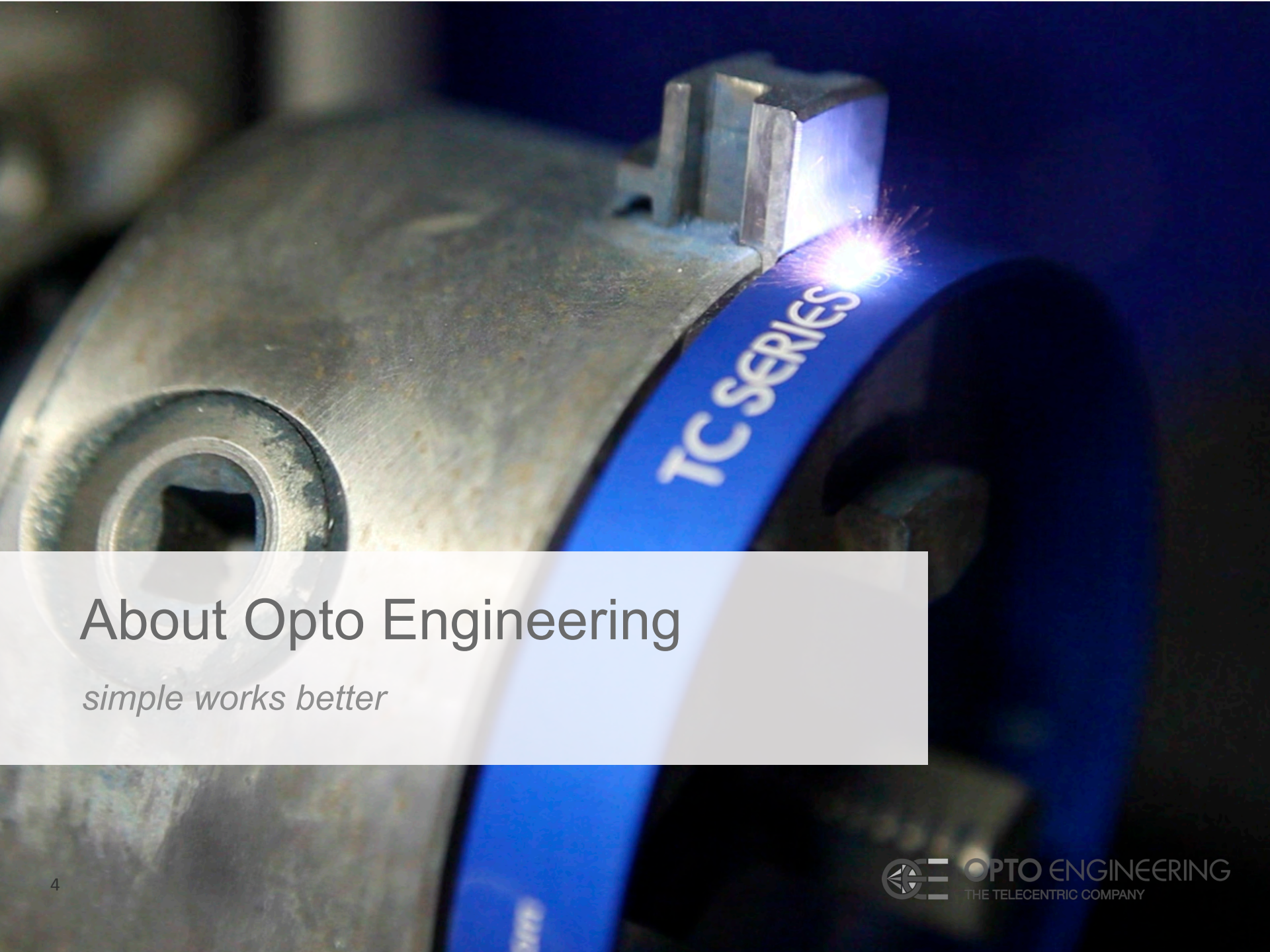

TC SERIES

About Opto Engineering

simple works better

About Opto Engineering

WHO WE ARE

Opto Engineering designs and manufactures optical and illumination systems for the machine vision industry since 2002.

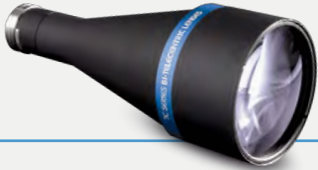

Telecentric

2003



360° optics

2009



Zoom

2011



Illuminators

2014



Global presence

Table of contents

1

Who we are

2

Optics and Illumination basis

3

Application Cases

Introduction

CRITICAL PHARMA BIOMED PARTS



Vials



Syringe

CHALLENGE



RAISE QUALITY



CUT COSTS

COMPLIANCE WITH REGULATIONS

(100% quality inspection)



MACHINE VISION

Introduction

MACHINE VISION SYSTEM – KEY COMPONENTS

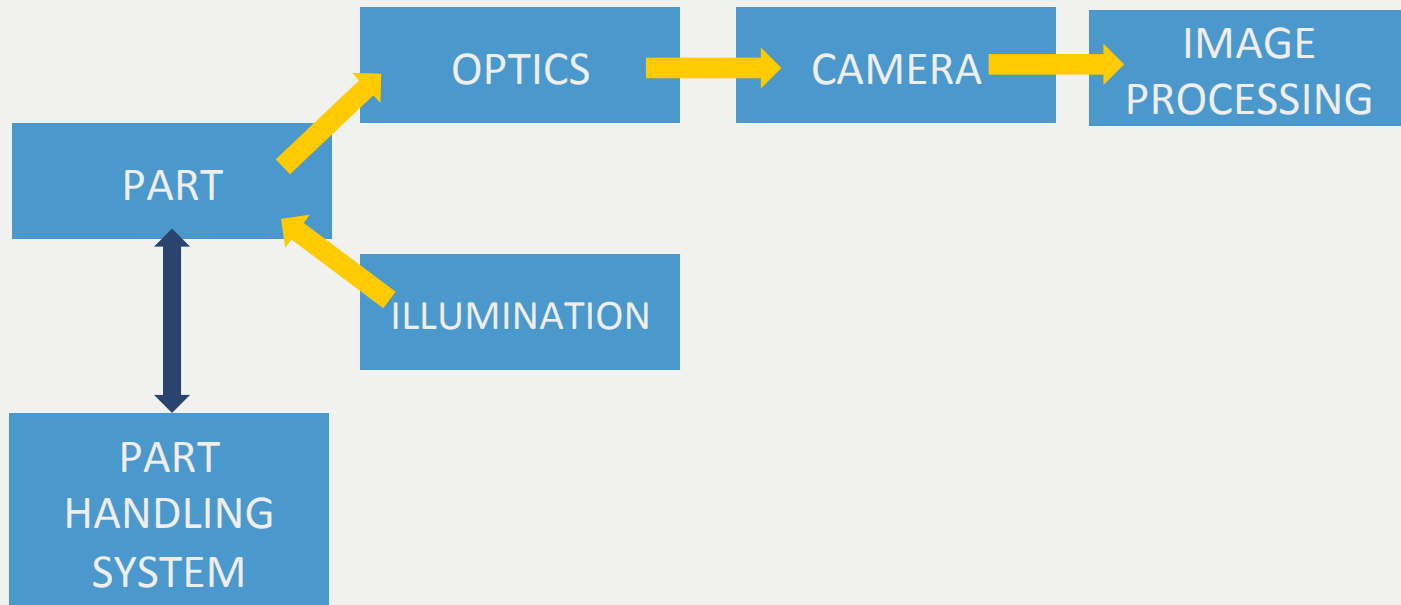

Machine vision systems are like a chain: *only as strong as their weakest link*

Introduction

MACHINE VISION SYSTEM – KEY COMPONENTS

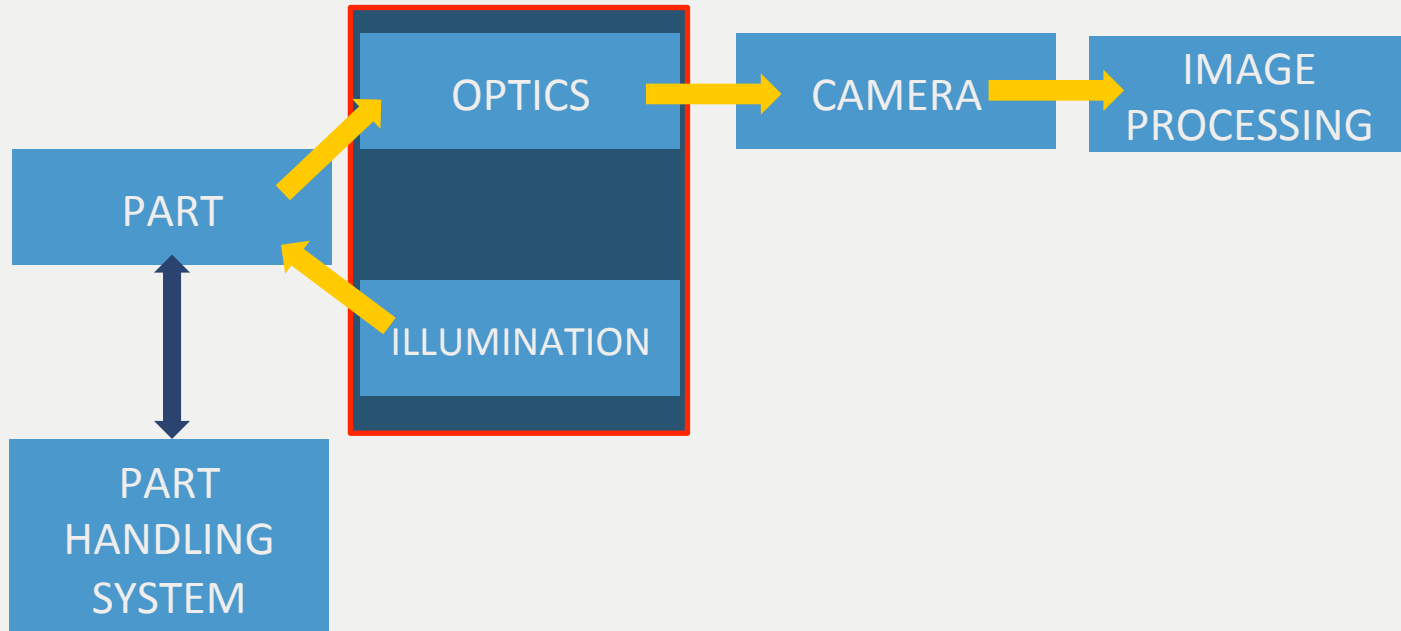

Machine vision systems are like a chain: *only as strong as their weakest link*

IT'S ALL ABOUT LIGHT

Optics and illumination can often be the limiting factor in a system's performance

Optics – basic lens types

ENTOCENTRIC

TELECENTRIC

PERICENTRIC

Optics – basic lens types

ENTOCENTRIC

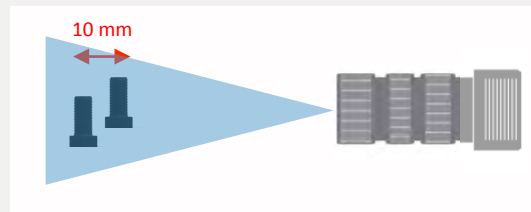
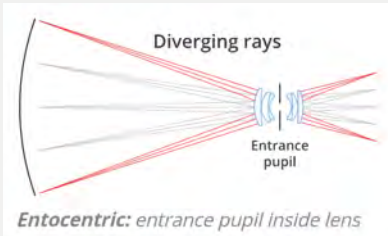

Optics – basic lens types

TELECENTRIC

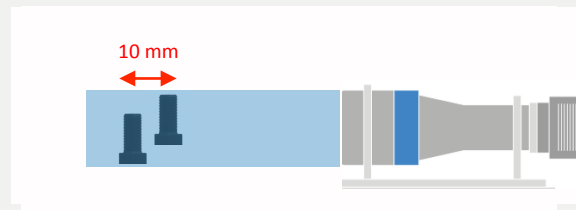
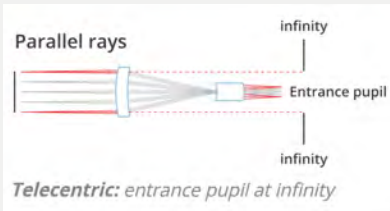

Telecentric lenses are required for any dimensional measurement imaging application

TELECENTRIC

WHEN TELECENTRIC LENSES SHOULD BE USED

- When a thick object (thickness $> 1/10$ FOV diagonal) must be measured
- When different measurements on different object planes must be carried out
- When the object-to-lens distance is not exactly known or cannot be predicted
- When holes must be inspected or measured
- When the profile of a piece must be extracted
- When the image brightness must be very even
- When a directional illumination and a directional “point of view” are required

Optics – basic lens types

PERICENTRIC

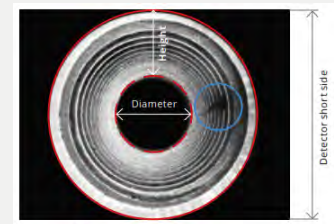
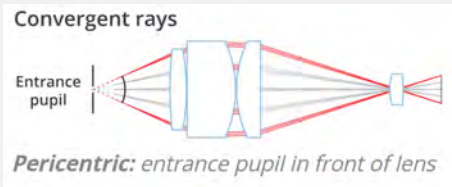

Illumination – basic illumination techniques

FRONT LIGHT ILLUMINATION

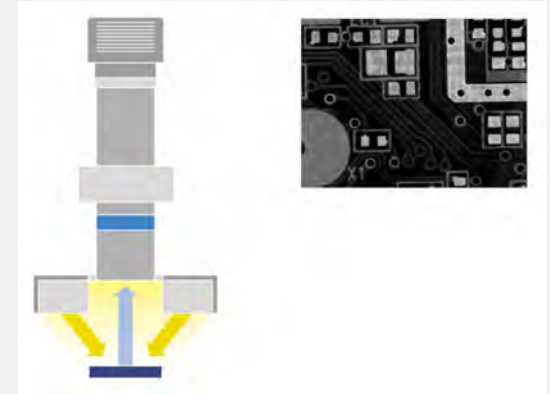
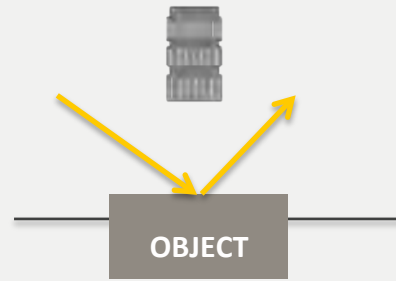

BACK LIGHT ILLUMINATION

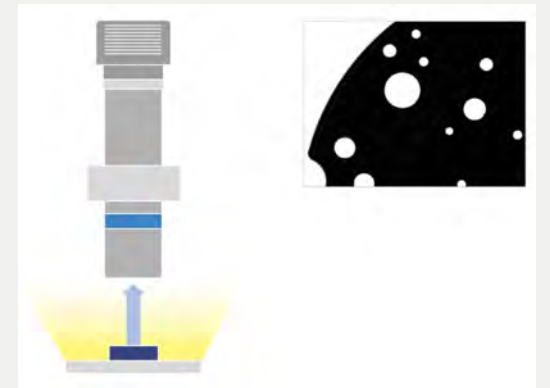
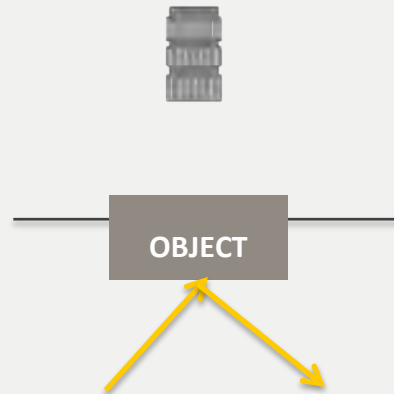

Illumination – basic illumination techniques

FRONT LIGHT ILLUMINATION

BACK LIGHT ILLUMINATION

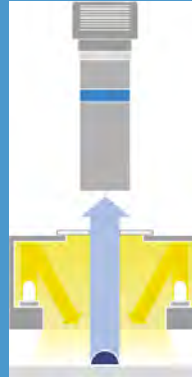

DIFFUSED DOME- Bright field

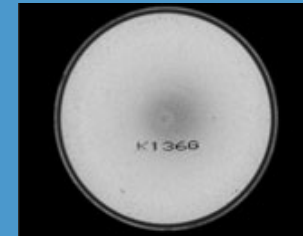

For complex shapes with curved and shiny surfaces



LOW ANGLE RING LIGHTS- Dark field



To enhance surface features or textures

Illumination – basic illumination techniques

FRONT LIGHT ILLUMINATION

BACK LIGHT ILLUMINATION

DIFFUSED BACKLIGHT

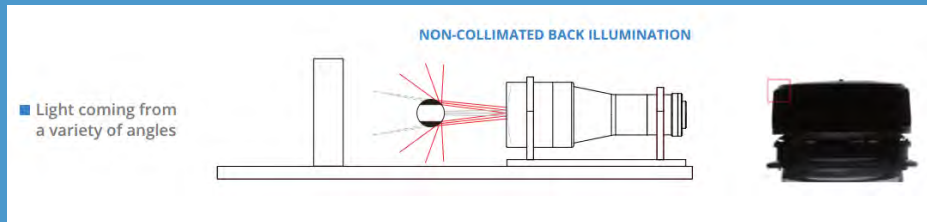

COLLIMATED BACKLIGHT

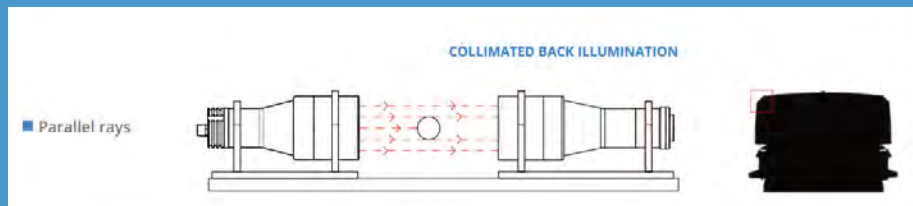

- Border effects removal - Enhanced Field Depth

Table of contents

1 Who we are

2 Optics and Illumination basis

3 Application Cases

Applications – CASE 1

Product: Telecentric lens TC23036 + telecentric illuminator LTCL036-G

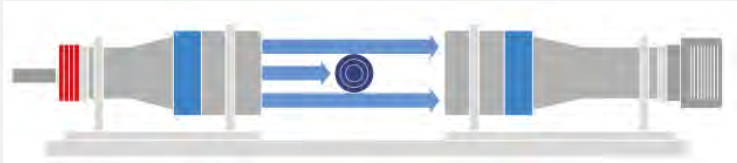

- BI telecentricity
- Nearly zero distortion
- Excellent resolution
- Simple and robust design (fixed aperture)
- Detailed test report with measured optical parameters
- Matching telecentric illuminator

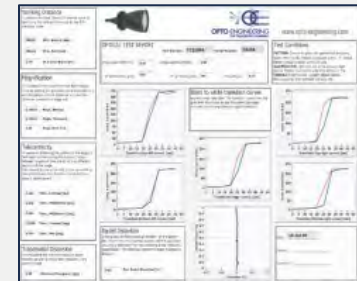

Applications – CASE 1

Product: Telecentric lens TC23036 + telecentric illuminator LTCL036-G

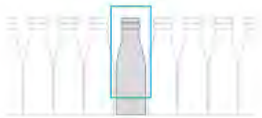
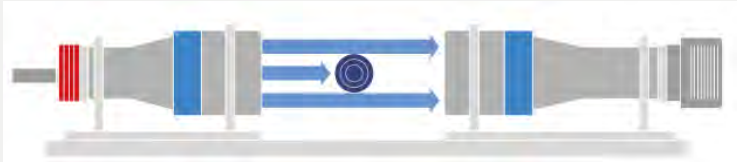

- **High speed** production lines
The high throughput allows for shorter exposure times



- **Silouetting** and for detecting edges and defects
Elimination of blurred edges caused by diffuse reflections

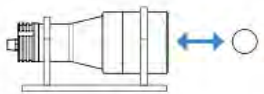

- **Increased distance** between object and illumination source



- **Precision measurements**
where accuracy, repeatability, and throughput are key factors

- **Complete light coupling**
very high signal-to-noise ratio
- **Border effects removal**
collimated rays are typically much less reflected
- **Field depth and telecentricity improvement**
Collimated illumination geometry increases a telecentric lens natural field depth

Applications – CASE 1

Product: Telecentric lens TC23036 + telecentric illuminator LTCL036-G

Application: Glass vials measurement



Diffused lighting

Telecentric lighting



Type of measurements:

- Finish / collar/ cone profile
- Diameter of the neck / cone
- Planarity of the mouth
- Axiality of the neck
- Shoulder angles
- Total length

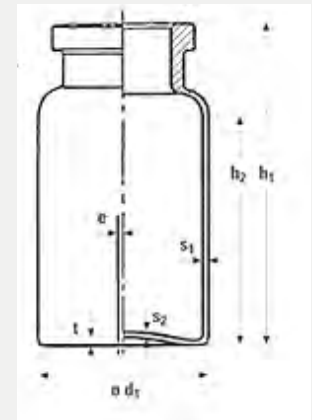

Clear object contours can be seen under telecentric lighting, making accurate measurements of the object possible.

Applications – CASE 2

Product: PCCD012 CATADIOPTRIC LENS

360° imaging of small objects

Parts down to 7.5 mm in diameter can be imaged

Extra wide lateral viewing angle

Object sides viewing angle approaches 45°

Compactness

The lens can be easily held and integrated in any system

Perfect chromatic correction

For RGB camera applications and color inspection



WORKING PRINCIPLE

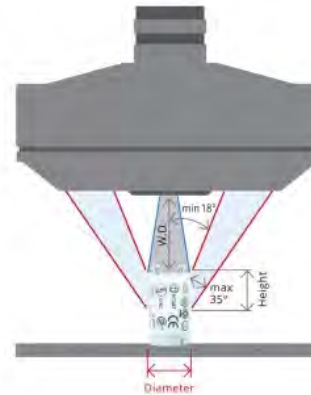

IMAGE



Product: PCCD012 CATADIOPTIC LENS

Application: CHECK FOR CORRECT SEALING OF VIALS (FLIP OFF CAP)

SA10 automatic inspection machine for vials

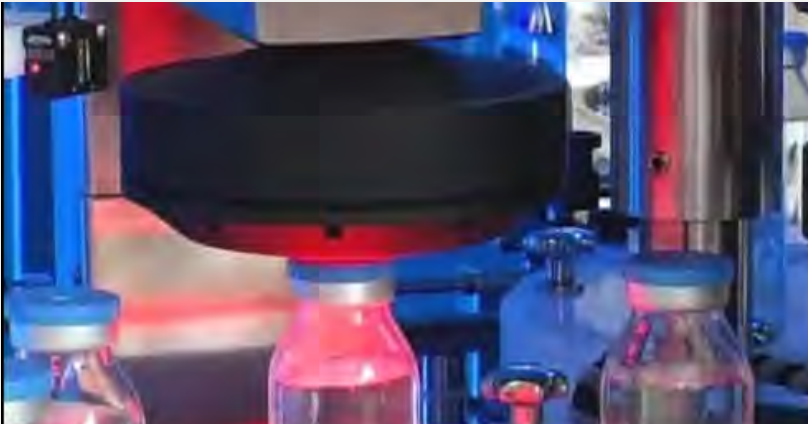

- Production of 6.000 p/H - Totally electronic
- Products are loaded in the machine through baskets.
- Separated in "good" and "reject"



Detection of:

- Stopper absence
- Defective Crimp
- Dents
- Flip Off Deformation
- Wrong Color
- Cap Scratches and Deformation

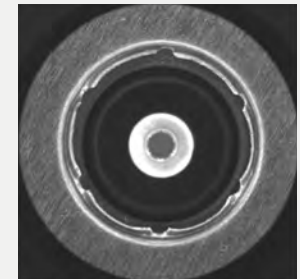

Image courtesy CMP Pharma

Applications – CASE 2

Product: PCCD012 CATADIOPTRIC LENS

Application: Examining the threads of a PET bottle neck preform



OBJECT

IMAGE



Detection of:

- Incomplete thread
- Defective thread
- Oval Shape
- Mouth defects

Applications – CASE 3

Product: TC16M096 Telecentric lens

FOV: 107 mm



- Wide image circle for 8k-5 μ m detectors
- High telecentricity
- Excellent resolution and low distortion
- Simple and robust design for industrial environments
- Detailed test report with measured optical parameters

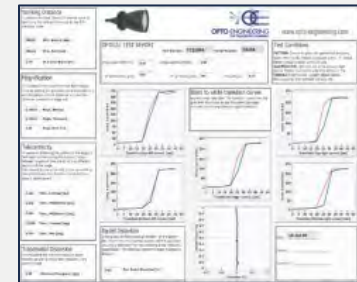

Applications – CASE 3

Product: TC16M096 Telecentric lens

Application: PETRI DISH ANALYSIS



Type of check

- Quantitative and qualitative culture growth
- Colour check for seeding and bacterial growth
- Count and identification of bacterial colonies



TECH SPECS

Camera: Dalsa 4K, Sensor: 4096 x 3 pixels with a pixel size of 10um

Illumination: multiple = ringlight, backlight, side illumination to perform different types of control.

Applications – CASE 3

Product: TC23080

Application: Cell culture

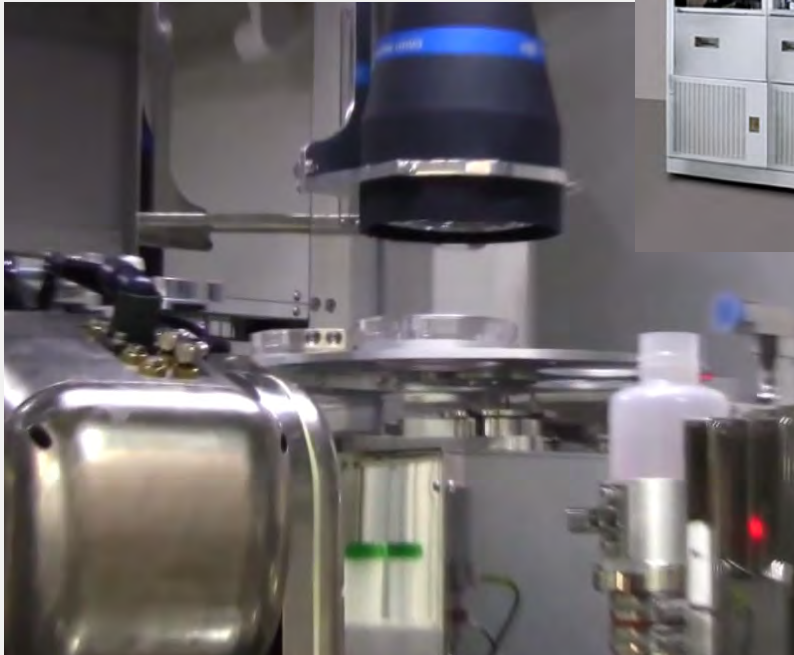

FEATURES:

- Fully automated cell culture procedures
- Displays and automatically records images of cultured cells
- Detect and remove human iPS cells which have begun to differentiate

Opto Engineering TC Lens is used by Nobel Prize Dr. Shinya Yamanaka in its IPS (induced pluripotent stem cells) research

Applications – CASE 4

Product: PCHI023 hole Inspection optics



Perfect focusing of holed objects

Both the walls and the bottom of a cavity are imaged in high resolution

Cavity inspection from the outside

No need to put an optical probe into the hole

Very high field depth

Objects featuring different shapes and dimensions can be imaged by the same lens

Wide viewing angle

Sample surfaces are acquired by the lens under a convenient perspective to clearly display their features

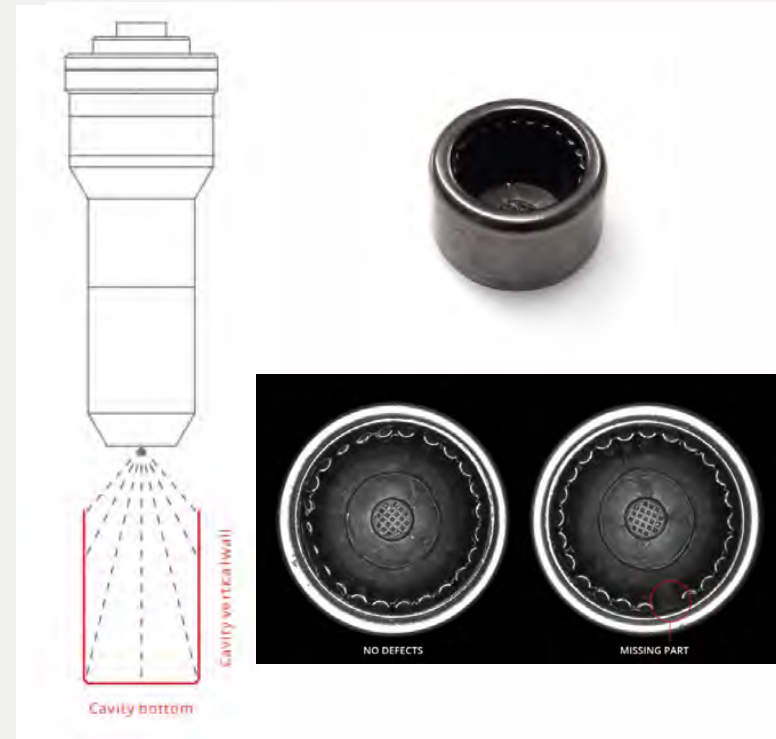

Applications – CASE 4

Product: PCHI023 Hole Inspection optics



Application: Check of aluminium tubes for latex seal integrity

SET UP

IMAGES

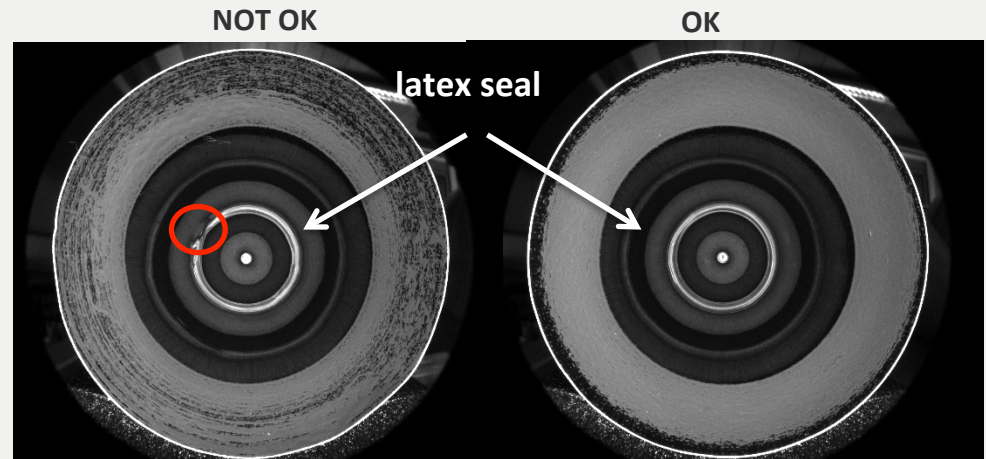
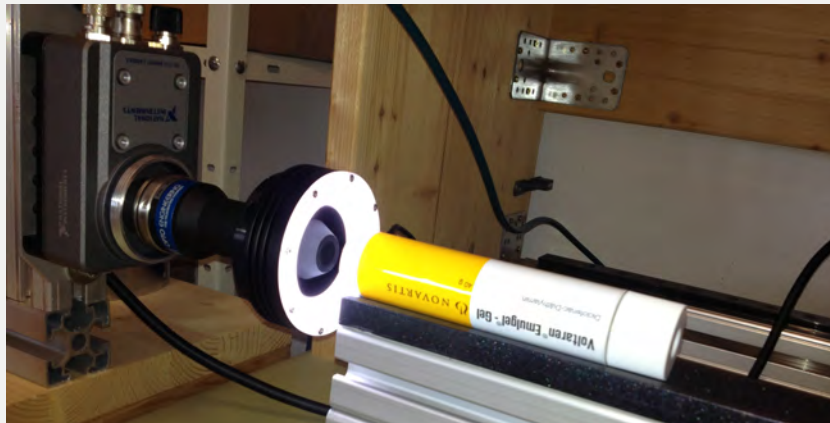

Image courtesy ZIND ENGINEERING

Applications – CASE 5

PRODUCT: Dome + Low angle illumination system LTDMLAB2-WW

Illumination area $\varnothing = 60$ mm

Two independent illumination units in one single solution

Dome unit for homogeneous illuminations and low angle unit for dark field lightning can be independently operated.

Ultra-high power light output and strobe mode only operation

For the inspection of fast moving object and extended LED lifetime.

Rugged industrial design with built-in industrial connector

For easy integration into any machine vision system.

Compatible LTDV strobe controllers available

For easy and appropriate power, control and synchronization of the illuminator.

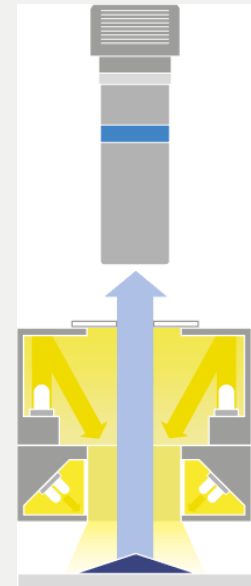

Applications – CASE 5

PRODUCT: Dome + Low angle illumination system LTDMLAB2-WW

Illumination area $\varnothing = 60 \text{ mm}$

APPLICATION: : Check for defects in rubber stopper for vial caps



OBJECT

IMAGE

dome

low angle

mix



Type of check:

- Cuts
- Scratches
- Fibers
- Contamination
- Spots



Fibers

Applications – CASE 6

Product: TCCAGE optics

90° lateral imaging:

the 4 orthonormal views allow visualization of object features that are hidden when looked at from the top

Long and thin object inspection:

the characteristic aspect ratio of the 4 image segments perfectly fits long and thin objects

Built-in illumination:

the device also incorporates two different light sources, for back and direct illumination

Suitable for measurement:

the telecentric optics makes this module perfect for any multiple-measurement application.

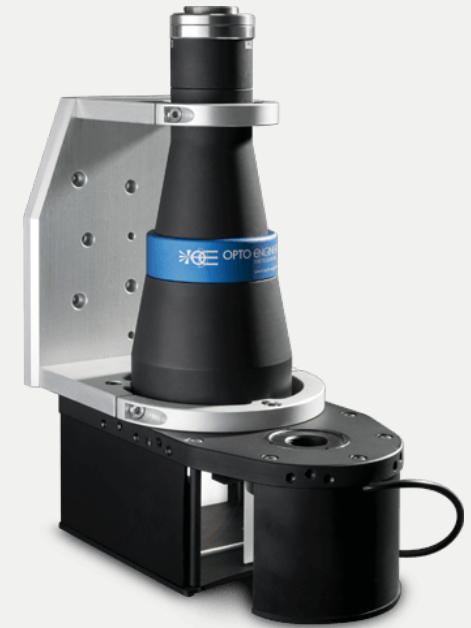

SCHEMATICS

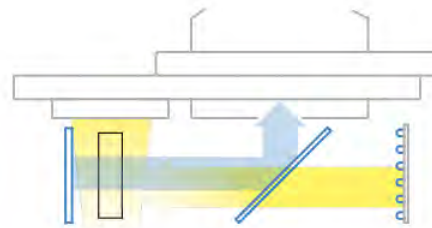
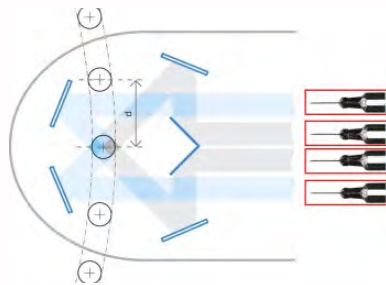

IMAGE



Applications – CASE 6

Product: TCCAGE optics

Application: syringes inspection

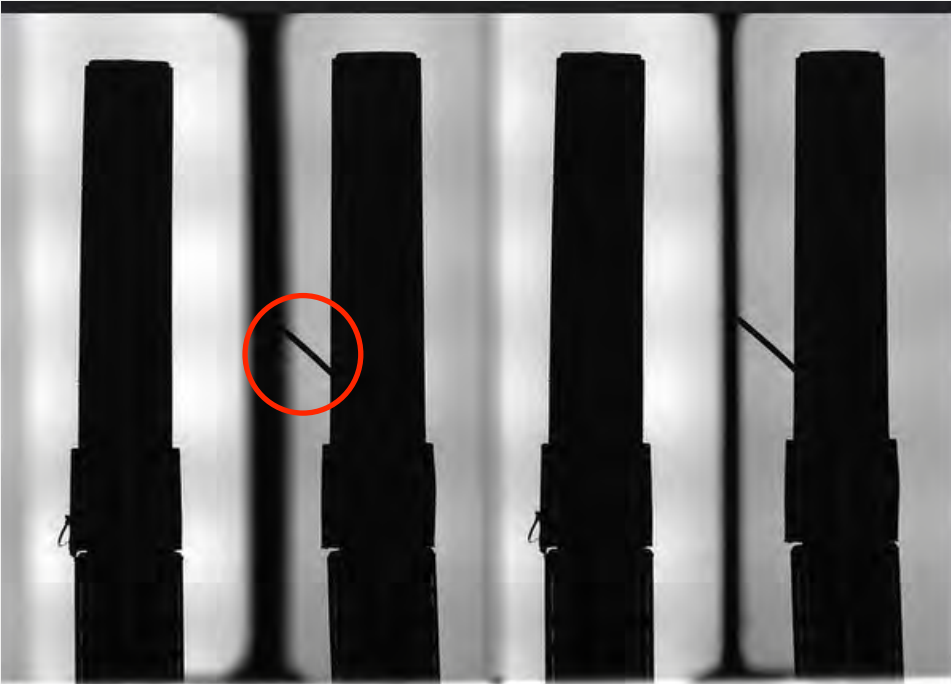

4 telecentric views allow inspection of all sides

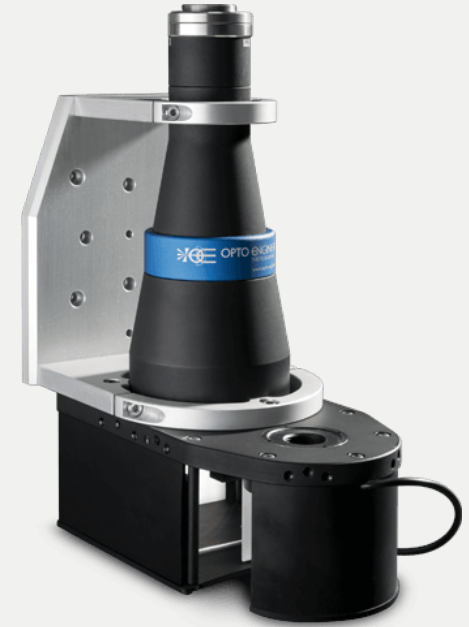

Type of check:

- Incorrect cap placement
- Bent needles

Applications – CASE 7

Product: PCPW012

Just one camera

No need for multiple cameras placed around and over the object

Wide viewing angle

45° object sides view makes otherwise hidden features visible

Complete surface inspection

Both inner and outer object surfaces can be imaged in one shot

Very high resolution

Even the tiniest defects can be detected.

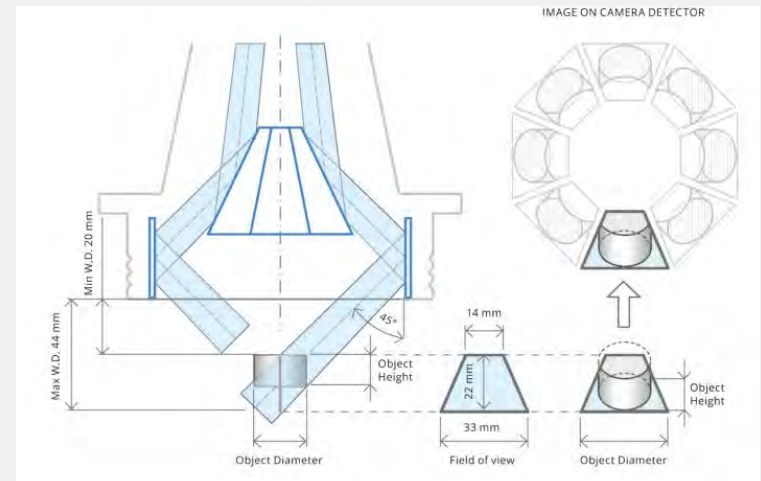

Applications – CASE 7

Product: PCPW012

Application: FLIP OFF cap inspection with one single camera

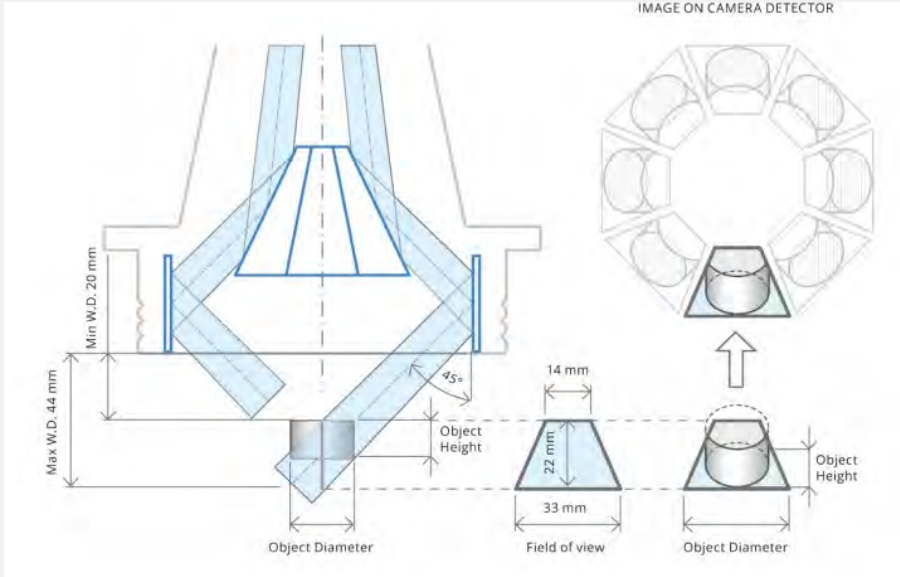

Applications – CASE 7

Product: PCPW012

Application: cap inspection with one single camera

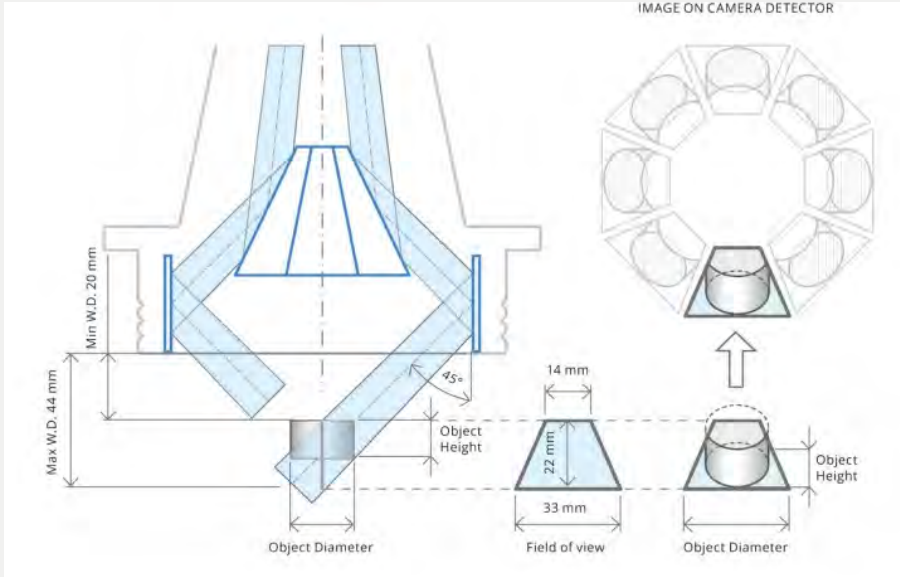

Applications – CASE 8

Product: Viewthrough system

Compact illumination solution designed to illuminate two sides of an object almost simultaneously



Applications – CASE 8

Compact illumination solution designed to illuminate two sides of an object

INSTANT 1

INSTANT 2

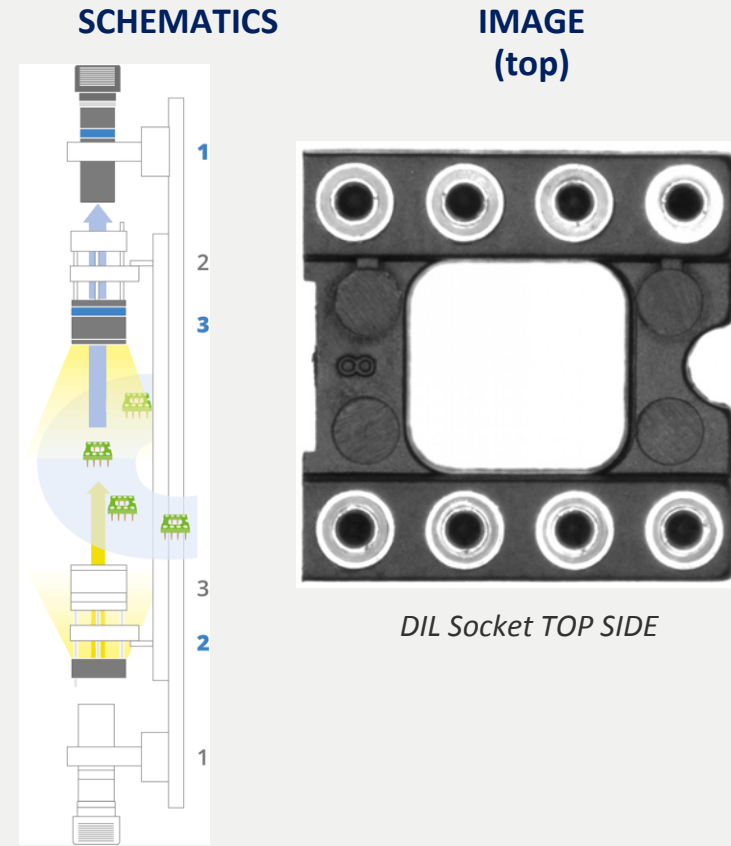
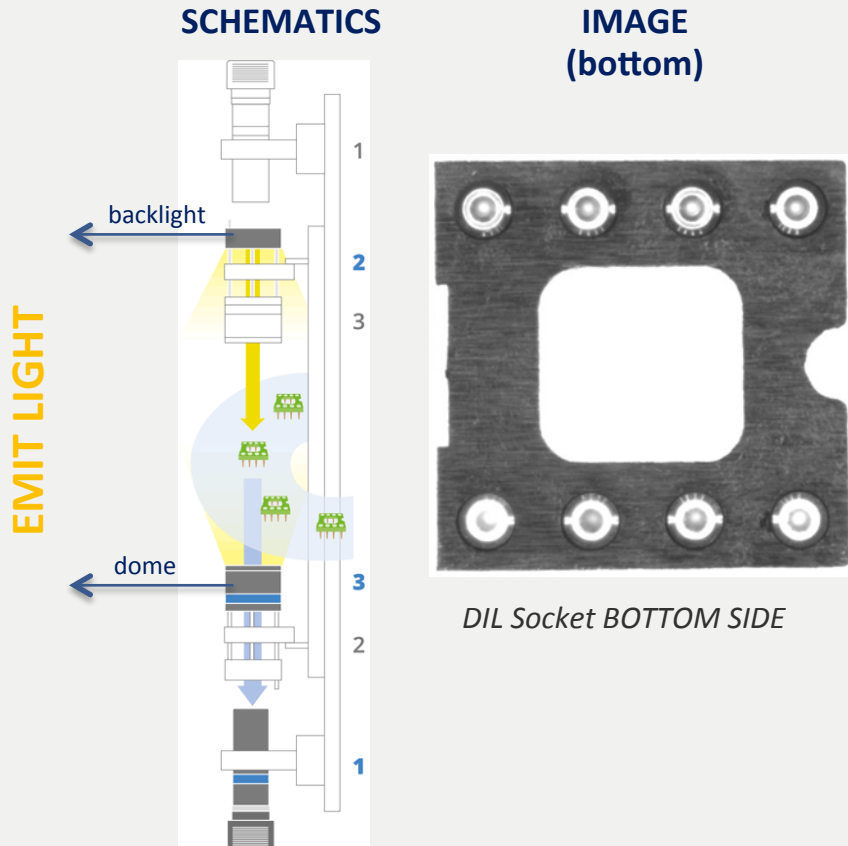

1 = Camera / 2 = Special active “view-through” backlight unit / 3 = Front Dome

Applications – CASE 8

Compact illumination solution designed to illuminate two sides of an object

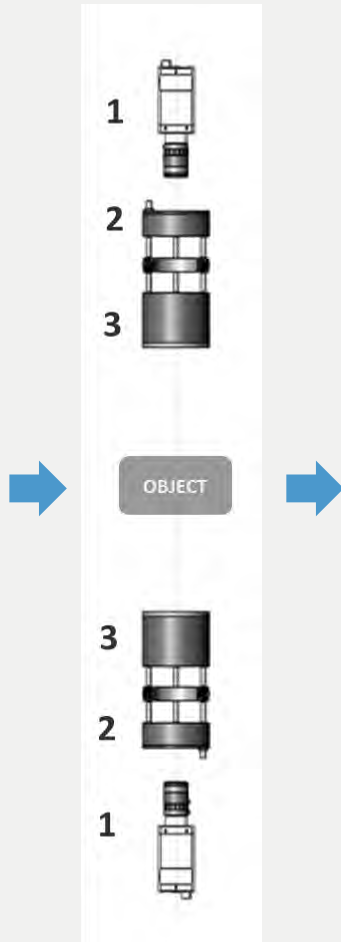
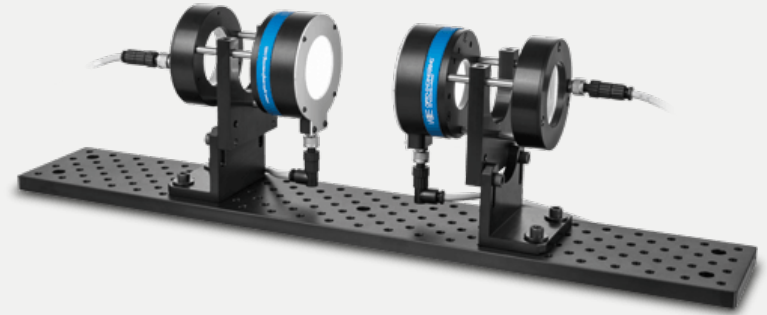

Achieved thanks to the special backlight units which act:

- as transparent windows (when turned off)
- as backlights (when turned on)

Compact space-saving solution for inspection of fast moving object

- Illuminates two sides of an object almost simultaneously

1 = Camera / 2 = Special active “view-through” backlight unit / 3 = Front Dome