

SEZIONE A-A

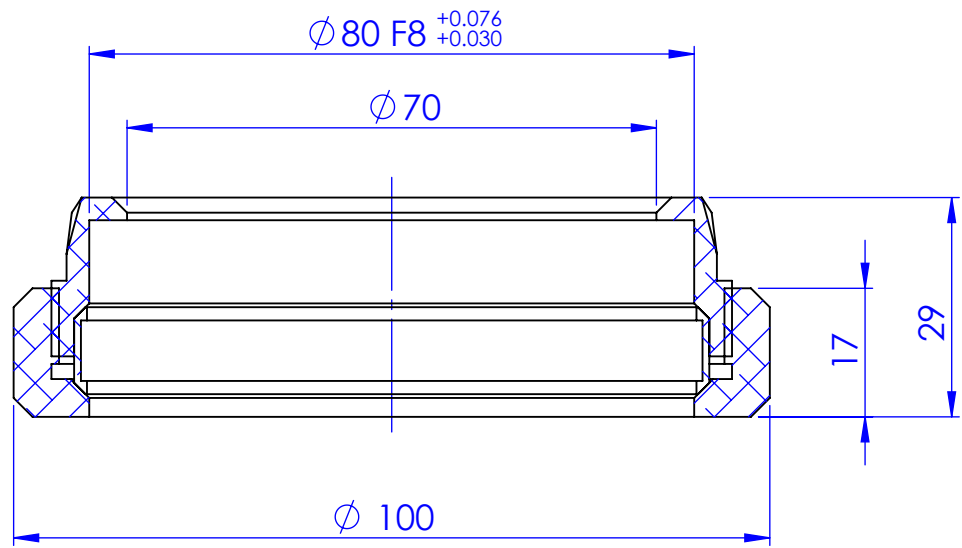

Material		N.A.				Mass	142 g	Scale	1:1																								
Surface treatment		N.A.				Part No. CO22422																											
Geometrical tolerance (ISO 2768-2)		Class		K		Description		CMWF056																									
Linear tolerance (ISO 2768-2)		Class		m		Undimensioned bevels		0.5x45°																									
<table border="1"> <tr> <td>0.5</td> <td>&gt;3÷</td> <td>&gt;6÷</td> <td>&gt;30÷</td> <td>&gt;120</td> <td>&gt;400÷</td> <td>&gt;1000</td> <td>&gt;2000</td> </tr> <tr> <td>±3</td> <td>6</td> <td>30</td> <td>120</td> <td>±400</td> <td>1000</td> <td>±2000</td> <td>±4000</td> </tr> <tr> <td>±0.1</td> <td>±0.1</td> <td>±0.2</td> <td>±0.3</td> <td>±0.5</td> <td>±0.8</td> <td>±1.2</td> <td>±2</td> </tr> </table>		0.5	>3÷	>6÷	>30÷	>120	>400÷	>1000	>2000	±3	6	30	120	±400	1000	±2000	±4000	±0.1	±0.1	±0.2	±0.3	±0.5	±0.8	±1.2	±2	Undimensioned radii		R 0.5		Drawing No. DP 22422-A			
0.5	>3÷	>6÷	>30÷	>120	>400÷	>1000	>2000																										
±3	6	30	120	±400	1000	±2000	±4000																										
±0.1	±0.1	±0.2	±0.3	±0.5	±0.8	±1.2	±2																										
		Date		Name		Sheet		1/1																									
		Designed		27/03/2014		Santini		1/1																									
		Drawn		09/04/2014		LSantini		1/1																									
Checked		30/11/2021		Rodella		<i>Secret and confidential - All rights reserved - No copy, dissemination or circulation is allowed unless specifically authorized in writing by OPTO ENGINEERING S.r.l. - Any violation shall be legally prosecuted.</i>																											
OPTO ENGINEERING S.r.l. - Mantova, Italy - Tel. +39 0376699111 - www.opto-e.com																																	

all dimensions are in mm