

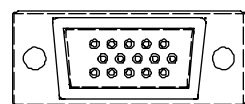

2-PHASE MOTOR PINOUT

- PIN 3 = +5Vdc
- PIN13 = COMMON
- PIN 8 = FAR LIMIT
- PIN 12 = NEAR LIMIT
- PIN 1 = MOTOR A+
- PIN 7 = MOTOR A-
- PIN 6 = MOTOR B+
- PIN 11 = MOTOR B-



15 PIN HIGH DENSITY
MALE D-SUB

OUTLINE

UNLESS OTHERWISE SPECIFIED DIMENSIONS ARE IN INCHES AND INCLUDE CHEMICALLY APPLIED OR PLATED FINISHES		THE CONTENTS OF THIS DOCUMENT ARE PROPRIETARY TO NAVITAR, ITS USE IS AUTHORIZED ONLY FOR RESPONDING TO REQUEST FOR QUOTATION OR PERFORMANCE OF WORK FOR NAVITAR		 ROCHESTER, NEW YORK			
SCALE:	1:1	0.0 inch 1.0					
WEIGHT:	1.6lbm	0.0 mm 25.0		MTR (STEP) 12X w/LS (HE) & CP			
DR:	R. PODLENA	DO NOT SCALE DRAWING					
CH:	P. BONAFEDE			SIZE	1-51318		
PROJECT #:				B			
DATE DR:	9/16/2003				SHEET 2 OF 2	REV	B