



See the possibilities

User Manual

SW-8000M-PMCL

Monochrome Line Scan Camera

Document Version:
1.5 Jul.2024

Thank you for purchasing this product.



Be sure to read this manual before use.

This manual includes important safety precautions and instructions on how to operate the unit. Be sure to read this manual to ensure proper operation.

Contents

Notice/Warranty/Certifications	3	EEN (Exposure Enable) Function	30
Usage Precautions	5	Test Pattern Function	31
Features	6	Binning	32
Parts Identifications	7	RS-232C Command Control	32
		Field Upgrade Function	32
		Noise reduction digital filter function	32
Preparation	10		
Preparation Flow	10		
Step 1:Installing the Software	10	Setting List	33
Step 2:Connecting Devices	12	Setting List	33
Step 3:Verifying Camera Operation	14		
Step 4:Configuring Basic Settings for the Camera	14	Miscellaneous	35
Control via External Triggers	15	Troubleshooting	35
Control without External Triggers	16	Specifications	36
Step 5:Adjusting the Image Quality	16	Spectral Response	38
Step 6:Configuring Various Other Settings	17	Dimensions	39
Step 7:Saving the Settings	17		
Basic Function Matrix	19	Index	42
Main Functions	20		
GPIO(Digital Input/Output Settings)	20		
Camera Output Formats	20		
Exposure Mode	20		
Image Output Timing	21		
Pixel Sensitivity Correction	27		
Gain Control	28		
LUT (Lookup Table) / Gamma Function	28		
ShadingCorrection	29		
Black Level Correction	29		
Variable Line Rate	29		
Electronic Shutter	30		

Notice

The material contained in this manual consists of information that is proprietary to JAI Ltd., Japan and may only be used by the purchasers of the product. JAI Ltd., Japan makes no warranty for the use of its product and assumes no responsibility for any errors which may appear or for damages resulting from the use of the information contained herein. JAI Ltd., Japan reserves the right to make changes without notice.

Company and product names mentioned in this manual are trademarks or registered trademarks of their respective owners.

Warranty

For information about the warranty, please contact your factory representative.

Certifications

CE compliance

As defined by the Directive 2004/108/EC of the European Parliament and of the Council, EMC (Electromagnetic compatibility), JAI Ltd., Japan declares that SW-8000M-PMCL complies with the following provisions applying to its standards.

EN 61000-6-3 (Generic emission standard part 1)

EN 61000-6-2 (Generic immunity standard part 1)

FCC

This equipment has been tested and found to comply with the limits for a Class B digital device, pursuant to Part 15 of the FCC Rules. These limits are designed to provide reasonable protection against harmful interference in a residential installation. This equipment generates, uses and can radiate radio frequency energy and, if not installed and used in accordance with the instructions, may cause harmful interference to radio communications. However, there is no guarantee that interference will not occur in a particular installation. If this equipment does cause harmful interference to radio or television reception, which can be determined by turning the equipment off and on, the user is encouraged to try to correct the interference by one or more of the following measures:

- Reorient or relocate the receiving antenna.
- Increase the separation between the equipment and receiver.
- Connect the equipment into an outlet on a circuit different from that to which the receiver is connected.
- Consult the dealer or an experienced radio/TV technician for help.

Warning

Changes or modifications to this unit not expressly approved by the party responsible for FCC compliance could void the user's authority to operate the equipment.

KC



제조년월은 제품상자의 라벨을 참조하십시오

China RoHS

The following statement is related to the regulation on “Measures for the Administration of the Control of Pollution by Electronic Information Products”, known as “China RoHS”. The table shows contained Hazardous Substances in this camera.

 mark shows that the environment-friendly use period of contained Hazardous Substances is 15 years.

重要注意事项

有毒有害物质或元素名称及含量表

根据中华人民共和国信息产业部『电器电子产品有害物质限制使用管理办法』，本产品《有毒有害物质或元素名称及含量表》如下。

部件名称	有毒有害物质或元素					
	铅 (Pb)	汞 (Hg)	镉 (Cd)	六价铬 (Cr (VI))	多溴联苯 (PBB)	多溴二苯醚 (PBDE)
SW-8000M-PMCL	x	○	○	○	○	○

○:表示该有毒有害物质在该部件所有均质材料中的含量均在 GB/T 26572-2011规定的限量要求以下。
x:表示该有毒有害物质至少在该部件的某一均质材料中的含量超出 GB/T 26572-2011规定的限量要求。

环保使用期限



电子信息产品中含有的有毒有害物质或元素在正常使用的条件下不会发生外泄或突变、电子信息产品用户使用该电子信息产品不会对环境造成严重污染 或对其人身、财产造成严重损害的期限。

数字「15」为期限15年。

Usage Precautions

Notes on cable configurations

The presence of lighting equipment and television receivers nearby may result in video and audio noise. In such cases, change the cable configurations or placement.

Notes on Camera Link cable connections

Secure the locking screws on the connector manually, and do not use a driver. Do not secure the screws too tightly. Doing so may wear down the screw threads on the camera. (Tightening torque: 0.15 N·m or less)

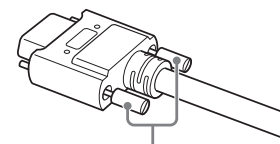

Secure manually.
Do not secure too tightly.

Notes on attaching the lens

Avoiding dust particles

When attaching the lens to the camera, stray dust and other particles may adhere to the sensor surface and rear surface of the lens. Be careful of the following when attaching the lens.

- Work in a clean environment.
- Do not remove the caps from the camera and lens until immediately before you attach the lens.
- To prevent dust from adhering to surfaces, point the camera and lens downward and do not allow the lens surface to come into contact with your hands or other objects.
- Always use a blower brush to remove any dust that adheres.
Never use your hands or cloth, blow with your mouth, or use other methods to remove dust.

Phenomena specific to CMOS image sensors

The following phenomena are known to occur on cameras equipped with CMOS image sensors. These do not indicate malfunctions.

- **Aliasing**
When shooting straight lines, stripes, and similar patterns, vertical aliasing (zigzag distortion) may appear on the monitor.
- **Blooming**
When strong light enters the camera, some pixels on the CMOS image sensor may receive much more light than they are designed to hold, causing the accumulated signal charge to overflow into surrounding pixels.
This “blooming” phenomenon can be seen in the image, but does not affect the operation of the camera.
- **Fixed pattern noise**
When shooting dark objects in high-temperature conditions, fixed pattern noise may occur throughout the entire video monitor screen.
- **Defective pixels**
Defective pixels (white and black pixels) of the CMOS image sensor are minimized at the factory according to shipping standards. However, as this phenomenon can be affected by the ambient temperature, camera settings (e.g., high sensitivity and long exposure), and other factors, be sure to operate within the camera's specified operating environment.

Notes on exportation

When exporting this product, please follow the export regulations of your country or region.

Features

The SW-8000M-PMCL is a line scan camera equipped with a 8192-pixel CMOS linear sensor. The camera has a Camera Link clock of 85 MHz and is capable of high-speed scanning at up to 99.9 kHz (Line Rate). 8-bit and 10-bit video output is possible via Camera Link. Camera and external trigger settings are configured via the Camera Link interface or the 12-pin connector.

Camera Link compatible interface

- Video outputs can be used as trigger inputs.

Output formats

You can choose from 8-bit, and 10-bit output.

Variety of pre-process functions

- **LUT (Lookup Table)**
Programmable control over gamma and contrast is possible.
- **Gamma correction**
Gamma can be set to 1.0, 0.9, 0.8, 0.75, 0.65, 0.6, 0.55, 0.5, or 0.45.
- **Shading correction (flat field)**
Non-uniformity (i.e., shading) in the amount of light generated by the lens and lighting equipment can be corrected.
- **Variable line rate**
By varying the line rate, the scanning speed of the camera can be matched to the feeding speed of the object, and the accumulation time can be lengthened to increase sensitivity.

Connection example:

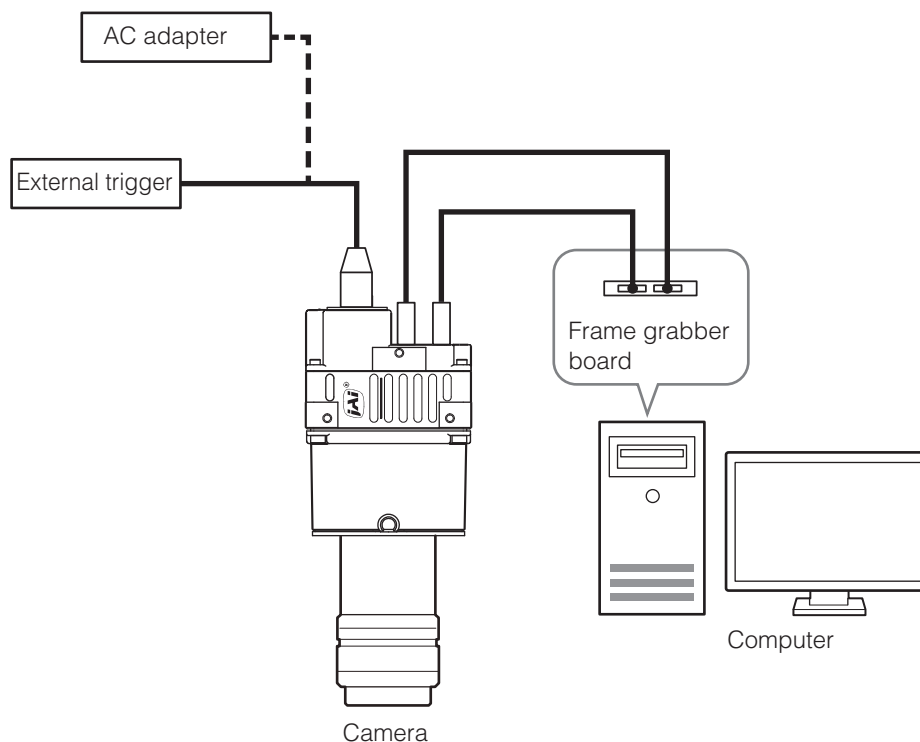

Parts Identification

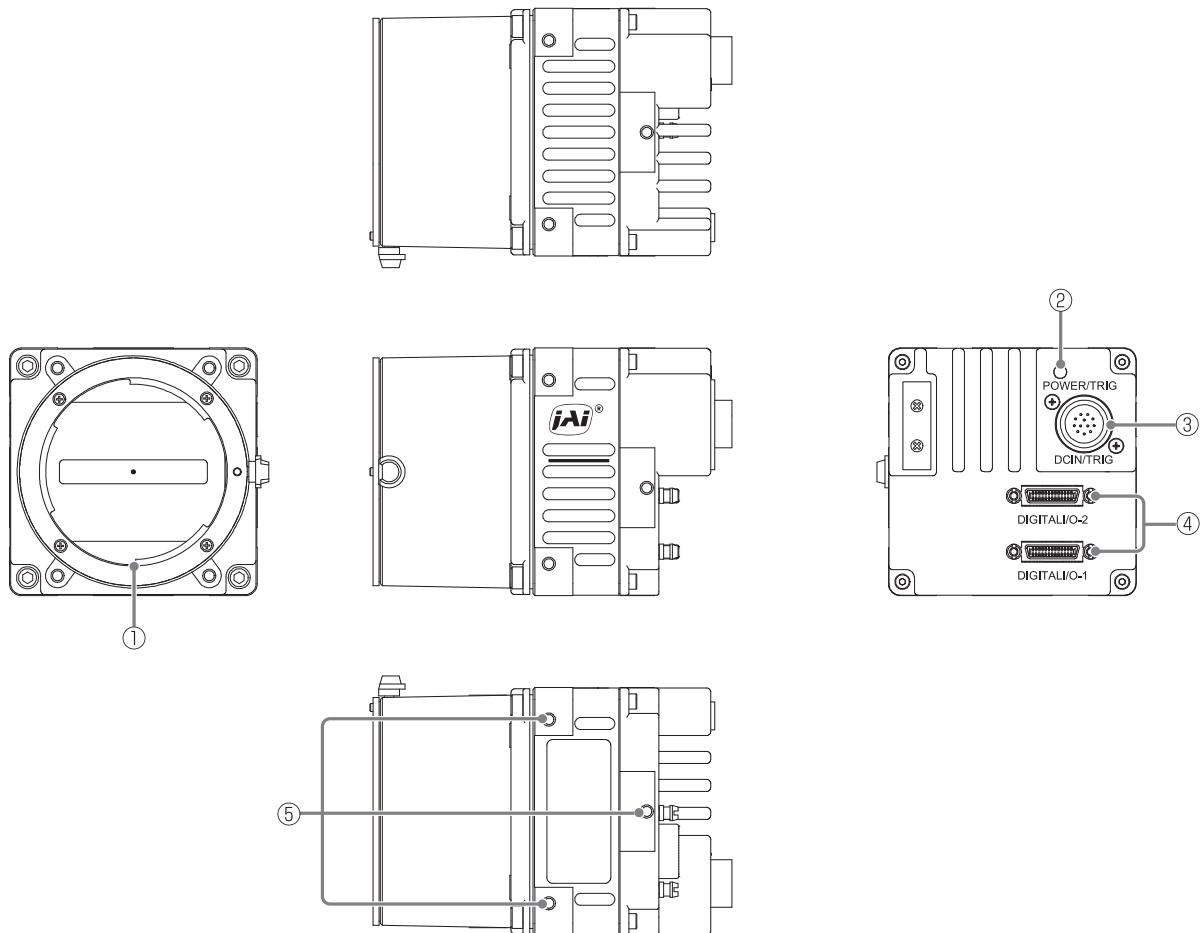

① Lens mount (M42 mount or F mount)

Mount an M42-mount lens or F-mount lens here.

- ❖ Before mounting a lens, be sure to refer to “Step 2: Connecting Devices” (page 12) and confirm the precautions for attaching a lens and the supported lens types.
- ❖ Lenses without the aperture ring on the lens side are not supported.

② POWER/TRIG LED

Indicates the power and trigger input status.

LED status and camera status

LED	Light	Status
POWER/TRIG LED	● Lit amber	Camera initializing.
	● Lit green	Operational and no triggers being input.
	✱ Blinking green	Operational and triggers being input. ❖ The blinking interval is not related to the actual input interval of the external trigger.

③ DC IN / trigger IN connector (12-pin round)

Connect the cable for a power supply (sold separately) or for DC IN /trigger IN here.

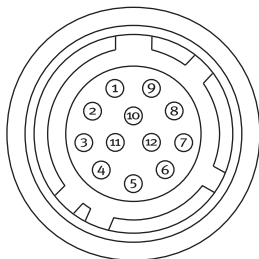

HR-10A-10R-12PB (71) (Hirose Electric or equivalent)

Pin No.	Input/ output	Signal	Description
1		GND	
2	Power In	DC IN	DC 12 V to 24 V \pm 10%
3		GND	
4		Reserved	External connection not possible
5		GND	
6	In	RxD In	RS-232C
7	Out	TxD Out	RS-232C
8		GND	
9	Out	TTL Out 1	Line1
10	In	TTL In 1	Line4
11	Power In	DC In	DC 12 V to 24 V \pm 10%
12		GND	

Caution

The DC IN / trigger IN connector or the CC1 of the DIGITAL I/O 1 video output connector will be used for external trigger inputs. You can switch which of these two are used via a command.

Compatible connectors

Camera side: HR10A-10R-12PB (71) (Hirose Electric or equivalent)

Cable side: HR-10A-10P-12S (plug) (Hirose Electric or equivalent)

④ DIGITAL I/O 1 and DIGITAL I/O 2 video output connectors

Connect a Cable Link compatible cable here.

Connector 1 (used during Base, Medium, Full, 8/10 bit output)

Pin No.	Input/ output	Signal	Description
1, 26		Power	Power
2 (-), 15 (+)	Out	TxOUT0	Data output
3 (-), 16 (+)	Out	TxOUT1	Data output
4 (-), 17 (+)	Out	TxOUT2	Data output
5 (-), 18 (+)	Out	TxCk	CL Clock
6 (-), 19 (+)	Out	TxOUT3	Data output
7 (+), 20 (-)	In	SerTC (RxD)	LVDS serial control
8 (-), 21 (+)	Out	SerTFG (TxD)	LVDS serial control
9 (-), 22 (+)	In	CC1	Trigger
10 (-), 23 (+)		CC2	Reserved
11, 24		N.C	
12, 25		N.C	
13, 14		Shield	GND

Connector 2 (used during Medium, Full, 8/10 bit output)

Pin No.	Input/ output	Signal	Description
1, 26		Power	Power
2 (-), 15 (+)	Out	TxOUT0	Data output
3 (-), 16 (+)	Out	TxOUT1	Data output
4 (-), 17 (+)	Out	TxOUT2	Data output
5 (-), 18 (+)	Out	TxCk	CL Clock
6 (-), 19 (+)	Out	TxOUT3	Data output
7 (+), 20 (-)		Reserved	
8 (-), 21 (+)	Out	TxOut0	Data output
9 (-), 22 (+)	Out	TxOut1	Data output
10 (-), 23 (+)	Out	TxOut2	Data output
11 (-), 24 (+)	Out	TxCLK	CL Clock
12 (-), 25 (+)	Out	TxOut3	Data output
13, 14		Shield	GND

Compatible connectors / cable assembly

Camera side: HDR-EC26FYTG2-SL+ (HONDA)

Cable: SDR connector cable for PoCL

- ❖ Compatible cable length is 0.5 to 10 m.
- ❖ The cable length at which communication will be possible will be limited when using a cable that is not compatible with Camera Link, a small diameter type cable or a high flex type cable.

⑤ **Camera locking screw holes (M3, 5 mm depth)**

Use this to connect the camera to the system.

Preparation

Preparation Flow

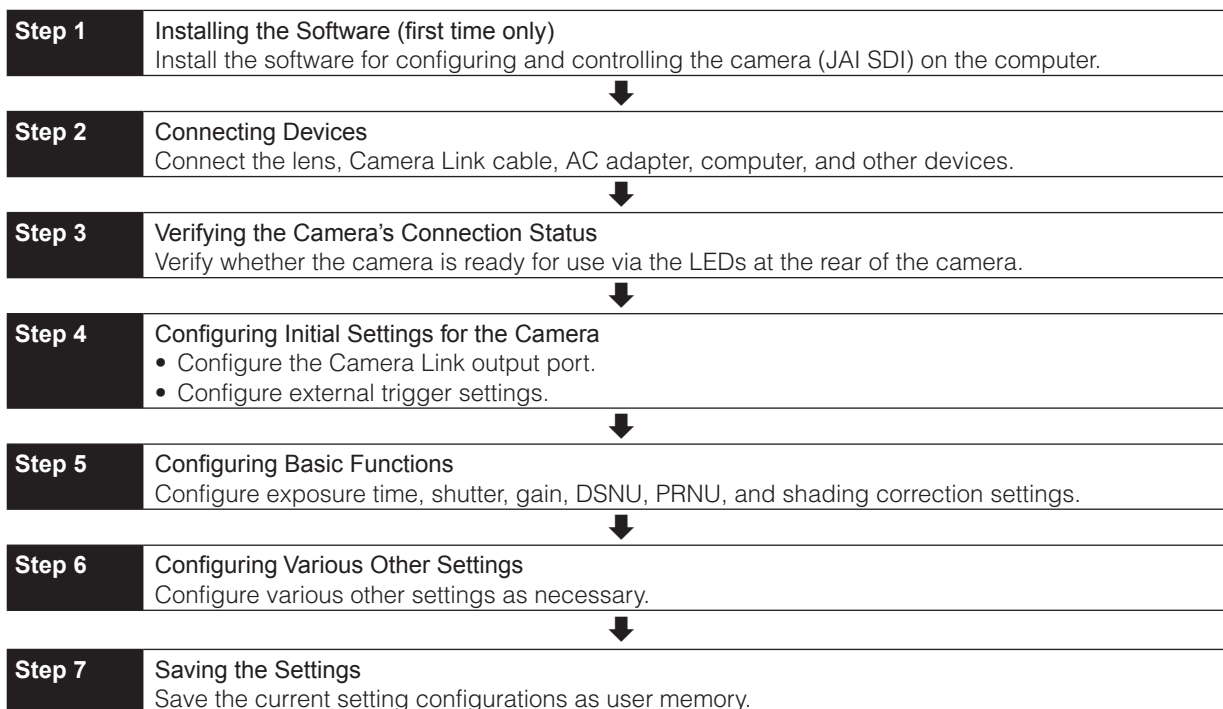

Step 1: Installing the Software (first time only)

When using the camera for the first time, install the software for configuring and controlling the camera (JAI SDK) on the computer.

❖ When you install JAI SDK, JAI Camera Control Tool will also be installed.

1 Download the “JAI - Getting Started Guide” and JAI SDK from the JAI website.
URL <http://www.jai.com/jp/camerasolutions/download/software>

2 Refer to the “JAI - Getting Started Guide,” and install JAI SDK on the computer.
The computer will restart when installation is complete.

Note

When the JAI SDK is installed, a camera driver for the interface is also part of the default installation. This Vision Filter Driver is added to every NIC/port on the host computer. As the driver is also added to the NIC/port for Internet connection, it may affect Internet access speed on some systems. If you think your Internet speed is affected, configure the following settings to disable the filter driver on that port.

① Open [Control Panel] → [Network and Internet] → [Connect to a network], and right-click the port used for Internet connection to open the properties dialog box.

- 2 Clear the [JAI GigE Vision Filter Driver] checkbox, and save.

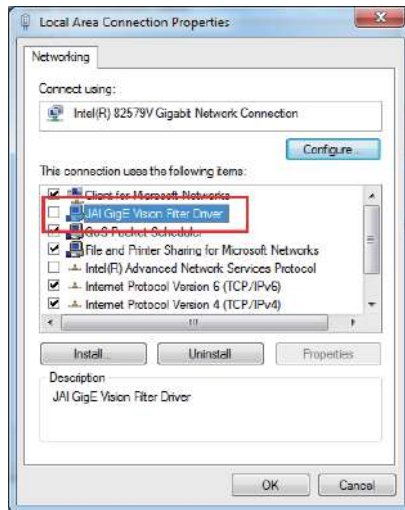

3 Verify the settings for using Camera Link.

The SW-8000M-PMCL supports GenIcam and Gen-CP. Check the following settings when controlling the camera via JAI SDK.

Checking the frame grabber board's settings

Settings must be configured on the frame grabber board to enable Gen-CP support.

For details, refer to the operating instructions for each board.

Checking JAI SDK's settings

- 1 Start JAI Control Tool, and click the  (Settings) icon at the top right.

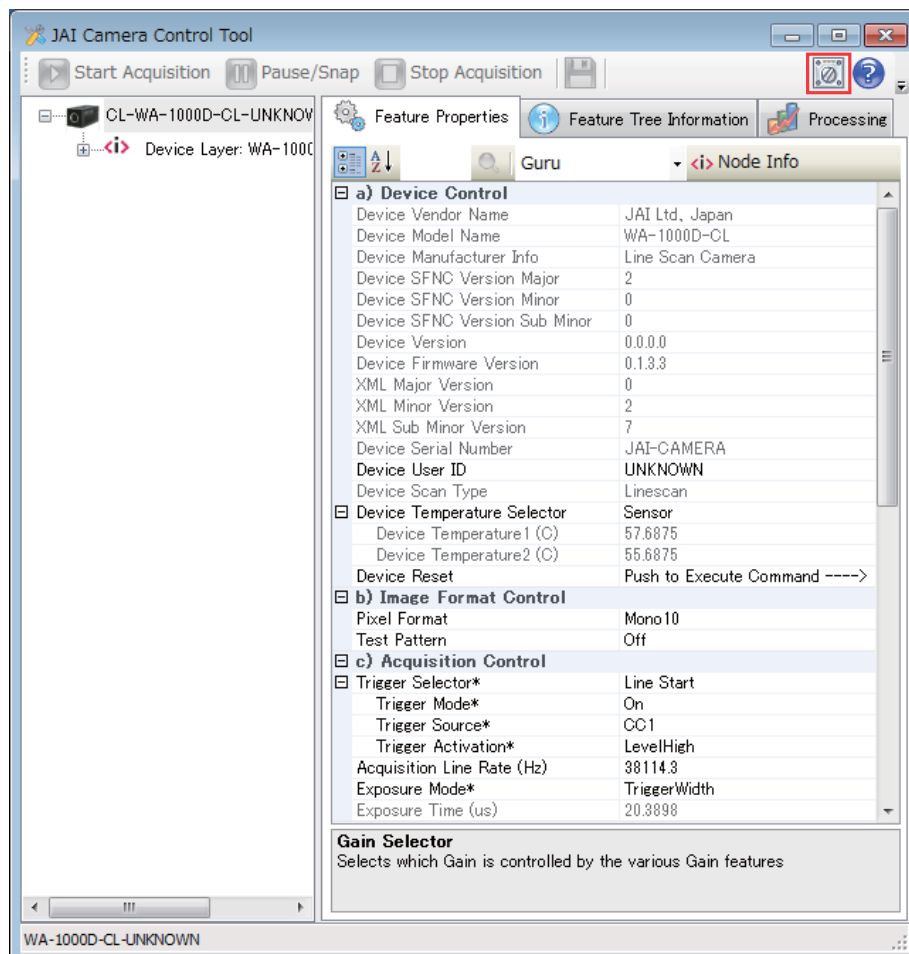

- 2 Check that the [JAI_GenCP_Camera_Link] and [Camera Link Transport Layer] settings are configured as follows.

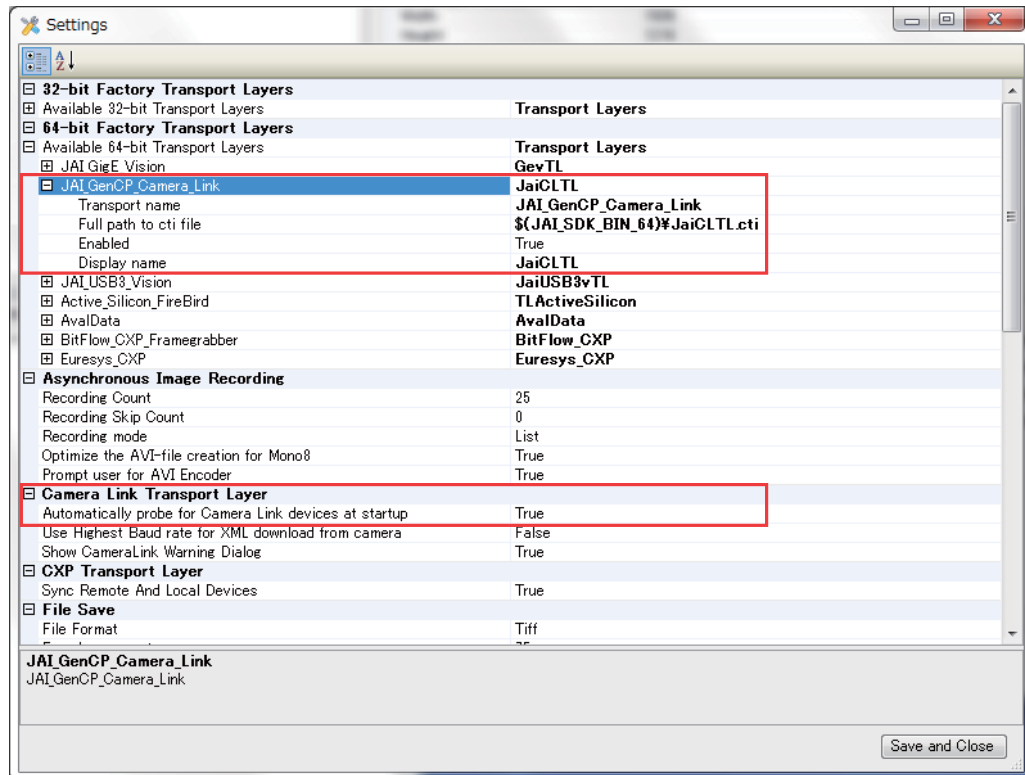

Step 2: Connecting Devices

Connect the lens, Camera Link cable, AC adapter, and other necessary devices. Attach the lens in a clean environment to prevent dust from adhering to the unit.

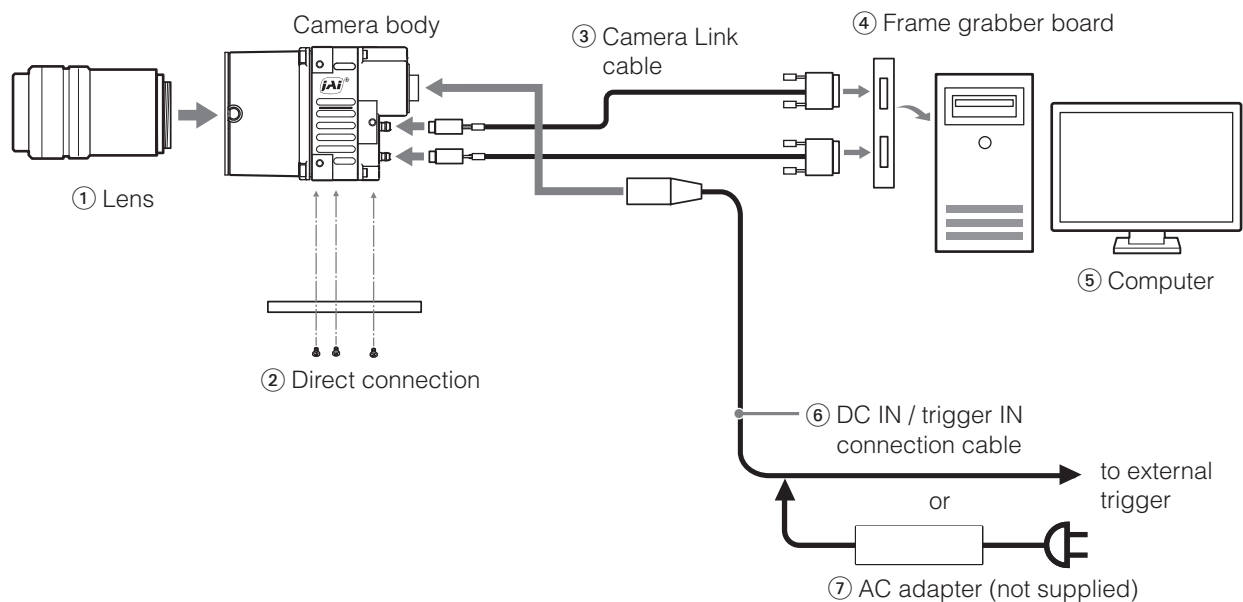

① Lens

Attach an M42-mount lens or F-mount lens.

Caution

The maximum performance of the camera may not be realized depending on the lens.

Note

The following formula can be used to estimate the focal length.

$$\text{focal length} = \text{WD}/(1 + \text{W}/\text{w})$$

WD: Working distance (distance between lens and object)

W: Width of object

w: Width of sensor 30.72 mm on this camera.

② Direct connection

When mounting the camera directly to another device, for example, use screws that match the camera locking screw holes on the camera. (M4, 6 mm depth)

Use the supplied screws to attach the tripod adapter plate.

Caution

For heavy lenses, be sure to support the lens itself. Do not use configurations in which its weight is supported by the camera.

③ Camera Link cable

Connect the Camera Link cables to the DIGITAL I/O 1 and DIGITAL I/O 2 video output connectors.

- Use Cable Link compatible cables.
- Refer to the specifications of the cable for details on its bend radius.
- ❖ For details on the cable, see “4 DIGITAL I/O 1 and DIGITAL I/O 2 video output connectors” (page 8).

Caution

Secure the locking screws on the connector manually, and do not use a driver. Do not secure the screws too tightly. Doing so may wear down the screw threads on the camera. (Tightening torque: 0.291 ± 0.049 N·m or less)

Caution

When supplying power from the camera link cable,
If only DIGITAL I / O 1 is connected, it may not operate correctly when the operating load is high.
Supply power from both DIGITAL I / O 1 and DIGITAL I / O 2.

④ Frame grabber board

Refer to the operating instructions of the frame grabber board, and configure settings on the computer as necessary.

⑤ Computer

Use a computer that meets the requirements of your frame grabber board.

⑥ DC IN / trigger IN connection cable

⑦ AC adapter (if necessary)

Connect the AC adapter and the round connector of the connection cable to the DC IN / trigger IN connector on the camera.

Step 3: Verifying the Camera Connection Status

When the necessary devices are connected and power is supplied to the camera, the POWER/TRIG LED at the rear of the camera lights amber, and initialization of the camera starts. When initialization is complete, the POWER/TRIG LED lights green.

Verify whether power is being supplied to the camera and whether the camera is operational by checking the rear LED.

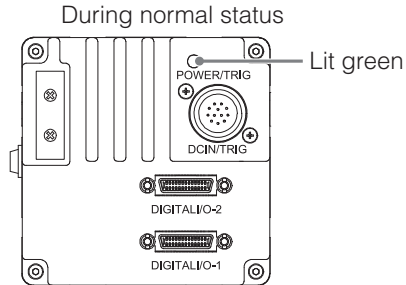

❖ For details on how to read the LED, see “LED status and camera status” (page 7) in the “Parts Identification” section.

Note

If the POWER/TRIG LED does not switch to green within minutes of supplying power, check the DC IN/TRIG cable, the Camera Link cable and other connections.

Step 4: Configuring Basic Settings for the Camera

Start Control Tool, connect the camera to the frame grabber board, and configure initial settings for the output format.

Connecting the Camera to the Control Tool

- 1** Start JAI Control Tool.
Cameras connected to the frame grabber board are detected, and a window appears. If they do not appear, right-click inside the window and select [Search for Cameras].
- 2** Select the camera you want to configure.
- 3** Check that the settings of the selected camera are displayed.

Configuring the Output Format

Configure the pixel format for images.

Item		Default value
Image Format Control	Pixel Format	mono8 (8-bit monochrome)

Control via External Triggers

When Controlling the Exposure Time Using Specified Exposure Times

Configure the settings as follows.

Item	Setting value / selectable range
Trigger Selector (trigger operation)	Line Start
Trigger Mode	On
Trigger Source (trigger signal source)	Any
Trigger Activation (trigger polarity)	Rising Edge (rising edge of input signal), Falling Edge (falling edge of input signal)
Exposure Mode	Timed (control via exposure time)
Exposure Time	Varies depending on the Tap Geometry and CL Pixel Clock settings.

- 1** Set [Exposure Mode] to [Timed].
([Timed] is the default setting.)
- 2** Specify the exposure time in [Exposure Time].
- 3** Set [Trigger Mode] to [On].
- 4** If necessary, change the [Trigger Source], and [Trigger Activation] settings.

When Controlling the Exposure Time Using the Pulse Width of the Trigger Input Signal

Configure the settings as follows.

Item	Setting value / selectable range
Trigger Selector (trigger operation)	Line Start
Trigger Mode	On
Trigger Source (trigger signal source)	Any
Trigger Activation (trigger polarity)	Level High (high-level duration), Level Low (low-level duration)
Exposure Mode	Trigger Width (control via trigger width)

- 1** Set [Trigger Mode] to [On] .
- 2** Set [Exposure Mode] to [Trigger Width] .
- 3** If necessary, change the [Trigger Source] and [Trigger Activation] settings.

Control Without External Triggers

When Controlling the Exposure Time Using Specified Exposure Times

Configure the settings as follows.

Item	Setting value / selectable range
Trigger Selector (trigger operation)	Line Start
Trigger Mode	Off
Exposure Mode	Timed (control via exposure time)
Exposure Time	Varies depending on the Tap Geometry and CL Pixel Clock settings.

- 1** Set [Exposure Mode] to [Timed].
([Timed] is the default setting.)
- 2** Set [Trigger Mode] to [On].
- 3** Specify a line period slower than the exposure time in [Acquisition Line rate].
- 4** Specify the exposure time in [Exposure Time].

When Not Controlling the Exposure Time

Configure the settings as follows.

Item	Setting value / selectable range
Exposure Mode	Off

The exposure will be performed with an exposure time equal to Line Period minus 3.8 μ s.

Step 5: Adjusting the Image Quality

To maximize the performance of the camera, configure its basic function in the following order.

* For details on this setting, "Variable Line Rate" (page 33) and "Electronic Shutter" (page 34). The exposure times and line rates that can be set will vary depending on the CL clock and Tap Geometry settings for Camera Link.

- 1** Configure the gain.
 - ❖ For details on this setting, see "Gain Control" (page 31).
- 2** Configure the exposure time.
- 3** Perform DSNU calibration.
 - ❖ The camera is equipped with a DSNU correction function. The function allows you to reduce DSNU generated by the sensor. To use the function, calibration must be performed within the camera and correction data must be created beforehand.

Procedure

- ❶ Close the lens aperture.
- ❷ Set [Pixel Black Correct] to [User].
- ❸ Execute [Pixel Black Direct], and perform calibration.

4 Perform PRNU calibration.

- ❖ The camera is equipped with a PRNU correction function. The function allows you to reduce PRNU generated by the sensor. To use the function, calibration must be performed within the camera and correction data must be created beforehand.

Procedure

- ❶ Make the signal output level as flat as possible within a range of 50% to 95%.
- ❷ Set [Pixel Gain Correct] to [User].
- ❸ Execute [Pixel Gain Direct], and perform calibration.

5 Adjust the black level.

- ❖ Open [Analog Control], and specify the black level in [Black Level] under [Black Level Selector].

Step 6: Configuring Various Other Settings

See “Settings List” (page 37), and configure settings as necessary.

* We recommend performing DSNU and PRNU calibration again whenever the line rate setting is changed significantly.

Step 7: Saving the Settings

The setting values configured in Control Tool will be deleted when the camera is turned off. By storing current setting values to user memory, you can load and recall them whenever necessary. You can save up to three sets of user memory settings (User 1 Data to User 3 Data).

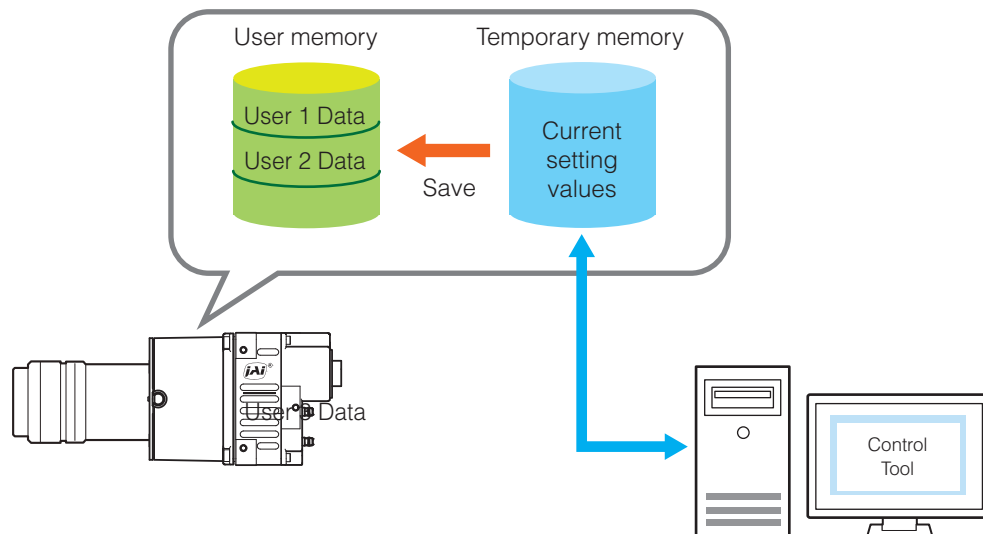
**Note**

The setting values are not saved to the computer (Control Tool).

■ To save user settings

- 1 Stop image capture.
- 2 Expand [User Set Control] and select the save destination ([User Set1] to [User Set3]) in [User Set Selector].

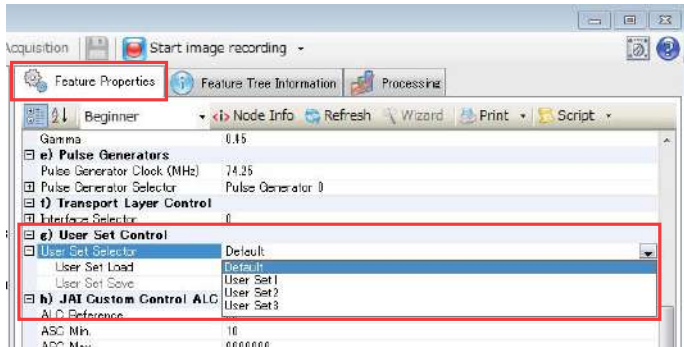

Note

The factory default setting values are stored in [Default] and cannot be overwritten.

Caution

Settings can only be saved when image capture on the camera is stopped.

- 3 Select [User Set Save], and click [Execute 'User Set Save' Command].

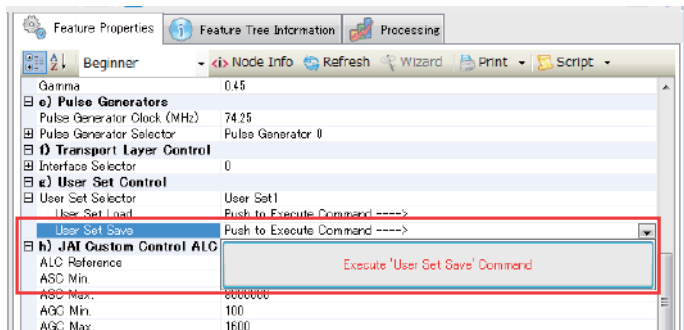

The current setting values are saved as user settings.

■ To load user settings

- 1 Stop image capture.
User settings can only be loaded when image capture on the camera is stopped.
- 2 Select the settings to load (Default, and User Set1 to User Set3) in [User Set Selector].
- 3 Select [User Set Load], and click [Execute 'User Set Load' Command].
The selected user settings are loaded.

❖ The next time the unit is started up, the settings selected in [User Set Selector] will be loaded automatically.

Basic Function Matrix

Valid Input/Output Combinations

The following signals can be used as sources for each output destination (Trigger Selector).

The combinations of source signals and output destinations are indicated in the following.

		Selector (Cross point switch output)	Output destination	
			Trigger Selector	Line Selector
Source signal (Cross point switch input)			Line Start	Line 2 Output Source
Signals to use as output	Line4 TTL In		○	○
	Line7 CC1		○	○
	LVAL		×	○
	Exposure Active (EEN)		×	○
	Low		×	○
	High		×	○

Main Functions

GPIO (Digital Input/Output Settings)

The unit can input/output the following signals to and from external input/output connectors.

External output	TTL Out (Line1)	DC IN / trigger IN connector (12-pin round)
External input	TTL IN (Line4)	DC IN / trigger IN connector (12-pin round)
	CC1 (Line7)	Camera Link cable

These signals can be used as triggers and other necessary signals within the camera or as signals output from the camera to the system, such as those used for lighting equipment control.

Signals are selected as follows.

- When using external signals or the signals of each GPIO module as trigger signals:
Select in [Trigger Selector] > [Trigger Source].
- When selecting the signals to use for external outputs:
Select in [Line Selector] > [Line Source].

Camera Output Formats

The SW-8000M-PMCL supports a variety of output formats.

The supported tap geometries are as follows.

The tap geometry settings on the camera side and the frame grabber board side must match. For details on frame grabber board settings, refer to the instruction manual of the board.

Tap geometry	CL configuration	
1X2	Base	bit: 8/10
1X3	Base	bit: 8
1X4	Medium	bit: 8/10
1X8	Full	bit: 8
1X8	80 bit (Deca)	bit: 10
1X10	80 bit (Deca)	bit: 8

*1 Effective pixels are restricted to 8184.

*2 Effective pixels are restricted to 8180.

■ Cable length reference

The Camera Link cable length is 10 m or less. The length of cable is 3 m or less when use CL Pixel Clock 84.82MHz, Tap Geometry 1x10. *3

*3 The length of cable you can use will also vary depending on type and maker.

Exposure Mode

The following operation modes are available on the camera.

Operation mode		Command	
Exposure Mode	Trigger Mode	EM	TG
OFF	OFF	0	0
	ON		1
Timed	OFF	1	0
	ON		1
PWC	ON	2	1

❖ For details on operation mode and function combinations, see “Basic Function Matrix” (page 19).

Image Output Timing

■ Trigger Control

The camera allows Line Start trigger controls to be performed via external trigger signals.

The Line Start trigger allows exposure control via the trigger signal inputs.

❖ The settings for exposure control and triggers are related to each other. Be sure to configure the settings described in “Connecting to the Camera to Control Tool” (page 14).

Shortest Repetition Period for Triggers

Trigger Mode ON, full resolution

		Shortest period (μs)
Exposure Mode OFF	Camera Link	Varies depending on the Tap Geometry and CL Clock settings.
	12-pin	
Exposure Mode Timed	Camera Link	
	12-pin	
PWC	Camera Link	
	12-pin	

Shortest Trigger Pulse Width

Trigger Mode ON

	Camera Link	12-pin
Exposure Mode OFF	3 μs	50 μs
Exposure Mode Timed	3 μs	50 μs
PWC	3 μs	50 μs

■ When [ExposureMode] is [Off]

• Line Start Trigger : Off

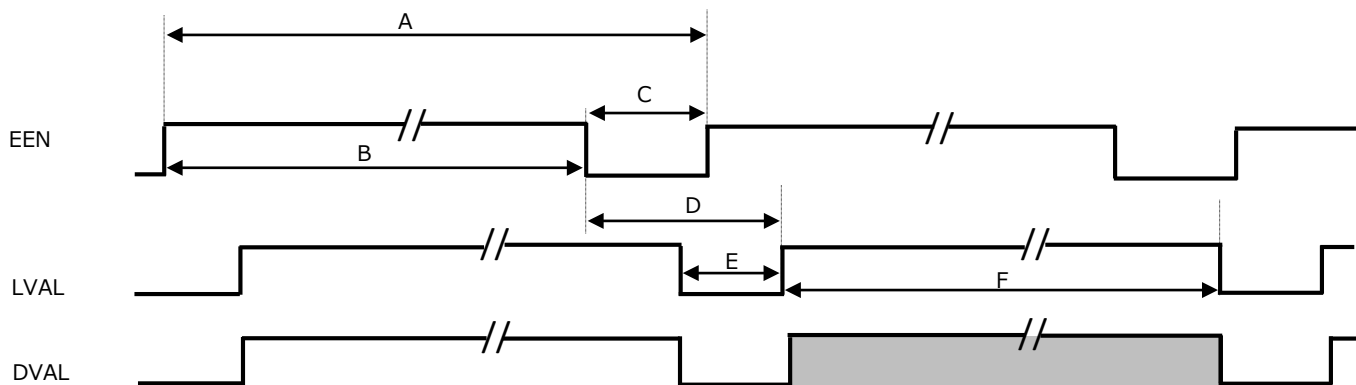

• Common to [Binning Off] and [Vertical Binning On]

TapGeometry	Bit/Pixel	CL Pixel Clock [MHz]	Line Period (CLK) [A]	Actual Exposure Time (μs) [B]	EEN invalid time (μs) [C]	Period from EEN Falling to LVAL rising (μs) [D]	Data invalid time (CLK) [E]	Data valid time (CLK) [F]
1X2	8/10	31.875	4115	61.32	3.8	18.9	19	4096
		42.5	4129	45.09	3.8	18.8	33	4096
		63.75	4115	28.87	3.8	18.8	19	4096
		85	4130	20.76	3.8	18.7	34	4096
1X3	8	31.875	2741	39.65	3.8	18.9	13	2728
		42.5	2750	28.85	3.8	18.9	22	2728
		63.75	2741	18.04	3.8	18.8	13	2728
		85	2751	12.62	3.8	18.7	23	2728
1X4	8/10	31.875	2058	28.86	3.8	18.9	10	2048
		42.5	2065	20.76	3.8	18.9	17	2048
		63.75	2058	12.65	3.8	18.8	10	2048
		85	2065	8.59	3.8	18.7	17	2048
1X8	8/10	31.875	1029	12.65	3.8	18.9	5	1024
		42.5	1033	8.59	3.8	18.9	9	1024
		63.75	1030	4.54	3.8	18.7	6	1024
		85	1033	2.51	3.8	18.7	9	1024
1X10	8	31.875	823	9.40	3.8	18.9	5	818
		42.5	826	6.14	3.8	18.9	8	818
		63.75	823	2.90	3.8	18.8	5	818
		85	849	1.41	3.8	18.7	31	818

*) About CL Pixel Clock [MHz] and time of 1 Clock.
 CL Pixel Clock [MHz] : 31.875 1CLK : 0.0315μs
 CL Pixel Clock [MHz] : 42.5 1CLK : 0.0236μs
 CL Pixel Clock [MHz] : 63.75 1CLK : 0.0158μs
 CL Pixel Clock [MHz] : 85 1CLK : 0.0118μs

■ When [ExposureMode] is [Off]

• Line Start Trigger : On

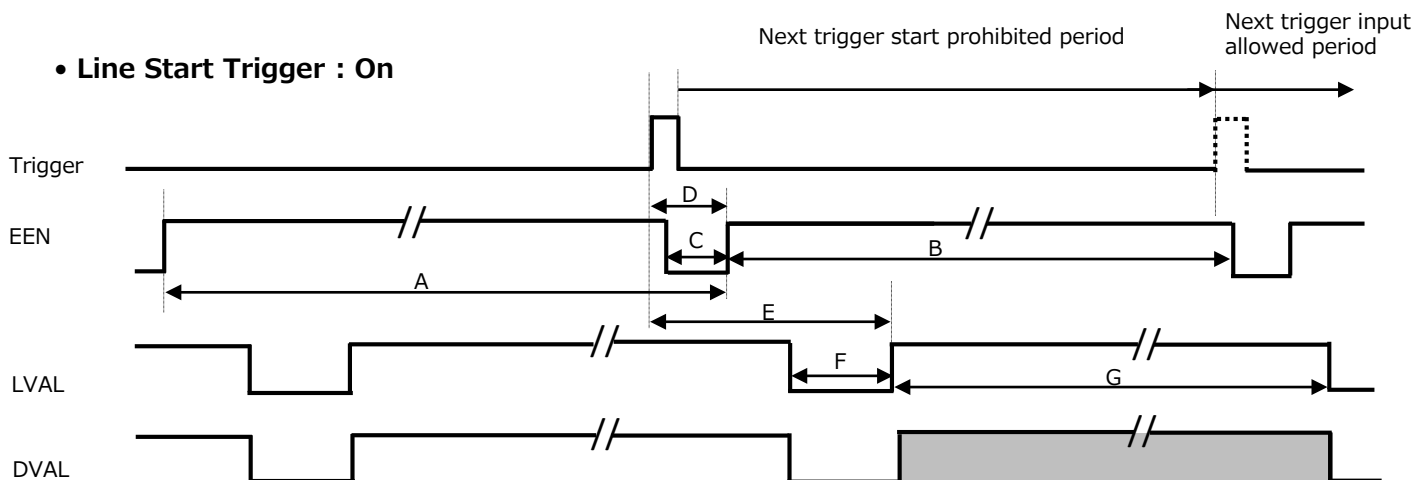

• Common to [Binning Off] and [Vertical Binning On]

TapGeometry	Bit/Pixel	CL Pixel Clock[MHz]	Line Period (CLK) [A]	Actual Exposure Time (μs) [B]	EEN invalid time (μs) [C]	Delay time from Trigger to EEN rising (μs) [D]	Period From EEN Falling to LVAL rising (μs) [E]	Data invalid time (CLK) [F]	Data valid time (CLK) [G]
1X2	8/10	31.875	4115	61.32	4.9	4.9	18.9	19	4096
		42.5	4129	45.09	4.9	4.9	18.8	33	4096
		63.75	4115	28.87	4.9	4.9	18.8	19	4096
		85	4130	20.76	4.9	4.8	18.7	34	4096
1X3	8	31.875	2741	39.65	4.9	4.9	18.9	13	2728
		42.5	2750	28.85	4.9	4.9	18.9	22	2728
		63.75	2741	18.04	4.9	4.9	18.8	13	2728
		85	2751	12.62	4.9	4.8	18.7	23	2728
1X4	8/10	31.875	2058	28.86	4.9	4.9	18.9	10	2048
		42.5	2065	20.76	4.9	4.9	18.9	17	2048
		63.75	2058	12.65	4.9	4.9	18.8	10	2048
		85	2065	8.59	4.9	4.8	18.7	17	2048
1X8	8/10	31.875	1029	12.65	4.9	4.9	18.9	5	1024
		42.5	1033	8.59	4.9	4.9	18.9	9	1024
		63.75	1030	4.54	4.9	4.9	18.7	6	1024
		85	1033	2.51	4.9	4.8	18.7	9	1024
1X10	8	31.875	823	9.40	4.9	4.9	18.9	5	818
		42.5	826	6.14	4.9	4.9	18.9	8	818
		63.75	823	2.90	4.9	4.9	18.8	5	818
		85	849	1.41	4.9	4.8	18.7	31	818

*) About CL Pixel Clock [MHz] and time of 1 Clock.
 CL Pixel Clock [MHz] : 31.875 1CLK : 0.0315μs
 CL Pixel Clock [MHz] : 42.5 1CLK : 0.0236μs
 CL Pixel Clock [MHz] : 63.75 1CLK : 0.0158μs
 CL Pixel Clock [MHz] : 85 1CLK : 0.0118μs

■ When [ExposureMode] is [Timed]

- Line Start Trigger : Off
Shutter select mode

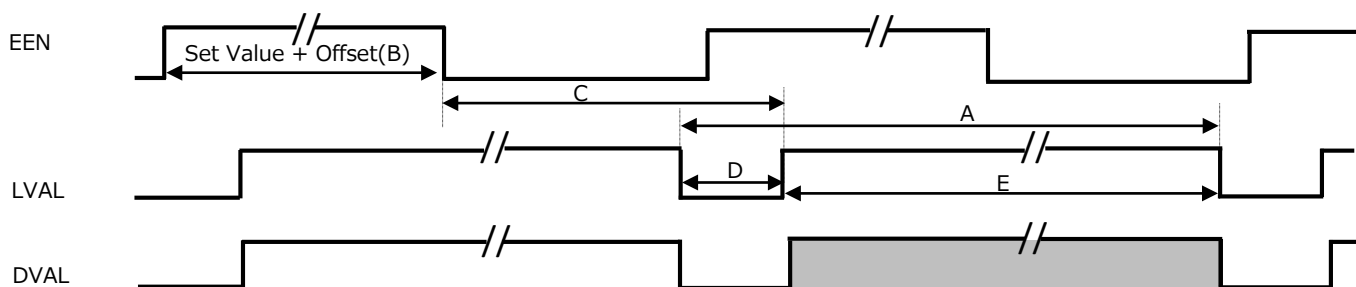

- Common to [Binning Off] and [Vertical Binning On]

TapGeometry	Bit/Pixel	CL Pixel Clock[MHz]	Line Period (CLK) [A]	Exposure Offset Time (μs) [B]	Period From EEN Falling to LVAL rising (μs) [C]	Data invalid time (CLK) [D]	Data valid time (CLK) [E]
1X2	8/10	31.875	4115	-1.2	18.9	19	4096
		42.5	4129	-1.2	18.8	33	4096
		63.75	4115	-1.2	18.8	19	4096
		85	4130	-1.2	18.7	34	4096
1X3	8	31.875	2741	-1.2	18.9	13	2728
		42.5	2750	-1.2	18.9	22	2728
		63.75	2741	-1.2	18.8	13	2728
		85	2751	-1.2	18.7	23	2728
1X4	8/10	31.875	2058	-1.2	18.9	10	2048
		42.5	2065	-1.2	18.9	17	2048
		63.75	2058	-1.2	18.8	10	2048
		85	2065	-1.2	18.7	17	2048
1X8	8/10	31.875	1029	-1.2	18.9	5	1024
		42.5	1033	-1.2	18.9	9	1024
		63.75	1030	-1.2	18.7	6	1024
		85	1033	-1.2	18.7	9	1024
1X10	8	31.875	823	-1.2	18.9	5	818
		42.5	826	-1.2	18.9	8	818
		63.75	823	-1.2	18.8	5	818
		85	849	-1.2	18.7	31	818

*) About CL Pixel Clock [MHz] and time of 1 Clock.
 CL Pixel Clock [MHz] : 31.875 1CLK : 0.0315μs
 CL Pixel Clock [MHz] : 42.5 1CLK : 0.0236μs
 CL Pixel Clock [MHz] : 63.75 1CLK : 0.0158μs
 CL Pixel Clock [MHz] : 85 1CLK : 0.0118μs

■ When [ExposureMode] is [Timed]

• Line Start Trigger : On Shutter select mode

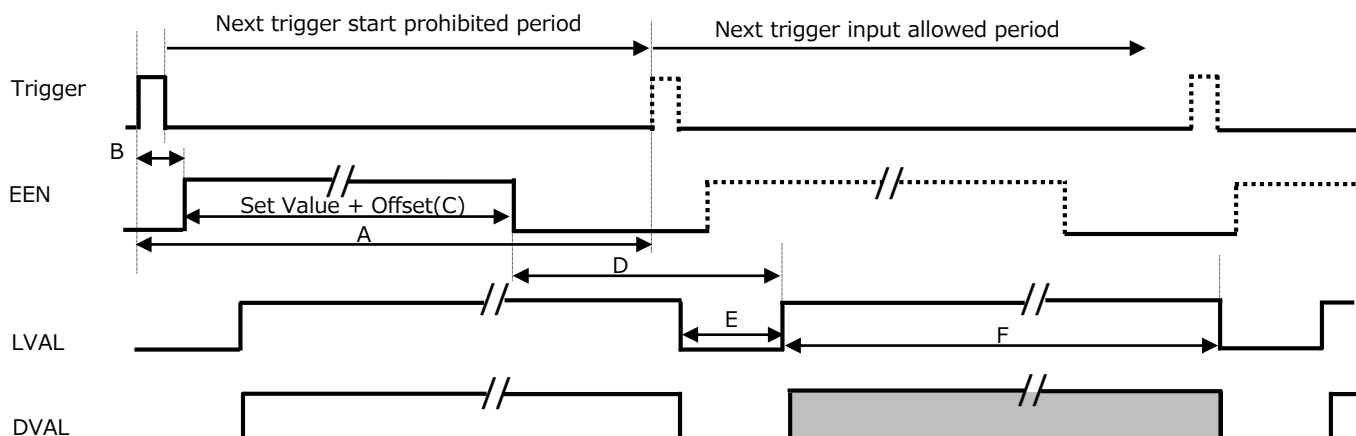

• Common to [Binning Off] and [Vertical Binning On]

TapGeometry	Bit/Pixel	CL Pixel Clock[MHz]	Line Period (CLK) [A]	Delay time From Trigger to EEN rising (μs) [B]	Exposure Offset Time (μs) [C]	Period From EEN Falling to LVAL rising (μs) [D]	Data invalid time (CLK) [E]	Data valid time (CLK) [F]
1X2	8/10	31.875	4115	1.1	-1.2	18.9	19	4096
		42.5	4129	1.1	-1.2	18.8	33	4096
		63.75	4115	1.1	-1.2	18.8	19	4096
		85	4130	1.1	-1.2	18.7	34	4096
1X3	8	31.875	2741	1.1	-1.2	18.9	13	2728
		42.5	2750	1.1	-1.2	18.9	22	2728
		63.75	2741	1.1	-1.2	18.8	13	2728
		85	2751	1.1	-1.2	18.7	23	2728
1X4	8/10	31.875	2058	1.1	-1.2	18.9	10	2048
		42.5	2065	1.1	-1.2	18.9	17	2048
		63.75	2058	1.1	-1.2	18.8	10	2048
		85	2065	1.1	-1.2	18.7	17	2048
1X8	8/10	31.875	1029	1.1	-1.2	18.9	5	1024
		42.5	1033	1.1	-1.2	18.9	9	1024
		63.75	1030	1.1	-1.2	18.7	6	1024
		85	1033	1.1	-1.2	18.7	9	1024
1X10	8	31.875	823	1.1	-1.2	18.9	5	818
		42.5	826	1.1	-1.2	18.9	8	818
		63.75	823	1.1	-1.2	18.8	5	818
		85	849	1.1	-1.2	18.7	31	818

*) About CL Pixel Clock [MHz] and time of 1 Clock.
 CL Pixel Clock [MHz] : 31.875 1CLK : 0.0315μs
 CL Pixel Clock [MHz] : 42.5 1CLK : 0.0236μs
 CL Pixel Clock [MHz] : 63.75 1CLK : 0.0158μs
 CL Pixel Clock [MHz] : 85 1CLK : 0.0118μs

■ When [ExposureMode] is [TriggerWidth]

• Line Start Trigger : On PWC mode

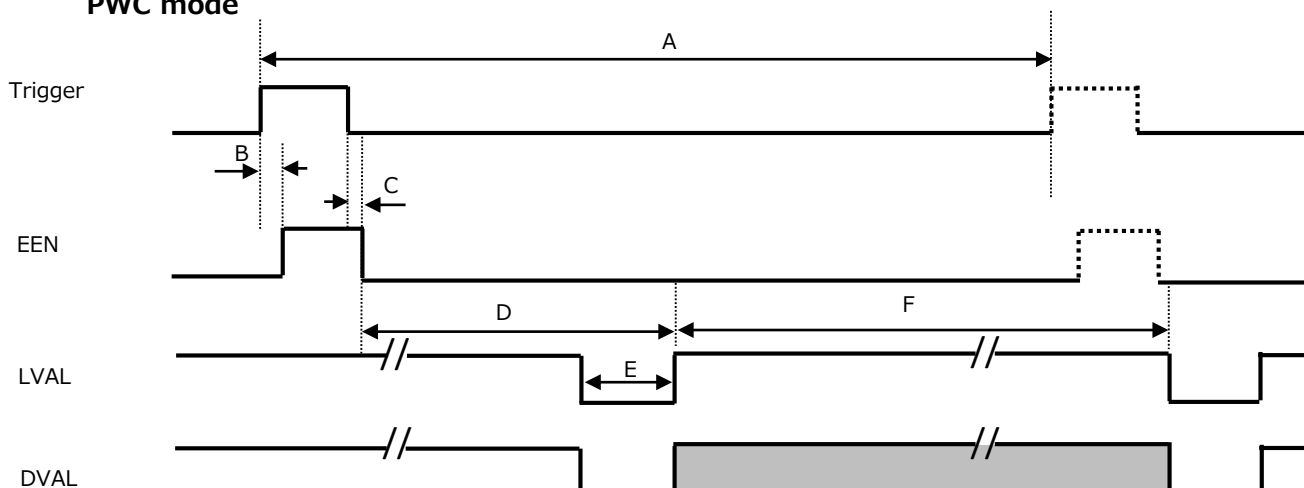

• Common to [Binning Off] and [Vertical Binning On]

TapGeometry	Bit/Pixel	CL Pixel Clock[MHz]	Line Period (CLK) [A]	Delay Time from Trigger rising to EEN rising (μs) [B]	Delay time From Trigger falling to EEN falling (μs) [C]	Period from EEN Falling to LVAL rising (μs) [D]	Data invalid time (CLK) [E]	Data valid time (CLK) [F]
1X2	8/10	31.875	4115	1.1	1.15	18.9	19	4096
		42.5	4129	1.1	1.15	18.8	33	4096
		63.75	4115	1.1	1.15	18.8	19	4096
		85	4130	1.1	1.15	18.7	34	4096
1X3	8	31.875	2741	1.1	1.15	18.9	13	2728
		42.5	2750	1.1	1.15	18.9	22	2728
		63.75	2741	1.1	1.15	18.8	13	2728
		85	2751	1.1	1.15	18.7	23	2728
1X4	8/10	31.875	2058	1.1	1.15	18.9	10	2048
		42.5	2065	1.1	1.15	18.9	17	2048
		63.75	2058	1.1	1.15	18.8	10	2048
		85	2065	1.1	1.15	18.7	17	2048
1X8	8/10	31.875	1029	1.1	1.15	18.9	5	1024
		42.5	1033	1.1	1.15	18.9	9	1024
		63.75	1030	1.1	1.15	18.7	6	1024
		85	1033	1.1	1.15	18.7	9	1024
1X10	8	31.875	823	1.1	1.15	18.9	5	818
		42.5	826	1.1	1.15	18.9	8	818
		63.75	823	1.1	1.15	18.8	5	818
		85	849	1.1	1.15	18.7	31	818

*) About CL Pixel Clock [MHz] and time of 1 Clock.
 CL Pixel Clock [MHz] : 31.875 1CLK : 0.0315μs
 CL Pixel Clock [MHz] : 42.5 1CLK : 0.0236μs
 CL Pixel Clock [MHz] : 63.75 1CLK : 0.0158μs
 CL Pixel Clock [MHz] : 85 1CLK : 0.0118μs

Pixel Sensitivity Correction

Correct variations between the sensor's pixels.

Calibration must be performed within the camera and correction data must be created beforehand. DSNU (PixelBlackCorrect) / PRNU (PixelGainCorrect) can be reduced using that correction data. We recommend performing calibration and creating correction data whenever the line rate setting or Analog base gain setting or vertical binning setting are changed significantly.

*Correction data is saved for DSNU (PixelBlackCorrect) / PRNU (PixelGainCorrect) according to the conditions adjusted at the factory.

*A single correction data entry can be saved on the camera for a each user.

When calibration is performed, the correction data is saved to the non-volatile ROM at the same time.

PRNU Correction (PixelGainCorrect)

PRNU (photo response non-uniformity) is a variation between pixels generated by the sensor under bright conditions. If the line rate is slowed or a long exposure time is set, the dark current in the sensor may change and the state of the PRNU may change.

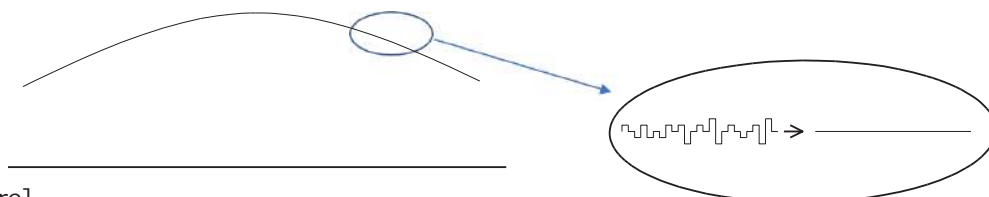

[Correction procedure]

1. Specify the user area to save the gain correction value with [PixelGainCorrect] of [JAICustomControl].
2. Gain correction data is automatically generated by [PixelGainDirect] of [JAICustomControl] and saved in the user area specified in 1.
3. You can check the execution result of gain correction by [PixelGainDetectStatus] of [JAICustomControl].

DSNU Correction (PixelBlackCorrect)

DSNU (dark signal non-uniformity) is a variation between pixels in the dark areas generated by the sensor. If the line rate is slowed or a long exposure time is set, the dark current in the sensor may change and the state of the DSNU may change.



[Correction procedure]

1. Specify the user area to save the black level correction value with [PixelBlackCorrect] of [JAICustomControl].
2. Black level correction data is automatically generated by [PixelBlackDirect] in [JAICustomControl] and saved in the user area specified in 1.
3. You can check the execution result of black level correction by [PixelBlackDetectStatus] of [JAICustomControl].

Gain Control

The following gain functions are available on the camera.

- Analog base gain
- Digital gain

■ Analog base gain

Analog base gain (ABG) is gain that is performed to the analog video signal output from the sensor. The gain steps can be configured to one of four levels.

AnalogBaseGain setting value	Scaling*
0	0 dB (×1)
1	6 dB (×2)
2	9.54 dB (×3)
3	12 dB (×4)

* Sensitivity (all scaling values are TYP values)

■ Digital gain

- Manual
0 to +36 dB (×1 to ×64), ×0.01/steps

The following two gain values are added for the total gain value.

Total Gain = AnalogBaseGain (dB) + DigitalGain (dB)

LUT (Lookup Table) / Gamma Function

The LUT function is used to generate a non-linear mapping between signal values captured on the sensor and those that are output from the camera.

The gamma function corrects the output signals from the camera beforehand (reverse correction), taking into consideration the light-emitting properties of the monitor display.

The Gamma, LUT, and OFF settings can be selected on this camera. When OFF is selected, γ 1 (linear) sensitivity is applied.

The factory default setting is OFF.

■ Gamma

When [Gamma] is set, you can switch the curve characteristics by 9 steps.

1.0, 0.9, 0.8, 0.75, 0.65, 0.6, 0.55, 0.5, 0.45

■ LUT

In this mode, the sensitivity curve can be configured.

Setting range: 0 to 4096LSB (100%)

Number of setting points: 256

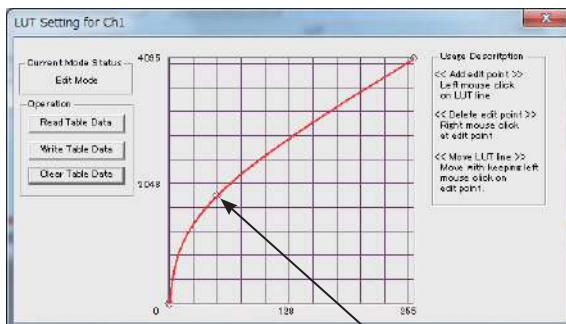

Setting point

Shading Correction

The shading correction is a function that corrects non-uniformity (i.e., shading) in the amount of light generated by the lens and lighting equipment.

The following shading correction modes are available on the camera.

■ Flat shading correction

The range of brightness that can be corrected is within $\pm 30\%$ of the region with the highest signal level on one line.

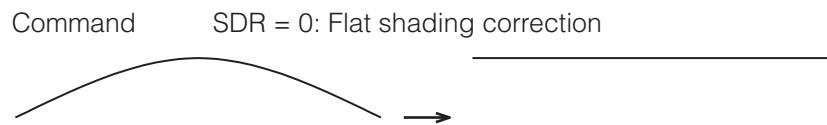

- ❖ Complete correction may not be possible depending on the optical system and light source you are using.
- ❖ Data based on corrections performed under factory conditions is stored for this function.

■ To perform the shading function

The function is turned ON/OFF via serial communication.

This function is not dependent on the operation mode, but is effective when used during actual use.

- ❖ You can also save the setting and have it applied whenever the power is subsequently turned on. For details on saving the setting, see “Step 7: Saving the Settings” (page 17).

Black Level Correction

Black level correction is a function for adjusting the setup level.

When this function is used, the following is performed for the gain mode setting.

-133 to +255 LSB@12-bit

Variable Line Rate

You can set the line rate to 1L or more.

This function can be used to match the scanning speed of the camera to the feeding speed of the object or to lengthen the accumulation time to increase sensitivity.

- Variable range: 66 Hz to 99.9 kHz (10 μ s to 15.15 ms)
- Variable unit: 10 ns (1clk)
- Supported operation modes: Exposure Mode OFF / internal trigger
Exposure Mode Timed / internal trigger

- ❖ You can also save the setting and have it applied whenever the power is subsequently turned on, but this requires additional operations.
- ❖ Switching and settings storage for this function is performed via serial communication.
- ❖ The black level will change depending on the line rate, so be sure to readjust the black level after changing the line rate or trigger period.

■ Auto line rate configuration function

You can automatically configure the optimal line rate when you want to prioritize sensitivity.

- Supported operation modes: When Trigger Mode OFF, Exposure Mode OFF
- ❖ You can also save the setting and have it applied whenever the power is subsequently turned on. For details on saving the setting, see “Step 7: Saving the Settings” (page 17) .

Electronic Shutter

When you use this function, you can set the exposure to a preconfigured accumulation time, regardless of the line rate.

- Variable range: 1.8 μ s to 15.148 ms
- Variable unit: 1.0 μ s (1clk)
- Supported operation modes: When Trigger Mode ON, Exposure Mode Timed
- ❖ Actual exposure time is the value set in [Exposure Time] minus 1.2 μ s

Caution

In “Trigger Mode OFF, Exposure Mode Timed” mode, the line rate configured will be the maximum value at which the shutter operates. However, in “Trigger Mode ON, Exposure Mode Timed” mode, the input trigger period will be the maximum value.

- ❖ You can also save the setting and have it applied whenever the power is subsequently turned on, but this requires addition operations.
- ❖ Switching and settings changing and storage for this function is performed via serial communication.

EEN (Exposure Enable) Function

Perform external output for the timing at which video is accumulated to the sensor.
The signal is output to the DC IN / trigger IN connector (12-pin round) and the DIGITAL I/O 1 video output connector (Camera Link).

Example: Output to the DIGITAL I/O 1 video output connector (Camera Link)

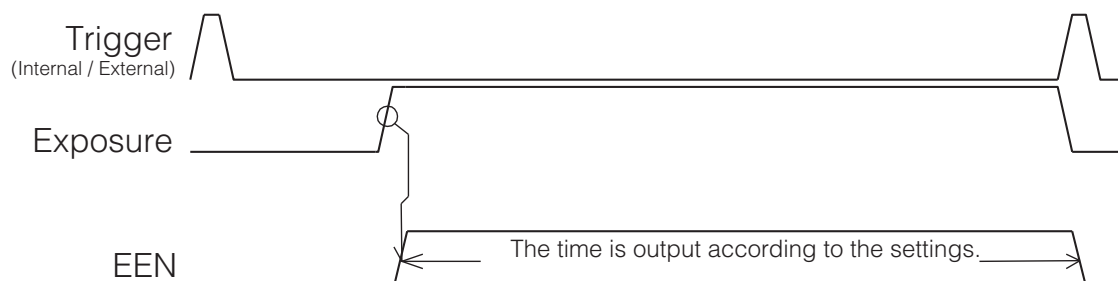

- ❖ The negative polarity is output to the DC IN / trigger IN connector (12-pin round), and the positive polarity is output to the DIGITAL I/O 1 video output connector (Camera Link). The polarities cannot be changed.

Test Pattern Function

You can display the following types of test patterns. Video output is not possible while a test pattern is being executed.

This function is not dependent on gain and offset values that have already been configured, and output is performed in the following states.

- ❖ Switching for this function is performed via serial communication.
- ❖ This function cannot be saved as the initial state of the camera.

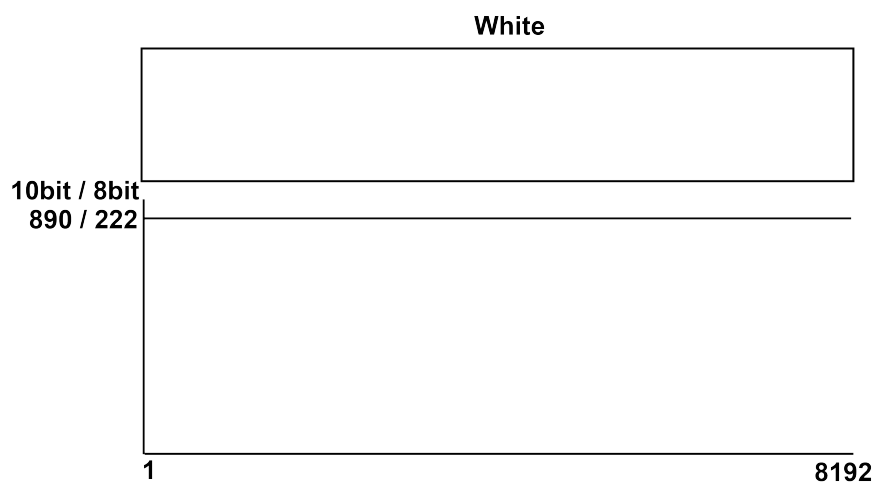
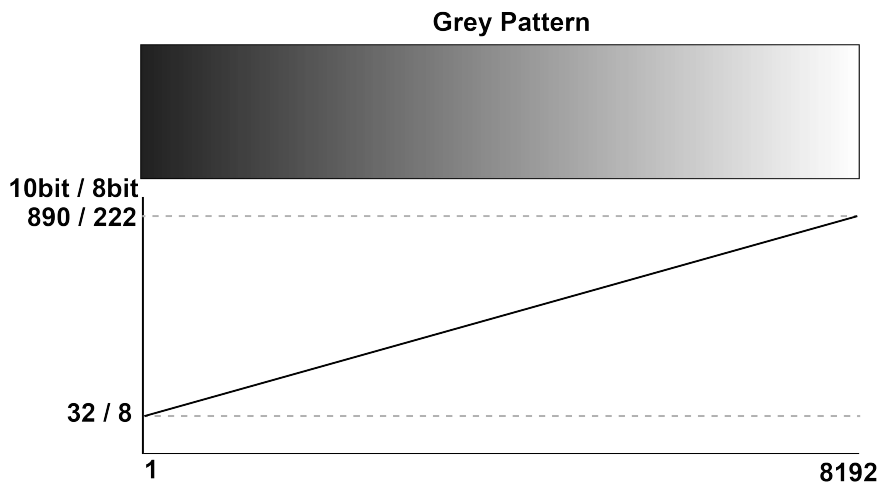
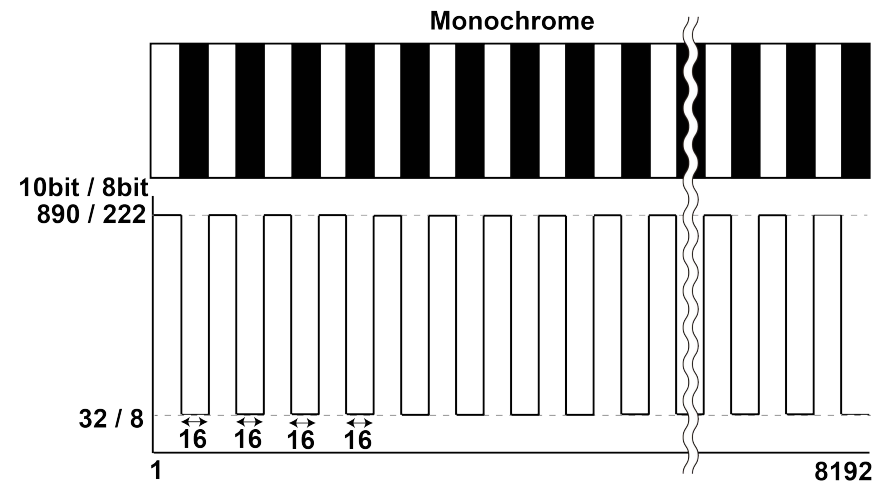

Binning

The binning function allows you to combine the signal values of clusters of adjacent pixels to create improved virtual pixels. Using the function results in images with lower pixel resolution and higher sensitivity.

This camera performs horizontal binning via digital addition or averaging processing.

This camera performs vertical binning via digital addition in the sensor.

RS-232C Command Control

The basic control parameters are as follows.

Item	Control parameter
Scanning	Independent scanning for all pixels, binning
Electronic Shutter	Accumulation time
Gain	Gain value
Black	Black offset value
Trigger	Mode, trigger polarity selection
Miscellaneous	Camera Link: 8- ↔ 10-bit switching Test pattern: ON ↔ OFF

Field Upgrade Function

You can update the firmware using the dedicated update tool via Camera Link serial communication.

❖ Serial communication via the DC IN / trigger IN connector (12-pin round) is not supported for this function.

Noise reduction digital filter function

This function reduces noise by applying a 1x3 median filter.

SNR can be improved, but it affects the sense of resolution and sensitivity. An imaging test should be performed before deciding to use this feature.

This function is enabled when [Media Filter] of [JAI Custom Control] is set to On.
(This function is disabled (Off) by default.)

Settings List

Control Tool

: Settings that can only be configured when image capture on the camera is stopped.

Item	Setting range	Default value	Description
a) Device Control			
GenCP Version	—	—	Display/configure information related to the device.
Device Vendor Name	—	"JAI Ltd., Japan"	Display the manufacturer name.
Device Model Name	—	SW-8000M-PMCL	Display the model name.
Device Manufacturer Info	—	"See the possibilities"	Display the manufacturer information.
Device Version	—	—	Display the device version.
Device ID	—	—	Display the device ID.
Device User ID	Any	—	Set the user ID for the camera.
Device Scan Type	Linescan	Linescan	Display the scan type of the camera.
Device Temperature Selector	Sensor	Sensor, Sensor Board Bottom, Interface Board Bottom, FPGA	Display the location of the temperature sensor inside the camera.
Device Temperature (Celsius)	—	—	Display the internal temperature (°C) of the camera.
Device Clock Selector	Camera Link	Camera Link	Select the camera clock.
Device Clock Frequency	84.82MHz, 63.39MHz, 42.41MHz, 31.70MHz	42.41MHz	Select the clock frequency for the camera.
Device Serial Port BaudRate	Baud 9600, Baud 19200, Baud 38400, Baud 57600, Baud 115200	Baud 9600	Select the baud rate for the camera's serial board.
Device Reset	—	—	Reset the device.
b) Image Format Control			
Pixel Format	Mono8 Mono10	Mono8	Set the pixel format.
Test Pattern	Off, Monochrome, GrayPattern, White	Off	Select the test image.
Binning Vertical	1, 2	1	Set the number of pixels in the vertical direction for which to perform binning.
Binning Horizontal	1, 2	1	Set the number of pixels in the Horizontal direction for which to perform binning.
Binning Horizontal Mode	Sum, Average	Sum	Set the addition process to be used during horizontal Binning.
c) Acquisition Control			
Trigger Selector	Line Start	Line Start	Select the trigger operation.
Trigger Mode	Off, On	Off	Select the trigger mode.
Trigger Source	CC1(Camera Link), Hirose 12Pin(TTL)	—	Select the trigger signal source.
Trigger Activation	Rising Edge, Falling Edge	Rising Edge (rising edge of input signal)	Select the polarity of the trigger signal (i.e., location of signal at which trigger is applied).
Trigger OverLap	Off	Off	Select the trigger overlap operation.
Acquisition Line Rate	66 to 10272 *1	10000	Set the line rate as a frequency. (unit: Hz)
Exposure Mode	Off, Timed	Timed (control via exposure time)	Select the exposure mode.
Exposure Time	3 to 97 *1	97	Set the exposure time. The maximum value when [Trigger Mode] is set to [Off] varies depending on the [Acquisition Line Rate Raw] value.
d) Analog Control			
Configure analog control settings.			

*1 Setting range depending on the Tap Geometry and CL Pixel Clock settings..

Item	Setting range	Default value	Description
Black Level Selector	All	All	
Black Level	-133 to 255	0	Set the black level value.
Gain Selector	Digital All	Digital All	
Gain	1 to 64	1	Set the gain value by multipliers.
Analog Base Gain	0dB, 6dB, 9.54dB, 12dB	0dB	Set the analog base gain.
e) LUT Control			Configure LUT settings.
JAI LUT Enable	Off, LUT, Gamma	Off	Select the JAI LUT mode.
Gamma	0.45 to 1	0.45	Set the gamma value.
LUT Selector	Luminance	Luminance	Display the LUT data type.
LUT Index	0 to 256	0	Set the LUT index table number.
LUT Value	0 to 4096	4096	Set the LUT value.
f) Transport Layer Control			Display information on the transport layer.
Device Tap Geometry	Geometry_1X2, Geometry_1X3, Geometry_1X4, Geometry_1X8, Geometry_1X10	Geometry_1X2	Set the transfer method (tap configuration) of images transferred from the camera at one time.
CL Configuration	Base, Medium, Full, EightyBit	Base	Display the Camera Link configuration.
CL Time Slots Count	One	One	Display the Camera Link time slot counter.
g) Digital IO Control			Configure settings for digital input/output.
Line Selector	Line1 - TTL Out	Line1 - TTL Out	Select the input/output to configure.
Line Mode	Output	Output	Display the input/output status (whether it is input or output).
Line Format	TTL	TTL	Display the current I/F type.
Line Source	Low, High, Exposure Active(XEEN), LVAL, Line4 - TTL In, Line7 - CC1	Exposure Active(XEEN)	Select the line source signal for the item selected in [Line Selector].
h) User Set Control			Configure user settings.
User Set Selector	Default, User Set1 to User Set3	Default (factory default values)	Select the user settings.
User Set Load	—	—	Load user settings.
User Set Save	—	—	Save the current setting values as user settings.
i) JAI Custom Control			Configure JAI proprietary function settings.
Auto Line Rate Reference			Set the reference value used when performing automatic level control using line periods.
Auto Line Rate	—	—	Adjust the line rate to achieve the brightness of the reference value. This functions only when [Exposure Mode] is set to [Off].
Auto Reset Mode	On, Off	Off	Set the Auto Reset Mode
Auto Internal Trigger	On, Off	Off	Set the Auto Internal Trigger.
Pixel Black Correct	Factory area, User area	User area	(DSNU) Select the area to which to save the black level correction value.
Pixel Black Detect			(DSNU) Execute pixel black correction.
Pixel Gain Correct	Factory area, User area	User area	(PRNU) Select the area to which to save the gain correction value.
Pixel Gain Detect			(PRNU) Execute pixel gain correction.
Shading Correct	Off, Factory area, User area	Off	Select the area to which to save the shading correction value.
Shading Detect			Execute shading detection.
Shading Detect Status	—	—	Display the status.
Pixel Gain Detect Status	—	—	(PRNU) Display the status.
Pixel Black Detect Status	—	—	(DSNU) Display the status.
Median Filter	Off, On	Off	Enable / Disable the noise reduction digital filter function.

Miscellaneous

Troubleshooting

Check the following before requesting help. If the problem persists, contact your local JAI distributor.

■ Power supply and connections

Problem	Cause and solution
The POWER/TRIG LED remains lit amber and does not turn green, even after power is supplied to the camera.	<ul style="list-style-type: none"> • A drop in voltage may have occurred due to the length of the power cable. Check whether input voltage specification for the camera is being met. • Check that the sufficient power is being provided at the power supply in regards to the camera's power usage. • Check the power cable connection.

■ Image display

Problem	Cause and solution
Gradation in dark areas is not noticeable.	Use the gamma function to correct the display. As the light-emitting properties of the monitor are not linear, the entire image may be darker or the gradation in the dark areas may be less noticeable when camera outputs are displayed without processing. Using the gamma function performs correction to produce a display that is close to linear. For details, see "LUT (Lookup Table) / Gamma Function" (page 32).

■ Settings and operations

Problem	Cause and solution
I want to restore the factory default settings.	To restore the factory default settings, select [Load settings] in the [Settings] menu of the [SW-4000M-PMCL Control Tool] window, select [Factory] in the dialog box that appears, and click [OK].

Specifications

Image sensor	Model	Custom
	Effective pixels	8192(H)
	Pixel size	3.75 μm \times 5.78 μm
Camera Link clock	31.875/42.5/63.75/85 MHz	
Line rate	66 Hz - 99.9 kHz	
Video S/N ratio	60 dB or more (when Gain = 0 dB) (10-bit)	
PRNU	Post-correction: Within $\pm 5\%$ (during 100% output)	
DSNU	Post-correction: Within $\pm 5\%$ (during 0% output)	
Gain	Analog Base Gain: 0 dB, 6 dB, 9.54 dB, 12 dB Digital: x1 to x64 (0 dB to +36 dB)	
Black level (user settings)	Manual -133 to +255 LSB (during 12-bit) Default setting: 0 Output black level (33LSB 10-bit)	
Image output	Digital video output (Camera Link) Base: 1 \times 2, 1 \times 3 Medium: 1 \times 4 Full: 1 \times 8 (8-bit) 80bit: 1 \times 8 (10-bit), 1 \times 10 (8-bit) ❖ Factory default values: 1 \times 2, 8-bit	
Variable line rate	Supported (for Exposure Mode OFF mode / internal trigger mode or Shutter select mode / internal trigger mode) Variable range: 66 Hz to 100 kHz Variable unit: 10 ns ❖ The black level may vary with longer line rates, due to the increase in dark currents.	
Electronic shutter	Supported (during shutter select mode) Variable range: 1.8 μs to 15.148 ms Variable unit: 1.0 μs	
Test pattern	Available 1: Gray 1 2: Gray 2 3: White (890LSB)	
Synchronization	Internal	
Image processing	① Pixel sensitivity correction: Pixel correction (DSNU, PRNU) ② Shading correction: ON/OFF switchable Flat Field correction possible. ③ LUT/Gamma function: 1.00 (OFF) / 0.45 / User (LUT) selectable When set to User, table data can be applied from externally. Table data can be configured individually.	
Operation mode	<ul style="list-style-type: none"> Exposure Mode OFF mode (Internal/External trigger) Shutter select mode (Internal/External trigger) PWC (External trigger) 	
Trigger inputs	12-pin: 3.5 \pm 1.5 V (p-p) TTL input Camera Link: LVDS (CC1) Positive / negative logic switchable. Minimum trigger width: EPS 3 μs or more / PWC 3 μs or more ❖ Use either 12-pin or Camera Link for trigger inputs.	
Synchronous output (when the terminal is open)	Camera Link	<ul style="list-style-type: none"> LVAL (Camera Link Tx24) DVAL (Camera Link Tx25) EEN (Camera Link Tx26)
	12-pin	<ul style="list-style-type: none"> XEEN (negative logic) 4.0 Vp-p (when there is no termination)
Communication interface	EIA-644: Camera Link CC1 RS-232C: 12-pin Communication rate: 9600 bps(Default), 19200bps, 38400bps, 57600bps, 115200bps	
Field update	Supported	

Power supply voltage	DC input range: +12 V to 24 V \pm 10% 5.22W typical (current consumption at DC +12 V supply)	
Lens mount	M42 mount, F mount	
Flange back	M42 mount: 16 mm (in air), tolerance: 0 mm to -0.05 mm F mount: 46.5 mm, tolerance: 0 mm to -0.05 mm	
Optical axis accuracy	Center \pm 0.5 mm (Max)	
Operating temperature / humidity	-5°C to +45°C / 20% to 80% (non-condensing)	
Storage temperature / humidity	-25°C to +60°C / 20% to 80% (non-condensing)	
Vibration resistance	10G (20 Hz to 200 Hz XYZ directions)	
Impact resistance	80G	
Standard compliance	CE (EN61000-6-2, EN61000-6-3) RoHS/WEEE FCC Part15 Class B	
Dimensions	62 x 62 x 84 mm (WHD) (F mount, excluding protrusions) 62 x 62 x 53.5 mm (WHD) (M42 mount, excluding protrusions)	
Weight	320 g	
Connectors / LEDs	Mini Camera Link	Model: HDR-EC26FYTG-SLT \times 2 Function: video output / communication / external trigger / EEN ❖ Positive polarity for EEN (polarity switching not possible)
	12-pin	Model: HR10A-10R-12PB (71) Function: power supply input / communication / external trigger / EEN ❖ Negative polarity for EEN (polarity switching not possible)
	Rear panel LED	Model: SPR-39MVWF Function: operation display / trigger input display

❖ In this document, the "X" in the XEEN represents the negative polarity.

Package contents

Camera body (1)
Sensor protection cap (1)
Dear Customer (sheet) (1)

Design and specifications are subject to change without notice.

Spectral Response

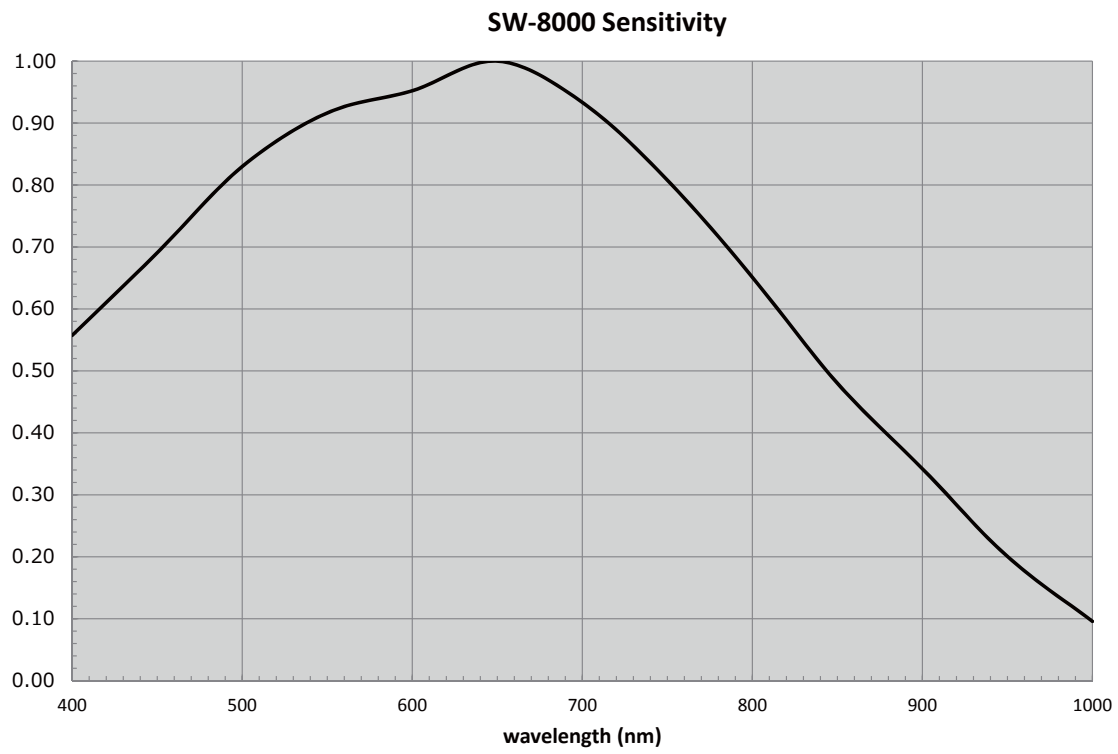

Dimensions

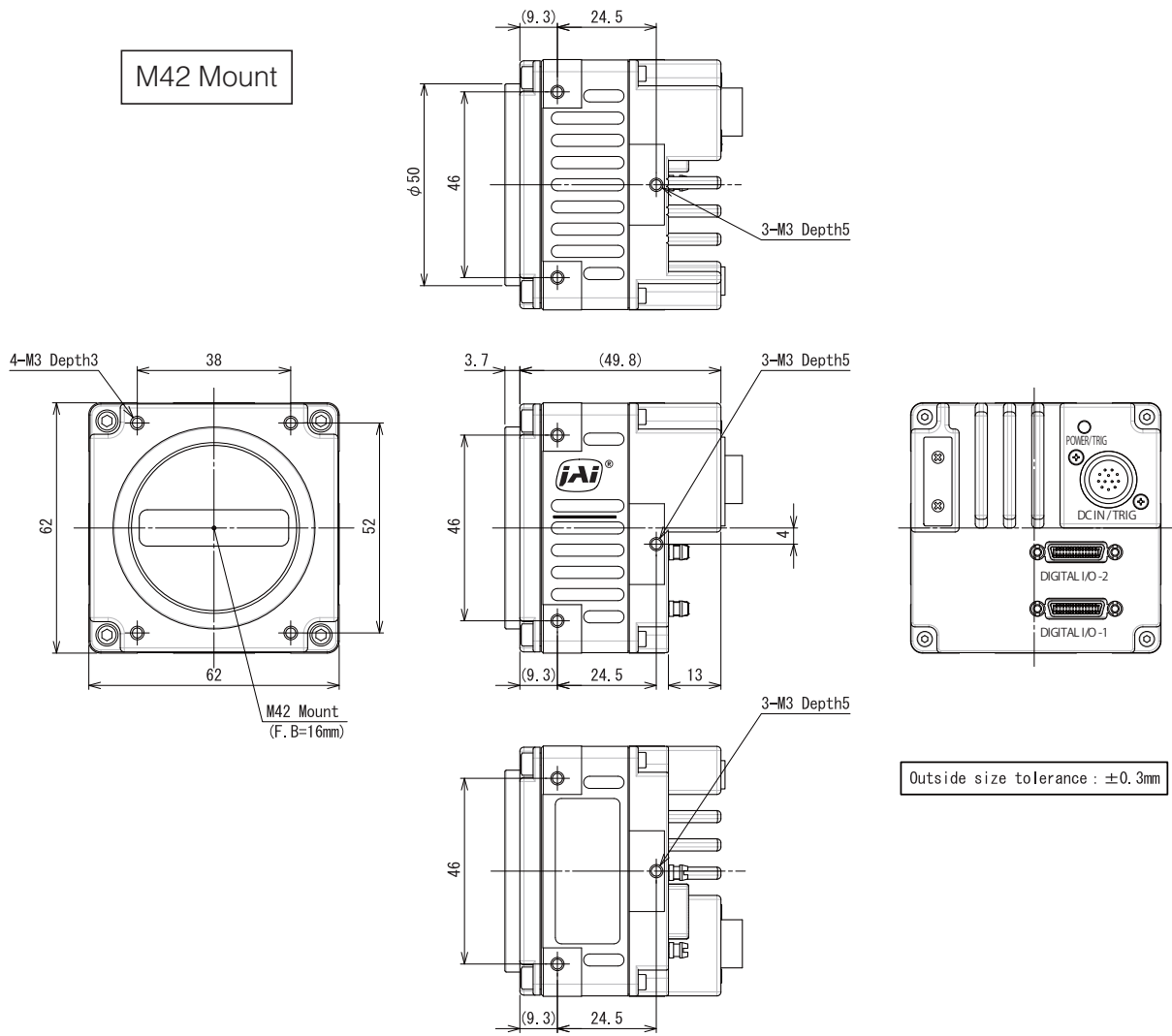

Outside size tolerance : ± 0.3 mm

Dimensional tolerance: ± 0.3 mm
Unit: mm

Trademarks

- Microsoft and Windows are trademarks or registered trademarks of Microsoft Corporation in the United States and other countries.
- Intel and Intel Core are trademarks of Intel Corporation in the United States and other countries.

Other system and product names described in this document are trademarks or registered trademarks of their respective owners. The ™ and © symbols are not used in this document.

Index

0-9		L	
12-pin round	8	LED	7
B		Lens	13
Binning Function	32	Lens mount	13
Black level	29	Lookup Table	28
C		LUT	28
Camera locking screw holes	9	O	
Connecting Devices	12	Output format	20
D		P	
DC IN	8	Parts Identification	7
DC IN/TRIG connector	8	POWER/TRIG LED	7
Digital Input/Output Settings	20	S	
Dimensions	39	Saving the Settings	17
E		Settings List	33
Exposure Mode	20	Shading Correction	29
G		Specifications	36
Gamma Function	28	Spectral Response	38
GPIO	20	T	
I		Trigger Control	21
Installing the Software	10	Troubleshooting	35
		U	
		User memory	17
		V	
		Verifying the Camera Connection Status	14

