



See the possibilities

Preliminary Version

User Manual

Sweep Series - CoaXPress Interface

SW-2005TL-CXP
SW-2005M-CXP



Digital CMOS Progressive Line Scan Camera (Trilinear and Monochrome)

Document Version: Preliminary

Date: 2024-12-27

Thank you for purchasing this product.

 Be sure to read this documentation before use.

This documentation includes important safety precautions and instructions on how to operate the unit. Be sure to read this documentation to ensure proper operation.

The contents of this documentation are subject to change without notice for the purpose of improvement.

Table of Contents

Table of Contents	2
About Technical Note	5
Notice/Warranty	6
Notice	6
Warranty	6
Certifications	6
CE Compliance	6
FCC	6
Warning	7
KC	7
China RoHS	8
Usage Precautions	9
Notes on Cable Configurations	9
Notes on Attaching the Lens	9
Phenomena Specific to CMOS Image Sensors	9
Notes on Exportation	10
Features	11
Package Contents, Accessories	11
Parts Identification	12
Lens Mount (C-Mount)	12
Connectors	12
DC IN/TRIG Connector (12-Pin Round)	13
CXP (CoaXPress) Connector	14
LEDs	14
Mounting Holes	16
Recommended External Input Circuit Diagram	16
Preparation	17
Step 1: Connect Devices	18
① Lens	18
② Mounting	19

③ CoaXPress cable	19
④ CXP Frame Grabber Board	19
⑤ DC IN / Trigger IN Connection Cable	19
⑥ AC Adapter (Power Supply, If Necessary)	19
Step 2: Verify Camera Operation	20
Step 3: Verify the Connection between the Camera and PC	20
Step 4: Configure Trigger, Exposure, and Line Rate Settings	21
Control via External Triggers with the Specified Exposure Time	22
Control via External Triggers without Specifying the Exposure Time	23
Control via External Triggers with Exposure Time Controlled by the Pulse Width of the Trigger Input Signal	24
Control without External Triggers with the Specified Exposure Time	25
Control without External Triggers without Specifying the Exposure Time	25
Step 5: Adjust the Image Quality	26
DSNU Correction (Pixel Black Correct)	26
PRNU Correction (Pixel Gain Correct)	27
Adjust the Gain	30
Adjust the White Balance	32
Adjust the Black Level	35
Step 6: Save the Settings	35
To Save User Settings	36
To Load User Settings	36
Main Functions	37
ROI (Regional Scanning Function)	37
Binning Function	38
Pixel Format	39
Acquisition Control	39
Change the Line Rate	39
Maximum Line Rates (Approximate)	40
Trigger Control	41
Image Output Delay	42
Exposure Mode	43

Actual Exposure Time	46
Delay Time from Trigger Input to Start of Exposure	47
GPIO (Digital Input/Output Settings)	48
LineSource Items	49
ExposureActive Signal	50
Pulse Generator	51
Gain Control	52
Gamma Function	53
LUT (Lookup Table)	54
Color Space Conversion (ColorTransformationControl)	55
Shading Correction	56
How to Configure the Shading Correction Function	57
Pixel Sensitivity Correction (DSNU, PRNU)	59
Chromatic Aberration Correction	60
Tilt View Correction	62
Noise Reduction Filter Functions	63
Spatial Compensation	64
Counter and Timer Control	65
Connecting Rotary Encoders	67
EncoderDivider Trigger Option	69
EdgeDetection Trigger Option	71
Resume Scanning (Backward Counter)	72
Rotation Direction	72
Logic Block Control	73
Setting List (Feature Properties)	74
DeviceControl	75
TransportLayerControl	77
ImageFormatControl	78
AcquisitionControl	79
DigitalIOControl	81
PulseGenerator	84
AnalogControl	86

LUT Control	88
Color Transformation Control	89
Shading	90
Correction	91
SpatialControl	94
Counter and Timer Control	95
EncoderControl	96
Logic Block Control	98
UserSetControl	99
Miscellaneous	100
Troubleshooting	100
Specifications	101
Spectral Response (SW-2005TL-CXP)	105
Spectral Response (SW-2005M-CXP)	105
Dimensions	106
Comparison of the Decibel Display and Multiplier Display	107
User's Record	108
Revision History	109

About Technical Note



Some additional technical information is provided on the JAI website as Technical Notes. In this manual, if a technical note is available for a particular topic, the above icon is shown. Please refer to the following URL for Technical notes.

<https://www.jai.com/support-software/technical-notes>

Notice/Warranty

Notice

The material contained in this manual consists of information that is proprietary to JAI Ltd., Japan, and may only be used by the purchasers of the product. JAI Ltd., Japan makes no warranty for the use of its product and assumes no responsibility for any errors which may appear or for damages resulting from the use of the information contained herein. JAI Ltd., Japan reserves the right to make changes without notice.

Company and product names mentioned in this manual are trademarks or registered trademarks of their respective owners.

Warranty

For information about the warranty, please contact your factory representative.

Certifications

CE Compliance

As defined by the Directive 2004/108/EC of the European Parliament and of the Council, EMC (Electromagnetic compatibility), JAI Ltd., Japan declares that SW-2005TL-CXP and SW-2005M-CXP comply with the following provisions applying to their standards.

EMI:EN55032:2015/A11:2020

EMS:EN55035:2017(CISPR35:2016)

FCC

This equipment has been tested and found to comply with the limits for a Class B digital device, pursuant to Part 15 of the FCC Rules. These limits are designed to provide reasonable protection against harmful interference in a residential installation. This equipment generates, uses and can radiate radio frequency energy and, if not installed and used in accordance with the instructions, may cause harmful interference to radio communications. However, there is no guarantee that interference will not occur in a particular installation. If this equipment does cause harmful interference to radio or television reception, which can be determined by turning the equipment off and on, the user is encouraged to try to correct the interference by one or more of the following measures:

- Reorient or relocate the receiving antenna.
- Increase the separation between the equipment and receiver.
- Connect the equipment into an outlet on a circuit different from that to which the receiver is connected.
- Consult the dealer or an experienced radio/TV technician for help.

Warning

Changes or modifications to this unit not expressly approved by the party responsible for FCC compliance could void the user's authority to operate the equipment.

KC

	상 호:	JAI Ltd. Japan
	기자재명칭:	Industrial Camera
	모 델 명:	SW-2005TL-CXP
	제조사 및 제조국가:	JAI Ltd., Japan / JAPAN
JAI-SW-2005M-CXP		

	상 호:	JAI Ltd. Japan
	기자재명칭:	Industrial Camera
	모 델 명:	SW-2005M-CXP
	제조사 및 제조국가:	JAI Ltd., Japan / JAPAN
JAI-SW-2005M-CXP		

제조년월은 제품상자의 라벨을 참조하십시오.

China RoHS

The following statement is related to the regulation on “Measures for the Administration of the Control of Pollution by Electronic Information Products”, known as “China RoHS”. The table shows contained Hazardous Substances in this camera.

 mark shows that the environment-friendly use period of contained Hazardous Substances is 15 years.

重要注意事项

有毒有害物质或元素名称及含量表

根据中华人民共和国信息产业部『电器电子产品有害物质限制使用管理办法』，本产品《有毒有害物质或元素名称及含量表》如下。

部件名称	有毒有害物质或元素					
	铅 (Pb)	汞 (Hg)	镉 (Cd)	六价铬 (Cr (VI))	多溴联苯 (PBB)	多溴二苯醚 (PBDE)
SW-2005TL-CXP	×	○	○	○	○	○
SW-2005M-CXP		○	○	○	○	○

○:表示该有毒有害物质在该部件所有均质材料中的含量均在 GB/T 26572-2011规定的限量要求以下。
 ×:表示该有毒有害物质至少在该部件的某一均质材料中的含量超出 GB/T 26572-2011规定的限量要求。

环保使用期限



电子信息产品中含有的有毒有害物质或元素在正常使用的条件下不会发生外泄或突变、电子信息产品用户使用该电子信息产品不会对环境造成严重污染或对其人身、财产造成严重损害的期限。

数字「15」为期限15年。

Usage Precautions

Notes on Cable Configurations

The presence of lighting equipment and television receivers nearby may result in video noise. In such cases, change the cable configurations or placement.

Notes on Attaching the Lens



Technical Notes

How to Clean a Sensor

Avoiding Dust Particles

When attaching the lens to the camera, stray dust and other particles may adhere to the sensor surface and rear surface of the lens. Be careful of the following when attaching the lens.

- Work in a clean environment.
- Do not remove the caps from the camera and lens until immediately before you attach the lens.
- To prevent dust from adhering to surfaces, point the camera and lens downward and do not allow the lens surface to come into contact with your hands or other objects.
- Always use a blower brush to remove any dust that adheres.
- Never use your hands or cloth, blow with your mouth, or use other methods to remove dust.

Phenomena Specific to CMOS Image Sensors

The following phenomena are known to occur on cameras equipped with CMOS image sensors. These do not indicate malfunctions.

- **Aliasing:** When shooting straight lines, stripes, and similar patterns, vertical aliasing (zigzag distortion) may appear on the monitor.
- **Blooming:** When strong light enters the camera, some pixels on the CMOS image sensor may receive much more light than they are designed to hold, causing the accumulated signal charge to overflow into surrounding pixels. This “blooming” phenomenon can be seen in the image but does not affect the operation of the camera.
- **Fixed pattern noise:** When shooting dark objects in high-temperature conditions, fixed pattern noise may occur throughout the entire video monitor screen.
- **Defective pixels:** Defective pixels (white and black pixels) of the CMOS image sensor are minimized at the factory according to shipping standards. However, as this phenomenon can be affected by the

ambient temperature, camera settings (e.g., high sensitivity and long exposure), and other factors, be sure to operate within the camera's specified operating environment.

Notes on Exportation

When exporting this product, please follow the export regulations of your country or region.

Features

This camera is a linescan camera using trilinear (RGB) and monochrome CMOS line sensors. It has a small (44mm × 44mm × 54mm), lightweight (SW-2005TL-CXP: 154g; SW-2005M-CXP: 153g) design with a CoaXPress v2.0, CXP-6 interface.

Model Name	Image Sensor	Effective Pixels	Pixel Size	Max Line Rate
SW-2005TL-CXP	Trilinear (RGB)	2048 x 3	7.0µm x 7.0µm	44kHz
SW-2005M-CXP	Mono	2048 x 1	7.0µm x 7.0µm	172kHz

Features Overview

- Interface: CoaXPress v2.0, CXP-6 (6.25 Gbps)
- Supports direct encoder connection to camera
- Wide variety of trigger options
- Provides all the features a line scan camera needs: PRNU, DSNU, Spatial Compensations*, White Balance*, Shading Correction, Binning, Master/Individual Gain Mode*, LUT, Color Space Conversion*

Notes:

- *Color model only
- For more information on the functions supported by this camera, see the [Main Functions](#) chapter.

- Excellent shock and vibration resistance
- Support the PoCXP function
- C-mount lens mount

Package Contents, Accessories

- Camera (1)
- Sensor Protection Cap (1)
- Dear Customer Sheet (1)

Optional Accessories (Sold Separately)

- AC Adapter

Parts Identification

Note: See "[Dimensions](#)" for external view of the entire camera.

Lens Mount (C-Mount)

Mount a C-mount lens here.

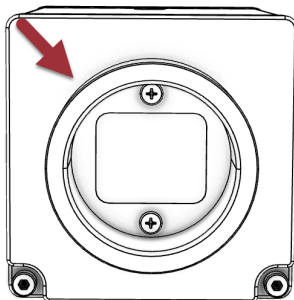

Note: Before mounting a lens, be sure to refer to [① Lens](#) and confirm the precautions for attaching a lens and the supported lens types.

Connectors

This section displays the pin assignments for each connector.

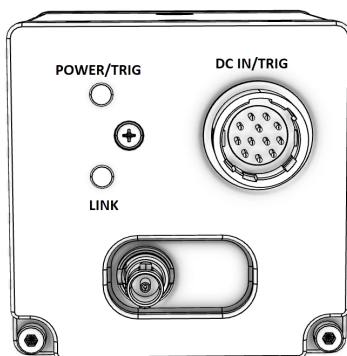

DC IN/TRIG Connector (12-Pin Round)

Related Setting Items: [DigitalIOControl](#)

Connect the cable for a power supply or for DC IN / trigger IN here.

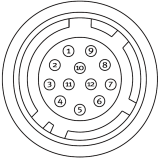
 <p>PN: HR10A-10R-12PB (71)</p>	Pin No.	Input/Output	Signal	Description
	1		GND	
	2	Power In	DC In	DC 10.8 ~ 26.4V
	3		GND	
	4	In	TTL In 4	Line 14
	5	In	Opto In 1 -	Line 5
	6	In	Opto In 1 +	
	7	Out	TTL Out 4	Line 12
	8		NC	
	9	Out	TTL Out 1	Line 1
	10	In	TTL In 1	Line 4
	11	Power In	DC In	DC 10.8 ~ 26.4V
12		GND		

Note: The pin assignment of this camera is different from other JAI cameras.

TTL Signal Specification

TTL out signal specification (Typ.)	Output voltage: Low 0.0V, High 5.0V
TTL in signal specification (Typ.)	Input voltage: Low 0.0 ~ 0.7V, High 2.0 ~ 5.5V

CXP (CoaXPress) Connector

Coaxial cable for digital video output.

Note: This camera supports the PoCXP function.

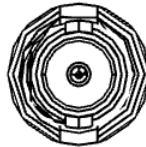

- **Connector:** Micro-BNC
- **CxpLinkConfiguration:** CXP6_X1, CXP3_X1

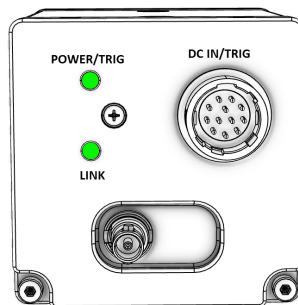

Note: You can check the current CXP version in **CxpVersion Used** [[TransportLayerControl](#)]. Even if you are using a CoaXPress frame grabber board that supports CXP 2.0, if CxpVersionUsed is CXP 1.1, you may need to make settings on the frame grabber board side. For the specific setting method, refer to the instruction manual of the frame grabber board to be used.

LEDs











The table below shows the LED light and camera status.

POWER TRIG

Light		Status
	Lit amber	Camera initializing.
	Lit green	Camera in operation.

Light		Status
	Blinking green	<p>During operation in trigger mode, trigger signals are being input.</p> <p>Note: The blinking interval is not related to the actual input interval of the external trigger.</p>

LINK

Light		Status
	Off	The network link is not established (or is in progress).
	Lit amber	System is powering up.
	Red pulse - slow	<p>No connection.</p> <p>Note: Not applicable when using PoCXP.</p>
	Alternating between green and amber - rapid	<p>When using PoCXP: Detecting link.</p> <p>Note: Blinks for 1 second even when detected immediately.</p>
	Blinking amber - rapid	<p>When not using PoCXP: Detecting link.</p> <p>Note: Blinks for 1 second even when detected immediately.</p>
	Lit green	Connection between device and host is established, but there is no data being transmitted.
	Blinking amber - slow	Established connection between camera and frame grabber. Waiting for an event (trigger, exposure pulse, etc.)
	Blinking green - rapid	Established connection between camera and frame grabber. Data is being transmitted.
	Alternating between green and amber - slow	Sending connection test packet.

Mounting Holes

Use these holes to mount the camera directly to a structural system.

Location	Available Mounting Holes
Top	M3, Depth 3mm x 4
Bottom	M3, Depth 3mm x 4

Note: Refer to "[Dimensions](#)" for the location of the mounting holes.

Recommended External Input Circuit Diagram

Reference Example

Caution: Check the recommended external input circuit diagram (reference example) and connect correctly.

Note: Parts may be replaced with equivalent products.

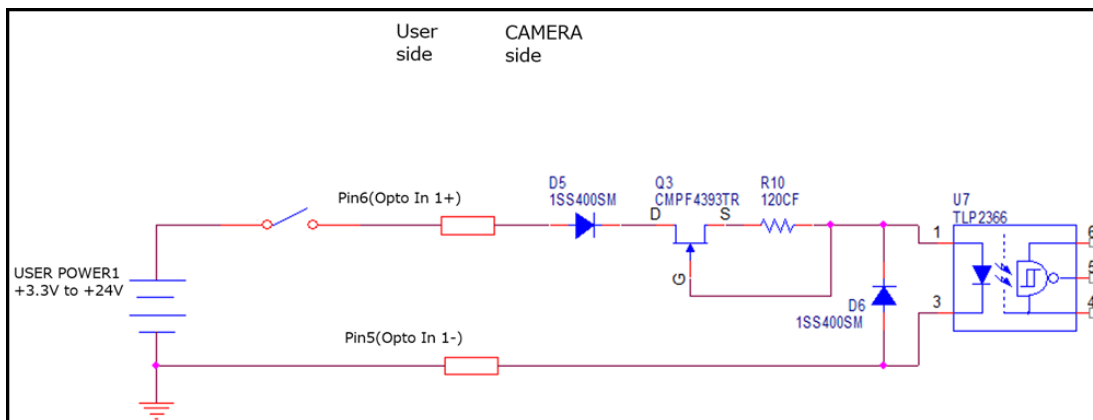

Preparation

Read this section to learn how the camera connects to devices and accessories. The preparation process is described below.

Note: eBUS Player for JAI does not support this camera.

1	<u>Step 1: Connect Devices</u> Connect the lens, cables, AC adapter, computer, and other devices.
2	<u>Step 2: Verify Camera Operation</u> Verify whether the camera is turned on and ready for use.
3	<u>Step 3: Verify the Connection between the Camera and PC</u> Verify whether the camera is properly recognized via Control Tool.
4	<u>Step 4: Configure Trigger, Exposure, and Line Rate Settings</u> Refer to the procedure for changing the output format setting as an example and change various settings as necessary.
5	<u>Step 5: Adjust the Image Quality</u> Refer to the procedures for adjusting image quality.
6	<u>Step 6: Save the Settings</u> Save the current setting configurations in user memory.

Step 1: Connect Devices

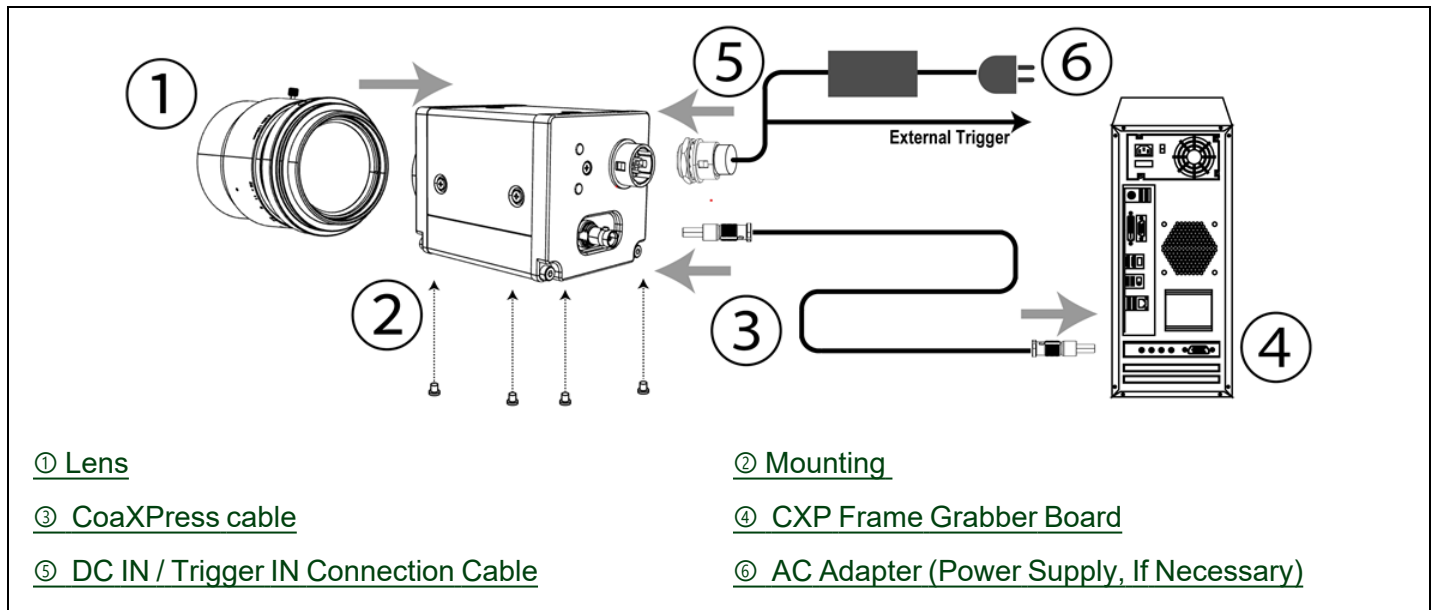

① Lens

C-mount lenses with lens mount protrusions of 9 mm or less can be attached.

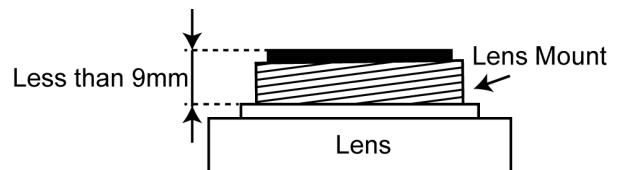

Cautions:

- The maximum performance of the camera may not be realized depending on the lens.
- Attaching a lens with a mount protrusion of 9 mm or longer may damage the lens or camera.

Notes:

The following formula can be used to estimate the focal length.

$$\text{Focal length} = \text{WD} / (1 + \text{W}/\text{w})$$

WD: Working distance (distance between lens and object)

W: Width of object

w: Width of sensor

② Mounting

When mounting the camera directly to a device, use screws that match the mounting holes on the camera. For more information on the mounting holes, see "[Mounting Holes](#)".

Caution: For heavy lenses, be sure to support the lens itself. Do not use configurations in which its weight is supported by the camera.

③ CoaXPress cable

Connect the CoaXPress cable to the CXP connector on the camera and frame grabber board. Refer to the specifications of the cable for details on its bend radius.

④ CXP Frame Grabber Board

Refer to the operating instructions of the frame grabber board, and configure settings on the computer as necessary.

⑤ DC IN / Trigger IN Connection Cable

Performs external I/O such as power supply and trigger input.

⑥ AC Adapter (Power Supply, If Necessary)

Connect the AC adapter and the round connector of the connection cable to the DC IN / trigger IN connector on the camera.

Step 2: Verify Camera Operation

When power is supplied to the camera while the necessary equipment is connected, the POWER/TRIG LED at the rear of the camera lights amber, and initialization of the camera starts. When initialization is complete, the POWER/TRIG LED lights green.

Verify whether power is being supplied to the camera by checking the rear LED. When properly turned on, the POWER/TRIG LED is lit green.

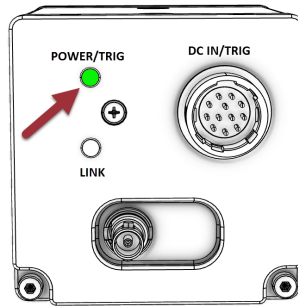

Note: For details on how to read the LEDs, see the [LEDs](#) section.

Step 3: Verify the Connection between the Camera and PC

Use the appropriate tool for the CoaXPress frame grabber board to be used to set up the camera and display captured images. Refer to the operation manual of the tool to be used for the operation method.

Note: eBUS Player for JAI does not support this camera.

Step 4: Configure Trigger, Exposure, and Line Rate Settings

Related Setting Items: [AcquisitionControl](#)

This section describes five scenarios for controlling the trigger, exposure, and line rate.

Note: This section is intended to explain the basic relationship between the trigger, exposure, and line rate.

Trigger	Exposure	Setting Example
On	Timed	<u>Control via External Triggers with the Specified Exposure Time</u>
	TriggerWidth	<u>Control via External Triggers with Exposure Time Controlled by the Pulse Width of the Trigger Input Signal</u>
	Off	<u>Control via External Triggers without Specifying the ExposureTime</u>
Off	Timed	<u>Control without External Triggers with the Specified Exposure Time</u>
	Off	<u>Control without External Triggers without Specifying the Exposure Time</u>

Control via External Triggers with the Specified Exposure Time

In the example below, **TriggerSelector** is set to **LineStart**.

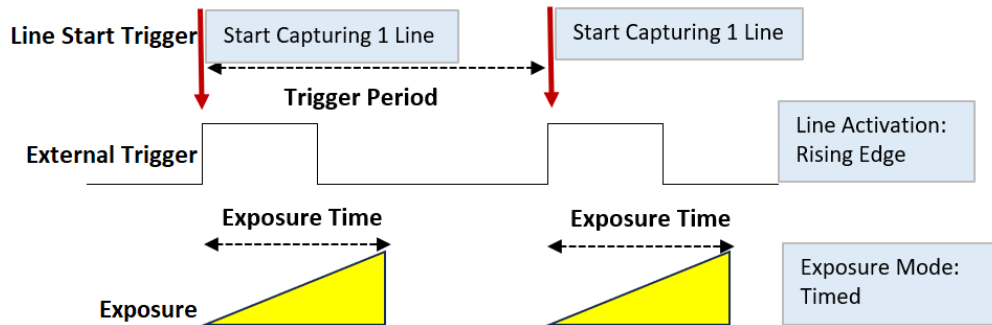

Notes:

- When using external triggers, the line rate is determined by the trigger period.
- The ExposureTime value cannot be longer than the trigger period.

Item	Setting
Trigger Mode	On
Trigger Selector	Line Start
Trigger Source	Any
Trigger Activation	RisingEdge (rising edge of input signal) or FallingEdge (falling edge of input signal)
Exposure Mode	Timed (control via exposure time)
Exposure Time	Varies depending on settings.

Control via External Triggers without Specifying the ExposureTime

In the example below, **TriggerSelector** is set to **LineStart**.

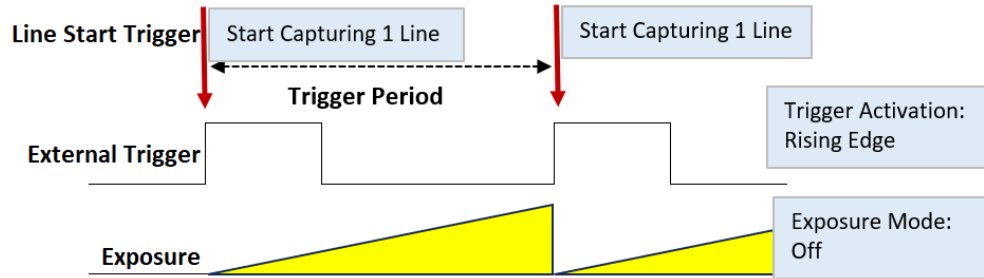

Notes:

- When using external triggers, the line rate is determined by the trigger period.
- The exposure is performed with an exposure time calculated from $1 / (\text{line rate})$.

Item	Setting
Trigger Mode	On
Trigger Selector	Line Start
Trigger Source	Any
Trigger Activation	RisingEdge (rising edge of input signal) or FallingEdge (falling edge of input signal)
Exposure Mode	Off

Control via External Triggers with Exposure Time Controlled by the Pulse Width of the Trigger Input Signal

In the example below, **TriggerSelector** is set to **LineStart**.

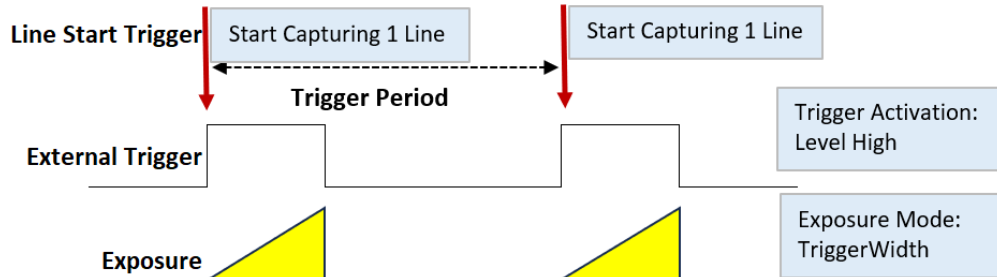

Notes:

- When using external triggers, the line rate is determined by the trigger period.

Item	Setting
Trigger Mode	On
Trigger Selector	Line Start
Trigger Source	Any
Trigger Activation	LevelHigh (high-level duration) or LevelLow (low-level duration)
Exposure Mode	TriggerWidth (control via trigger width)

Control without External Triggers with the Specified Exposure Time

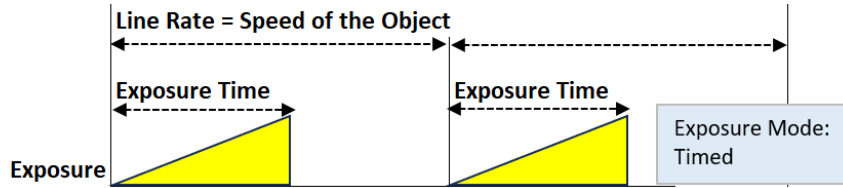

Notes:

- ExposureTime can be set up to 1 line cycle to match the speed of the object or to lengthen the accumulation time to increase sensitivity.
- The ExposureTime value cannot be longer than the line period.

Item	Setting
Trigger Mode	Off
Exposure Mode	Timed (control via exposure time)
Exposure Time	Varies depending on settings.
Acquisition Line Rate	The maximum value varies depending on PixelFormat, ROI, Link Speed, etc.

Control without External Triggers without Specifying the Exposure Time

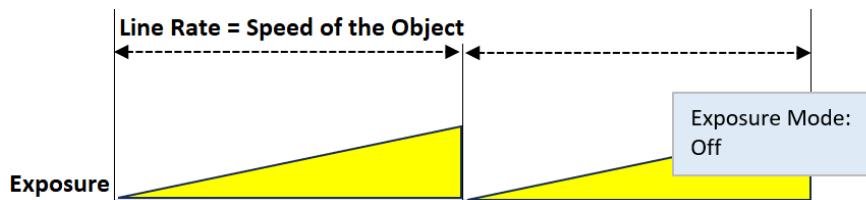

Notes:

- The line rate can be set up to 1 line cycle to match the speed of the object or to lengthen the accumulation time to increase sensitivity.
- The exposure is performed with an exposure time calculated from $1 / (\text{line rate})$.

Item	Setting
Trigger Mode	Off
Exposure Mode	Off
Acquisition Line Rate	The maximum value varies depending on PixelFormat, ROI, Link Speed, etc.

Step 5: Adjust the Image Quality

Use the following steps to adjust the image quality of this camera.

1. [DSNU Correction \(Pixel Black Correct\)](#)
2. [PRNU Correction \(Pixel Gain Correct\)](#)
3. [Adjust the Gain](#)
4. [Adjust the White Balance](#) (Color model only)
5. [Adjust the Black Level](#)

DSNU Correction (Pixel Black Correct)

Related Setting Items: [Correction](#)

DSNU (dark signal non-uniformity) is a variation between pixels in the dark areas generated by the sensor. If the line rate is slowed or a long exposure time is set, the dark current in the sensor may change and the state of the DSNU may change.



How to Configure

1. Place the sensor protection cap on the camera.
2. Start image acquisitions with AcquisitionStart [[AcquisitionControl](#)].
3. Specify the user area (User1 ~ User3) to save the black level correction value with **PixelBlackCorrectionMode** ([Correction](#)).

Note: Default saves the correction data set at the factory. You cannot overwrite this data.

4. Execute **CalibratePixelBlackCorrection**. Black level correction data is automatically generated and saved in the user area specified in PixelBlackCorrectionMode.
5. You can check the execution result of black level correction on **PixelBlackCalibrationResult**.

Result	Description
Succeeded	The correction has been successfully completed. The correction data has been saved to the user area specified in PixelBlackCorrection.

Result	Description
Error1 - Image was too bright	Correction failed. The image was too bright.
Error2 - Image was too dark	Correction failed. The image was too dark.
Error3 - Could not calibrated	<p>Could not perform the correction because the camera is in one of the following status:</p> <ul style="list-style-type: none"> • The image is not being output. • TestPattern[ImageFormatControl] is set to anything other than Off. • PixelBlackCorrectionMode is set to Off or Default.

PRNU Correction (Pixel Gain Correct)

Related Setting Items: [Correction](#)

PRNU (photo response non-uniformity) is a variation between pixels generated by the sensor under bright conditions. If the line rate is slowed or a long exposure time is set, the dark current in the sensor may change and the state of the PRNU may change.



PRNU Correction Modes (PixelGainCorrectionMode)

This camera supports the following PRNU correction modes. The difference is the area in which PRNU is performed. In all modes, if the image to be corrected is too bright or too dark, the camera performs the correction as close as possible to the target level (= best effort correction).

PixelGainCorrectionMode	Area to Calculate Correction Data	Area to Apply Correction
User1, User2, User3	Entire area (full ROI)	Entire area (full ROI)
SelectedROI	Area specified by the ROI settings	Area specified by the ROI settings

Note: For details on ROI, see "[ROI \(Regional Scanning Function\)](#)".

How to Execute

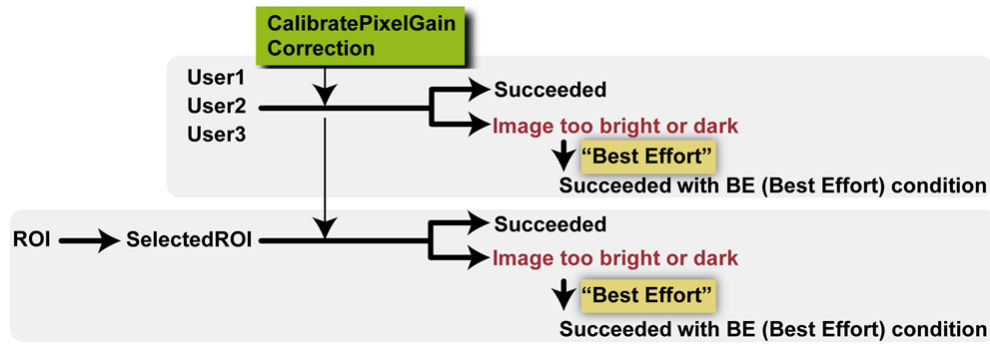

Notes:

- The video level should be between 70% and 90% of the saturation level. The sensor must be uniformly illuminated. If a lens is attached to the camera, it must be defocused.
- PRNU correction is performed under the condition that the image is flat with or without a lens attached. However, if there is shading due to a lens, light sources, etc., correction is performed to flatten the image including the effects of such shading.
- The subject should be a white, flat surface (such as a sheet of white paper).

1. If you perform PRNU only on the user-specified ROI, configure the **Width** and **OffsetX** values [[ImageFormatControl](#)].
2. Specify the setting (User1, User2, User3, or SelectedROI) to save the gain correction value in **PixelGainCorrectionMode** ([Correction](#)). For detailed information on each correction setting, see the "PRNU Correction Modes (PixelGainCorrectionMode)" section.

Note: Default saves the correction data set at the factory. You cannot overwrite this data.

3. Execute **CalibratePixelGainCorrection** and correct the image. Gain correction data is automatically generated and saved in the area specified in **PixelGainCorrectionMode**. Then, the calibration result "Succeeded" is displayed in **PixelGainCalibrationResult**.
4. If the image is too bright or too dark, the camera makes the correction as close as possible to the target level ("Best Effort" correction), and displays the following result in **PixelGainCalibrationResult**.

The table below shows a list of the calibration result:

Result	PixelGain CorrectionMode	Description
Idle	Any	Correction has not been performed.

Result	PixelGain CorrectionMode	Description
Succeeded	User1, User2, or User3	Correction was completed successfully. The correction data calculated from the full ROI has been applied to the entire area and saved in the user area specified in PixelGainCorrectionMode.
	SelectedROI	Correction was completed successfully. The correction data calculated from the specified ROI was applied to the ROI are and saved in SelectedROI.
Succeeded with BE condition	User1, User2, or User3	Correction was performed as close as possible to the target level in the entire area because the brightness of the entire area was outside the range for which normal correction can be performed. The correction data has been saved in the user area specified in PixelGainCorrectionMode.
	SelectedROI	Correction was performed as close as possible to the target level in the area specified by the ROI because the brightness of the specified area was outside the range for which normal correction can be performed. The correction data has been saved SelectedROI.
Error3 - Could not calibrated	Any	<p>Could not perform the correction due to one of the following reasons:</p> <ul style="list-style-type: none"> • The image is not being output. • TestPattern[ImageFormatControl] is set to anything other than Off. • PixelGainCorrectionMode is set to Off or Default.

Adjust the Gain

Related Setting Items: [AnalogControl](#)

Note: For details on gain control, see “[Gain Control](#)” in the Main Functions chapter.

Manual Adjustment

Monochrome Model:

1. If you want to disable the camera's internal fixed gain (= InGain) and only enable the user-set gain, set **InGainBypassMode** to **On** (default = Off).
2. Configure the Gain value (DigitalAll) in **Gain**.

Color Model: Two digital gain control modes are available: a mode in which the master gain is adjusted and fine adjustments are made for R and B (Master Mode), and a mode in which the gain can be adjusted for each RGB separately (Individual Mode).

- **MasterMode:**

1. Set **IndividualMode** to **Off**.
2. Select the DigitalGain (DigitalAll, DigitalRed, DigitalBlue) you want to configure from **GainSelector**.
3. Configure the Gain value in **Gain**.

- **IndividualMode:**

1. Set **IndividualMode** to **On**.
2. If you want to disable the camera's internal fixed gain (= InGain) and only enable the user-set gain, set **InGainBypassMode** to **On** (default = Off).
3. Select the DigitalGain (DigitalRed, DigitalGreen, DigitalBlue) you want to configure from **GainSelector**.
4. Configure the Gain value in **Gain**.

Automatic Adjustment

This camera can automatically adjust the gain. However, for color models, **IndividualGainMode** must be set to **Off** to use the automatic gain adjustment function.

1. Color model only: Set **IndividualMode** to **Off**.
2. If necessary, use **GainAutoWidth** and **GainAutoOffset** to configure the Gain adjustment area.
3. Configure **AGCReference** to set the convergence level.
4. Set **GainAuto** to **Once**.
5. The Gain value is automatically adjusted. After the adjustment, GainAuto returns to Off.
6. The adjustment status can be checked in **AGCOnceStatus**.

Result	Description
Idle	Adjustment is not being performed.
Processing	Adjustment is being performed.
Succeeded	Adjustment was completed successfully. After the adjustment, GainAuto returns to Off.
Error3 - Timeout	Adjustment failed. Adjustment was repeated for 10 seconds without success.
Error4 - could not processing	Could not perform the adjustment due to one of the following reasons: <ul style="list-style-type: none"> • The image is not being output. • TestPattern[ImageFormatControl] is set to anything other than Off.

Adjust the White Balance

Related Setting Items: [AnalogControl](#)

Adjust the white balance using the automatic adjustment function.

Note: This function is only supported on the color model.

Automatic Adjustment Modes

This camera provides the following two modes for automatic white balance adjustment.

BalanceWhiteAuto	Adjustment Area	When Normal Correction Cannot Be Performed
Once	Area specified by BalanceWhiteAutoWidth and BalanceWhiteAutoOffsetX	Adjustment is aborted
OnceUserAreaBE	Entire Area	Adjust the white balance as close as possible to the target level (Best Effort calibration).

Note: "OnceUserAreaBe" is a "Best Effort" calibration method. The white balance may not be perfect when this option is selected due to extremely unbalanced illumination of the target object. For example, when the lighting does not emit any red photons, a fully balanced image output cannot be achieved, but green and blue will be balanced after the adjustment.

How to Configure Automatic White Balance Adjustment

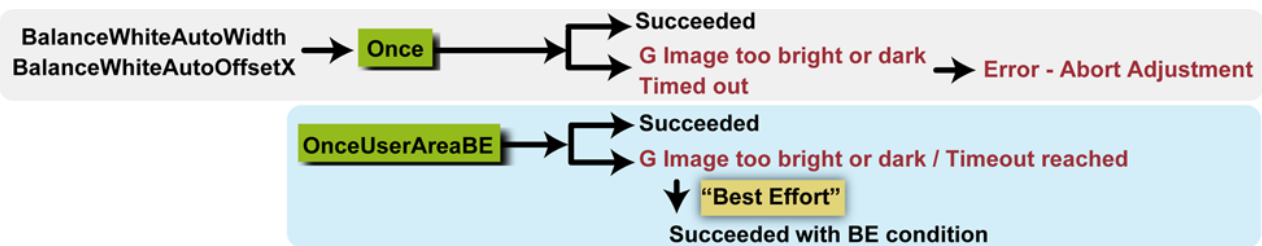

1. Place a white/gray White Balance target in front of the camera, at the same position as the inspected object. Ensure that the White Balance target fills the whole image or ROI used (if UserArea is used).
2. If necessary, use **BalanceWhiteAutoWidth** and **BalanceWhiteAutoOffsetX** to configure the white balance adjustment area.
3. Set **BalanceWhiteAuto** to **Once** or **OnceUserAreaBe**. For more information, see "Automatic Adjustment Modes".

Notes:

- When **BalanceWhiteAuto** is set to **Off**, the white balance cannot be adjusted automatically. Manually adjust the white balance using **Gain**[[AnalogControl](#)].
- When **IndividualGainMode**[[AnalogControl](#)] is set to **On**, **BalanceWhiteAuto** is forced to **Off**.
- The **BalanceWhiteAutoWidth** and **BalanceWhiteAutoOffsetX** settings apply only to the Once option. When **OnceUserAreaBe** is selected, the **BalanceWhiteAutoWidth** and **BalanceWhiteAutoOffsetX** settings are ignored.

4. The white balance is automatically adjusted. After the adjustment, "**Succeeded**" is displayed in **BalanceWhiteAutoResult**. Once the adjustment is completed, **BalanceWhiteAuto** returns to **Off**.
5. When normal correction cannot be performed, or if the white balance adjustment fails after 10 seconds of repeated attempts, the camera operates differently depending on the selected **BalanceWhiteAuto** setting.
 - **Once**: The adjustment attempt fails. An error message is displayed in **BalanceWhiteAutoResult** (for more information, see the "BalanceWhiteAutoResult" section below).
 - **OnceUserAreaBe**: The camera continues to adjust the whitebalance as close as possible to the target level until the timeout period is reached.

Once the adjustment is complete, "Succeeded with BE condition" is displayed in **BalanceWhiteAutoResult**.

Note: On this camera, the white balance can also be set to "Color Temperature" (**Preset5000K**, **Preset6500K**, **Preset7500K**). When using the Color Temperature option, **IndividualGainMode** [[AnalogControl](#)] must be set to **Off**.

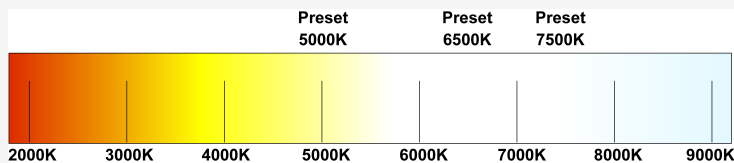

BalanceWhiteAutoResult

A list of calibration results when **BalanceWhiteAuto** is set to **Once** or **BalanceWhiteAuto** is shown below.

Result	BalanceWhiteAuto	Description
Idle	Any	Adjustment is not being performed.
Processing	Any	Adjustment is being performed.
Succeeded	Once	Adjustment was completed successfully to the area specified by BalanceWhiteAutoWidth and BalanceWhiteAutoOffsetX . After the adjustment, BalanceWhiteAuto returns to Off.
	OnceUserAreaBE	Adjustment was completed successfully for the entire area. After the adjustment, BalanceWhiteAuto returns to Off.
Succeeded with BE condition	OnceUserAreaBE	Adjusted the white balance as close as possible to the target level. Could not perform normal adjustment because the Red and/or Blue levels in the entire image were too high or too low compared to the Green level.
Error1 - G image was too bright	Once	Adjustment failed. The Green level in the area specified by BalanceWhiteAutoWidth and BalanceWhiteAutoOffsetX was too high compared to the Red or Blue level.
Error2 - G image was too dark	Once	Adjustment failed. The Green level in the area specified by BalanceWhiteAutoWidth and BalanceWhiteAutoOffsetX was too low compared to the Red or Blue level.
Error3 - Timeout	Once	Adjustment failed. Adjustment was repeated for 10 seconds without success.
Error4 - Target level was too high	Once	Adjustment failed. The target level was too high.
Error5 - Target level was too low.	Once	Adjustment failed. The target level was too low.

Adjust the Black Level

Related Setting Items: [AnalogControl](#)

1. Select the black level you want to configure in **BlackLevelSelector**.
 - Monochrome model: All (Master black) only
 - Color model: All (Master black), Red, Blue
2. Specify the adjustment value in **BlackLevel**.

Step 6: Save the Settings

Related Setting Items: [UserSetControl](#)

The configured setting values will be deleted when the camera is turned off. By saving current setting values to user memory, you can load and recall them whenever necessary. You can save up to three sets of user settings in the camera. (User Set1 to 3)

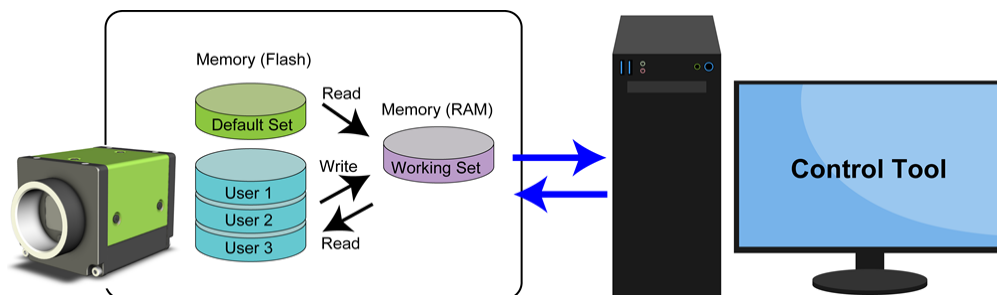

Note: Changes to settings are not saved to the computer (Control Tool).

To Save User Settings

1. Stop image acquisition.
2. Expand **UserSetControl** and select the save destination (UserSet1 to UserSet3) in UserSetSelector.

Note: The factory default setting values are stored in Default and cannot be overwritten.

Caution: Settings can only be saved when image acquisition on the camera is stopped.

3. Select **UserSetSave** and click the **UserSetSave** button.
4. The current setting values are saved as user settings.

To Load User Settings

1. Stop image acquisition. User settings can only be loaded when image capture on the camera is stopped.
2. Select the settings to load (UserSet1 to UserSet3) in UserSetSelector.
3. Select **UserSetLoad** and click the **UserSetLoad** button.
4. The selected user settings are loaded.

Note: When selecting **Default**, the factory settings are loaded.

Main Functions

This chapter describes the camera's main functions.

ROI (Regional Scanning Function)

Related Setting Items: [ImageFormatControl](#)

The ROI (region of interest) function allows you to output images by specifying the area to scan.

ROI Settings

Specify the area to scan by specifying the Width and Horizontal offset value ([ImageFormatControl](#)).

Note: On this camera, Height is fixed to 1.

The setting ranges for the ROI function's readable area based on the Binning setting (BinningHorizontal) are as follows.

	Binning = Off	Binning = On
Width (pixels)	128 ~ (2048 - OffsetX), step 8	64 ~ (1024 - Offset X), step 8
OffsetX (pixels)	0 ~ (2048 - Width), step 8	0 ~ (1024 - Width), step 8

ROI Examples

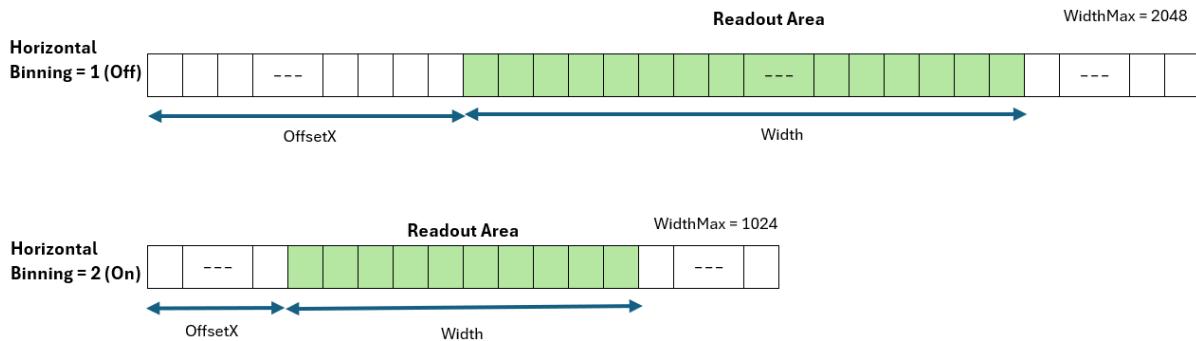

For example, when **OffsetX** is set to 8, the first readout pixel is the 9th pixel.

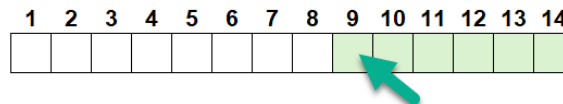

Binning Function

Related Setting Items: [ImageFormatControl](#)

The Binning function allows you to combine the signal values of clusters of adjacent pixels to create improved virtual pixels. Using the function results in images with a lower pixel resolution and higher sensitivity in summing mode (Sum) or reduced noise in averaging mode (Average).

Notes:

- This camera supports Horizontal x2 digital binning on the FPGA.
- For the relationship between this function and the line rate, see "Max Line Rate (Approximate)".

Setting	Pixel Size, Resolution	Image Example
1 (Off)	<p>7.0 μm ... 2048 resolution</p>  <p>7.0 μm Trilinear</p>	
	<p>7.0 μm ... 2048 resolution</p>  <p>7.0 μm Mono</p>	
2 (On)	<p>14.0 μm ... 1024 resolution</p>  <p>7.0 μm Trilinear</p>	 <p>(Sum Mode)</p>
	<p>14.0 μm ... 1024 resolution</p>  <p>7.0 μm Mono</p>	

Note: Refer to JAI's blog "[Using pixel binning to increase image quality under low light conditions](#)" on how to use the Binning function.

Pixel Format

Related Setting Items: [ImageFormatControl](#)

Selectable PixelFormat is as follows.

Color model	RGB8 (Default) , RGB10, RGB12
Monochrome model	Mono8 (Default) , Mono10, Mono12

Acquisition Control

Related Setting Items: [AcquisitionControl](#)

AcquisitionStart / AcquisitionStop

Start image acquisitions (AcquisitionStart) and end image acquisitions (AcquisitionStop).

Note: When **TriggerMode** is **On**, the camera first receives the AcquisitionStart command, the Acquisition trigger signal, and then outputs images. After the AcquisitionEnd command, no image will output when the camera receives a Acquisition trigger signal.

Change the Line Rate

When **TriggerMode** is set to **Off**, you can set the line rate using **AcquisitionLineRate**. This function can be used to match the scanning speed of the camera to the feeding speed of the object or to lengthen the accumulation time to increase sensitivity.

The minimum value that can be set is 66 Hz, and the maximum value varies depending on the settings.

Supported Operation Modes

Exposure Mode	TriggerMode	Example
Timed	Off	Control without External Triggers with the Specified Exposure Time
Off	Off	Control without External Triggers without Specifying the Exposure Time

Note: You can also save the setting, and have it applied whenever the power is subsequently turned on, but this requires additional operations. ([Step 6: Save the Settings](#))

Maximum Line Rates (Approximate)

Related Setting Items: [AcquisitionControl](#)

The maximum line rates (approximate) for various settings are shown below.

Notes:

- The followings are the maximum line rates when DeviceLinkThroughputLimitMode is Off, and Packet Size is set to 8192.
- When BinningHorizontal ([ImageFormatControl](#)) = 2 (ON), the Width value after Binning applies.

SW-2005TL-CXP

Line rate 44kHz: Sensor limitation of this model.

CXP Link Configuration	Width	Max Line Rate		
		RGB8	RGB10	RGB12
CXP-6	2048 (Full)	44kHz	44kHz	44kHz
	1536 (3/4)	44kHz	44kHz	44kHz
	1024 (1/2) or BinningHorizontal = 2 (ON)	44kHz	44kHz	44kHz
	512 (1/4)	44kHz	44kHz	44kHz
CXP-3	2048 (Full)	44kHz	44kHz	32kHz
	1536 (3/4)	44kHz	44kHz	43kHz
	1024 (1/2) or BinningHorizontal = 2 (ON)	44kHz	44kHz	44kHz
	512 (1/4)	44kHz	44kHz	44kHz

SW-2005M-CXP

Line rate 172kHz: Sensor limitation of this model.

CXP Link Configuration	Width	Max Line Rate		
		Mono8	Mono10	Mono12
CXP-6	2048 (Full)	172kHz	172kHz	172kHz
	1536 (3/4)	172kHz	172kHz	172kHz
	1024 (1/2) or BinningHorizontal = 2 (ON)	172kHz	172kHz	172kHz
	512 (1/4)	172kHz	172kHz	172kHz
CXP-3	2048 (Full)	137kHz	111kHz	94kHz
	1536 (3/4)	172kHz	146kHz	123kHz
	1024 (1/2) or BinningHorizontal = 2 (ON)	172kHz	172kHz	172kHz
	512 (1/4)	172kHz	172kHz	172kHz

Trigger Control

Related Setting Items: [AcquisitionControl](#)

The camera allows the following controls to be performed via external trigger signals.

TriggerSelector	Description
AcquisitionStart	Start image acquisition in response to the external trigger signal input. Note: You can set the number of lines between the trigger input and the time when image data is output to the host with the Image Output Delay setting.
AcquisitionEnd	Stop image acquisition in response to the external trigger signal input.
LineStart	Acquire one line in response to the external trigger input. Select this option when Exposure control is performed by an external trigger.

Notes:

- When TriggerMode is On, the camera first receives the AcquisitionStart command ([AcquisitionControl](#)), the Acquisition trigger signal, and then outputs images.
- The settings for exposure control and triggers are related to each other. Refer to "[Step 4: Configure Trigger, Exposure, and Line Rate Settings](#)" when configure the settings.

Image Output Delay

The ImageOutputDelay function allows you to set the number of lines between the trigger input and the time when image data is output to the host. This function is useful when you want to delay the time between receiving a trigger and outputting image data to the host, for example, when the object detection sensor and the line scan camera cannot be installed in the same location.

In the following example, an image of an object moving on a conveyor belt is acquired by a trigger signal from an encoder. The optical sensor and the image acquisition position of the line scan camera are 1 mm apart, and the conveyor speed is 0.1 mm per encoder cycle. In this case, the image data output is masked 10 lines after the optical sensor detects the object ($0.1 \text{ mm/edge} \times 10 \text{ lines} = 1 \text{ mm}$).

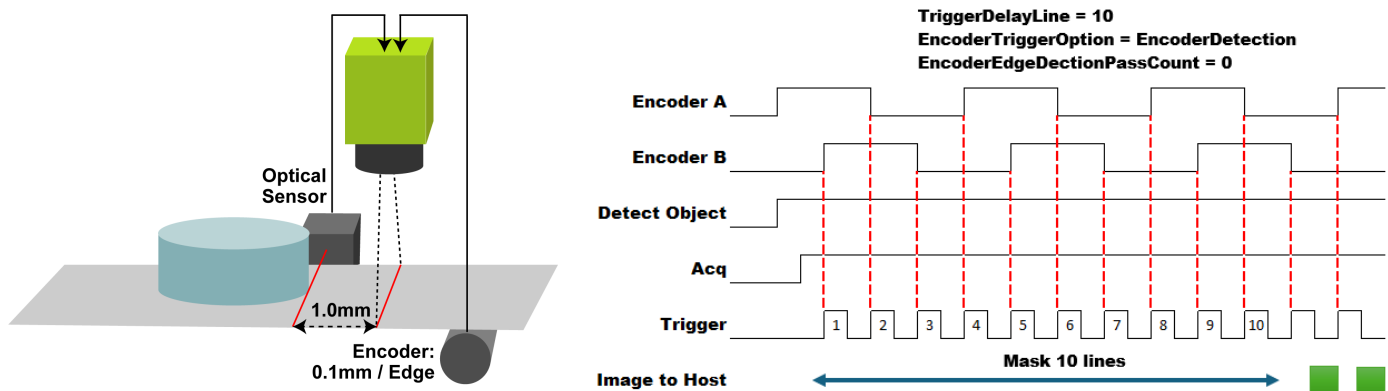

Notes:

- This function can be used not only with the encoder, but also when images are acquired using other external triggers (TriggerMode = On) or by the camera's internal trigger (TriggerMode = Off).
- When using an external trigger, set **TriggerSelector** to **AcquisitionStart**. If TriggerSelector is set to AcquisitionEnd or LineStart, this function is fixed to 0.
- For more information on the encoder, see "[Connecting Rotary Encoders](#)".

Exposure Mode

Related Setting Items: [AcquisitionControl](#)

The following exposure modes are available on the camera.

Exposure Mode	Description	Examples
Off	Exposure control is not performed (free-running operation).	Control via External Triggers without Specifying the ExposureTime
		Control without External Triggers without Specifying the Exposure Time
Timed	Mode in which control is performed using ExposureTime. Acquire images using an exposure time configured beforehand on an external trigger.	Control via External Triggers with the Specified Exposure Time
		Control without External Triggers with the Specified Exposure Time
Trigger Width	Mode in which control of the exposure time is performed using the pulse width of the trigger input signal. The exposure time will be the same as the pulse width of the trigger input signal. This allows long exposure.	Control via External Triggers with Exposure Time Controlled by the Pulse Width of the Trigger Input Signal

Note: When **ExposureMode** is set to **Timed** or **TriggerWidth**, the actual exposure time will consist of the image sensor's offset duration added to the ExposureTime setting configured on the camera or the Width of the trigger signal to the camera. For more information, see "[Actual Exposure Time](#)".

ExposureTimeMode (Color model only)

When **ExposureMode** is set to **Timed**, you can select the following Exposure Time Mode.

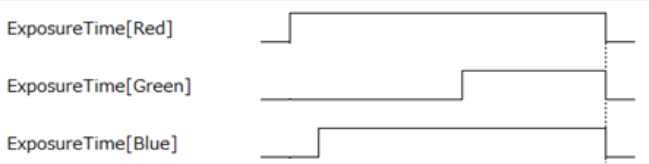
ExposureTimeMode	Description
Common (Default)	Set the common exposure time for Red, Green, and Blue (the RGB channels will have the same exposure time).
Individual	<p>Set the exposure times for Red, Green, and Blue individually. To set the exposure time individually for Red, set ExposureTimeSelector to Red, and configure the exposure time for Red in ExposureTime. Similarly, configure the exposure times individually for Green and Blue.</p> <p>Note: The actual exposure time starts with the channel with the longest exposure time and ends with the channel with the shortest exposure time, so that the exposures end at the same time (see image below).</p> 

Note: When **ExposureMode** is set other than **Timed**, **ExposureTimeMode** is fixed to **Common**.

ExposureModeOption

Specifies whether to prioritize exposure time (PrioritizeExposureTime) or line rate (PrioritizeLineRate) when controlling line rate and exposure.

- **PrioritizeExposureTime**(Default) : This option does not allow you to set a line rate shorter than the configured ExposureTime.
 - The maximum AcquisitionLineRate value is limited by the line rate value calculated from the current ExposureTime setting.
 - If you want a faster AcquisitionLineRate value, you must first decrease the ExposureTime value.

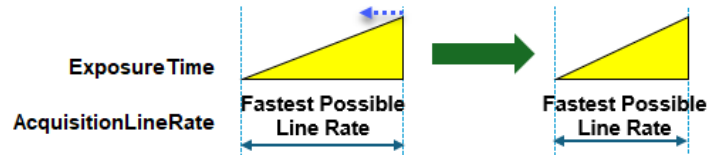

- **PrioritizeLineRate**: This option gives the line rate priority over the configured ExposureTime.
 - When AcquisitionLineRate becomes faster, if the current ExposureTime value (1) is greater than the ExposureTime value calculated from the faster AcquisitionLineRate setting (2), the ExposureTime value will be overwritten with the value (2).

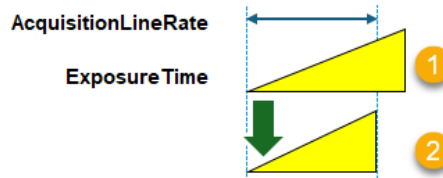

- If you want to increase the ExposureTime value further, you must first set AcquisitionLineRate to a slower value.

Actual Exposure Time

The actual exposure time will consist of the image sensor's offset duration added to the ExposureTime setting (when ExposureMode = Timed) or the Width of the trigger signal to the camera (when ExposureMode = TriggerWidth). See the table below for the exposure offset time for each camera model.

Camera Model	Exposure Offset Time
SW-2005TL-CXP	3.11 μ s
SW-2005M-CXP	1.54 μ s

The minimum ExposureTime setting is 0.11 μ s (step 0.01), and the maximum Exposure setting depends on other settings (see **Exposure Mode** on "[Specifications](#)").

Note: On this camera, when TriggerMode is set to On, there is a delay time between the external trigger input and the start of the exposure. For more information, see "[Delay Time from Trigger Input to Start of Exposure](#)".

ExposureMode = Timed

When **ExposureTime** is set to 1 μ s, the actual exposure time will be as follows.

Camera Model	ExposureTime Setting	Actual Exposure Time (ExposureTime + Offset)
SW-2005TL-CXP	1 μ s	4.11 μ s (= 1 μ s + 3.11 μ s)
SW-2005M-CXP	1 μ s	2.54 μ s (= 1 μ s + 1.54 μ s)

ExposureMode = TriggerWidth

The actual exposure time will consist of the image sensor's offset duration added to the Width of the trigger signal to the camera.

Camera Model	Exposure Time Needed	Width of the Trigger Signal to the Camera
SW-2005TL-CXP	4.11 μ s	1 μ s (= 4.11 - 3.11 μ s)
SW-2005M-CXP	2.54 μ s	1 μ s (= 2.54 - 1.54 μ s)

Note: The minimum pulse width is 0.11 μ s.

- Camera internal logic: 0.11 μ s (TriggerWidth offset 0 μ s)
- TTL High Active: 0.53 μ s (TriggerWidth offset -0.42 μ s)
- TTL Low Active: 0.17 μ s (TriggerWidth offset -0.06 μ s)

Delay Time from Trigger Input to Start of Exposure

On this camera, when TriggerMode is set to On, there is a delay time between the external trigger input and the start of the exposure. The delay time is shown below.

	ExposureMode		
	Off	Timed	TriggerWidth
Camera Internal Logic	2.00 μ s	0.13 μ s	0.91 μ s
TTL High Active	2.13 μ s	0.25 μ s	0.21 μ s
TTL Low Active	2.41 μ s	0.54 μ s	0.50 μ s
Opto High Active	2.0 μ s	0.2 μ s	0.16 μ s
Opto Low Active	2.0 μ s	0.2 μ s	0.16 μ s

GPIO (Digital Input/Output Settings)

Related Setting Items: [DigitalIOControl](#)

The camera is equipped with GPIO (general-purpose input/output) functions for generating and using combinations of triggers and other necessary signals within the camera and of signals output from the camera to the system such as those used for lighting equipment control.

These signals can be used as triggers and other necessary signals within the camera or as signals output from the camera to the system, such as those used for lighting equipment control.

Note: See "[Recommended External Input Circuit Diagram](#)" for recommended external circuit examples.

You can check the status of each digital I/O as shown in the table below with LineStatusAll.

Line Selector	Line Mode	Line Format	Line Inverter	Line Status All	Line Source
Line1 TTL Out1	Output	TTL	False / True	bit 0	User-specified
Line4 TTL In1	Input	TTL	False (Fixed)	bit 3	-
Line5 Opt In1	Input	OptoCoupled	False (Fixed)	bit 4	-
Line7 Cxp In	Input	TTL	False (Fixed)	bit 6	-
Line12 TTL Out4	Output	TTL	False / True	bit 11	User-specified
Line14 TTL In4	Input	TTL	False (Fixed)	bit 13	-

Notes:

- Line Status: "Low" signal level is indicated by **False**, and "High" signal level is indicated by **True**.
- Line Status All: The current status of the Line signal is indicated by the above bit field.
- Line Source: Selectable items are listed in "[LineSource Items](#)".

LineSource Items

This section describes each item that can be selected in **LineSource**.

LineSource	Description
AcquisitionActive	From AcquisitionStart to AcquisitionStop. See " Acquisition Control " for reference.
ExposureActive	Camera is doing the exposure. See " ExposureActive Signal " for reference.
LVAL	Image data (line) from the sensor is being read.
PulseGenerator0 ~ 3	PulseGenerator output. For more information, see the following technical note: https://www.jai.com/uploads/documents/Technical-notes/English/TNE-0005-2015XII11-000-TechNote-PulseGenerator-tips.pdf
UserOutput0 ~ 3	Allows you to toggle UserOutput's On / Off on the software. Select the User Output 0 ~ 3 you want to use from UserOutputSelector , and then set the UserOutputValue (High or Low) .
Line4 TTL In1	TTL In1
Line5 Opt In1	Opt In1
Line7 Cxp In	CXP In
Line14 TTL In4	TTL In4
Logic Block0 ~ 3	Logic Block output. See " Logic Block Control " for reference.
EncoderTrigger	Encoder output. See " Connecting Rotary Encoders " for reference.
EncoderDirection	Direction of encoder rotation. See " Rotation Direction " for reference.

ExposureActive Signal

Perform external output for the timing at which video is accumulated to the sensor. The signal is output to the DC IN / TRIG IN connector (12-pin round).

Note: ExposureActive includes the exposure offset time. For more information see "[Actual Exposure Time](#)".

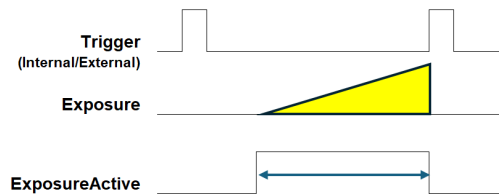

ExposureActiveSource (Color model only)

When **ExposureTimeMode** is set to **Individual** ([Exposure Mode](#)), the timing of the ExposureActive signal output will be different for each RGB channel due to the difference in RGB exposure time. Therefore, when setting **ExposureActive** for a **LineSource**, use **ExposureActiveSource** to specify which signal is output as ExposureActive (Common, Red, Green, Blue).

When **ExposureActiveSource** is set to **Common**, the channel with the longest exposure time is output as the ExposureActive signal. In the following example, the timing of the red channel is output as the ExposureActive signal.

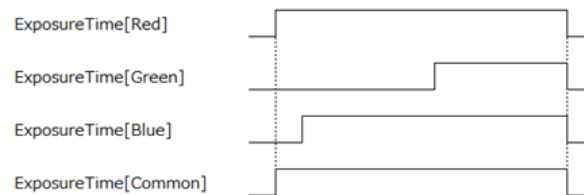

Pulse Generator

Related Setting Items: [PulseGenerator](#)



Technical Notes

Tips for using the Pulse Generator

By using this function, any signal can be generated inside the camera.

The following is an example of signal generation.

Settings

PulseGeneratorStartPoint = 2

PulseGeneratorEndPoint = 6

PulseGeneratorLength = 10

PulseGeneratorPulseWidth = 4

PulseGeneratorClearSyncMode = AsyncMode

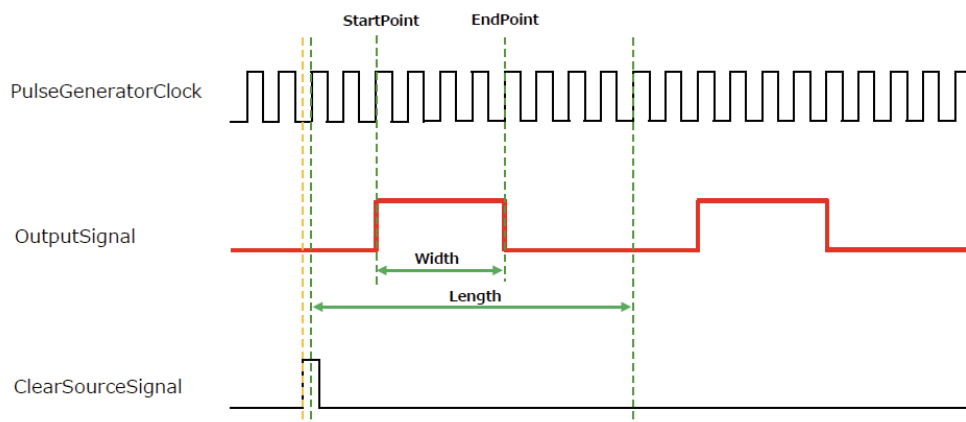

The table below shows the PulseGeneratorClearSource signals that can be set.

- ExposureActive, LVAL, PulseGenerator0-3*, UserOutput0-3, Line4 TTL In1, Line5 Opt In1, Line7 Cxp In, Line14 TTL In4, Logic Block0-3, EncoderTrigger

Note: *PulseGenerator0-3: You cannot select the same Pulse Generator that is currently selected. For example, if Pulse Generator 0 is selected, you cannot select Pulse Generator 0 as the Clear source.

Gain Control

Related Setting Items: [AnalogControl](#)

Gain control can be performed in the following two modes on this camera.

Notes:

- For details on how to configure the settings, see "[Adjust the Gain](#)."
- The Gain setting is configured in multipliers. For more information, see "[Comparison of the Decibel Display and Multiplier Display](#)."

Color Model

Master Mode (Individual Gain Mode = Off)	Individual Gain Mode = On
<p>Adjust the DigitalAll (master gain) setting first, and then adjust the DigitalRed and DigitalBlue setting values to perform fine adjustment.</p>	<p>Adjust the DigitalGreen, DigitalRed, and DigitalBlue setting values to adjust the gain.</p> <p>This mode allows a wider range of adjustment by the user when compared to Master Mode.</p>

Monochrome Model

Adjust the gain using the **DigitalAll** setting.

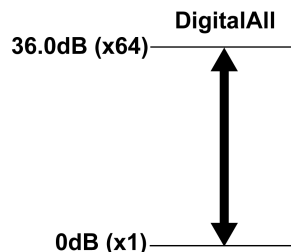

Gamma Function

Related Setting Items: [AnalogControl](#)

The Gamma function corrects the output signals from the camera beforehand (reverse correction), taking into consideration the light-emitting properties of the monitor display. As the light-emitting properties of the monitor are not linear, the entire image may be darker or the gradation in the dark areas may be less noticeable when camera outputs are displayed without processing.

The gamma function can be used to correct the camera signals with an opposite-direction curve and produce a display that is close to linear.

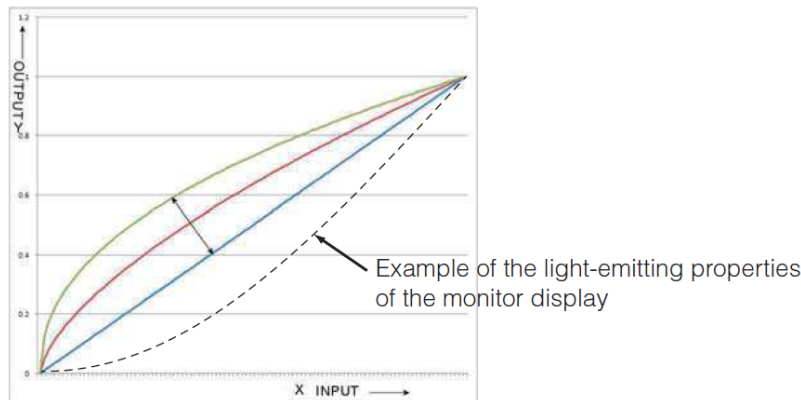

To use the Gamma function

Configure the settings as follows.

Item	Setting Value / Selectable Range	Description
Gamma	0.45, 0.5, 0.55, 0.6, 0.65, 0.75, 0.8, 0.9, 1.0	Select the gamma correction value.
JAI LUT Mode	Gamma	Use gamma.

Note: You can use the LUT function to configure a curve with more detailed points. For details, see "[LUT \(Lookup Table\)](#)".

LUT (Lookup Table)

Related Setting Items: [LUT Control](#)

The LUT function is used to generate a non-linear mapping between signal values captured on the sensor and those that are output from the camera. You can specify the output curve using 257 setting points (indexes).

To use the LUT function

Configure the settings as follows.

Item	Setting Value / Selectable Range	Description
JAI LUT Mode	LUT	Use LUT.
LUT Selector	Red, Green, Blue	Select the LUT channel to control. Note: Color model only
LUT Index	0 ~ 256	Select the LUT index to configure. Indexes represent the possible pixel values captured on the sensor, from the lowest value (Index 0) to the highest (Index 256). For example, Index 0 represents a full black pixel and Index 256 represents a full white pixel.
LUT Value	0 ~ 4095	Set the LUT output value for the selected index.

LUT values

LUT values range from 0 at the lowest to 4095 at the highest. Linear interpolation is used to calculate LUT values between the index points.

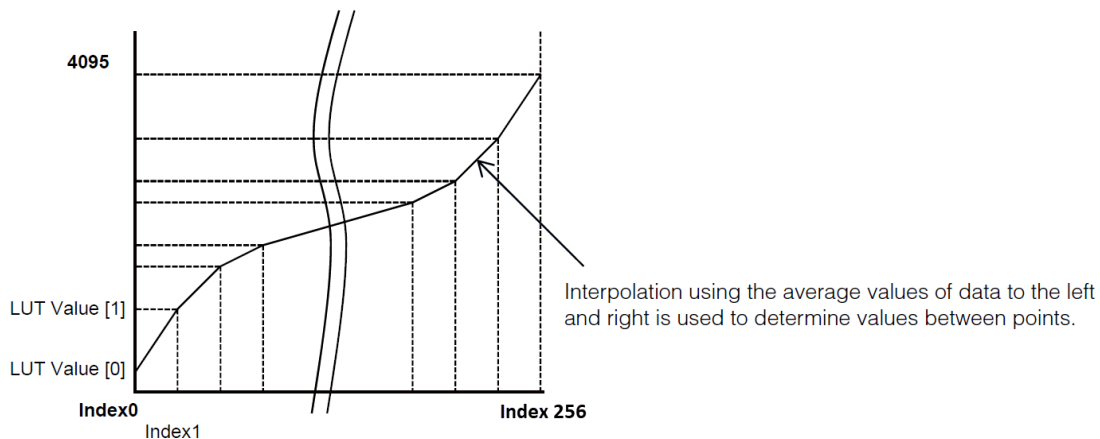

Color Space Conversion (ColorTransformationControl)

Related Setting Items: [Color Transformation Control](#)

This camera allows you to convert the standard color space (RGB) that is used to produce colors into other color spaces.

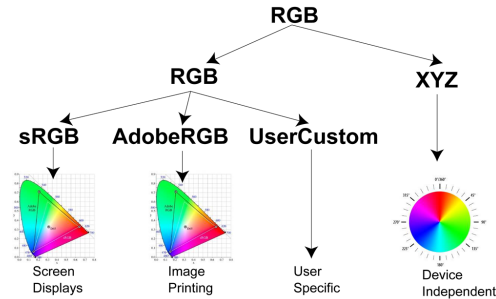

Note: This function is only supported on the color model.

How to Configure

1. Select the color space (RGB, XYZ) you want to use from **ColorTransformationMode** ([Color Transformation Control](#)).
2. When **RGB** is selected, select the details (sRGB, AdobeRGB, UserCustom) from **ColorTransformationRGBMode**.

Note: If you select other than RGB, **ColorTransformationRGBMode** is fixed to **Off**.

3. When **UserCustom** is selected,
 - i. Select the item you want to configure in **ColorMatrixValueSelector**.
 - ii. Configure the value (-2 to +2) in **ColorMatrixValue**.

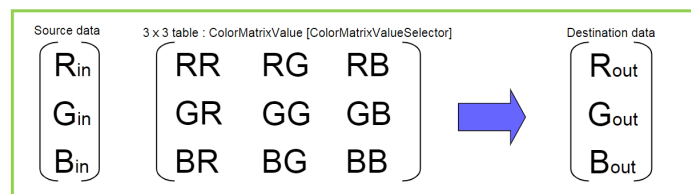

Caution: If you set the color space to XYZ, Control Tool will not display the images captured by the camera properly. To display them properly, XYZ-compatible image processing must be performed on the computer side.

Shading Correction

Related Setting Items: [Shading](#)

The Shading Correction function corrects non-uniformity (i.e., shading) in the amount of light generated by the lens and lighting equipment. This camera supports the following shading correction modes.

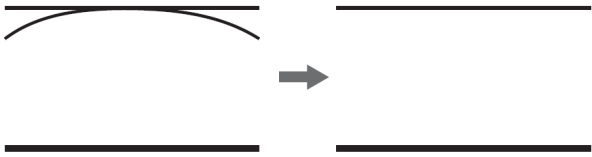
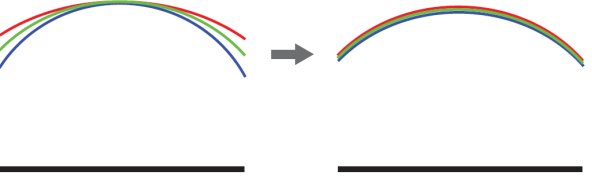
FlatShading, FlatShadingUserAreaBE	ColorShading*, ColorShadingUserArera BE*
	
<p>The highest brightness level is used as a reference, and other areas are corrected to match that brightness level. The area to calculate the correction value varies depending on the mode (see table below), but the correction value is applied to all areas (= WidthMax).</p>	<p>R-channel and B-channel properties are adjusted by using the G-channel shading properties as a reference. The area to calculate the correction value varies depending on the mode (see table below), but the correction value is applied to all areas (= WidthMax).</p>

Descriptions of Each Mode

ShadingCorrection Mode	Calculation Area	Correction Area	When the Image Is Too Bright or Dark
FlatShading	Full ROI	Full ROI	The shading correction attempt fails and an error message is displayed.
FlatShading UserAreaBE	User-specified ROI		The camera corrects the shading as close as possible to the target level.
ColorShading*	Full ROI		The shading correction attempt fails and an error message is displayed.
ColorShading UserAreaBE*	User-specified ROI		The camera corrects the shading as close as possible to the target level.

Notes:

- *Color model only
- For details on ROI, see "[ROI \(Regional Scanning Function\)](#)".
- For more information on the Shading Correction on line scan cameras, see "<https://news.jai.com/blog/lens-vignetting>".

Shading Correction Blocks

The camera makes adjustments in blocks (1 block = 2 pixels). The block Index number (ShadingDataIndex) can be used to view and change the settings per block (ShadingData). For more information, see "[How to Configure the Shading Correction Function](#)".

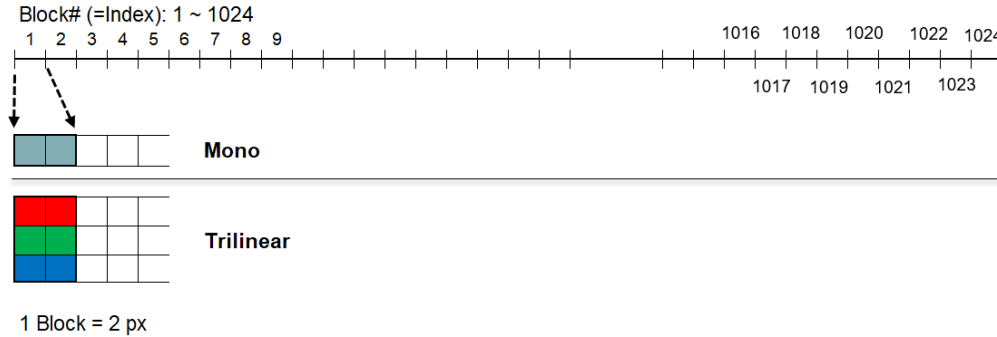

How to Configure the Shading Correction Function

This section explains how to configure the Shading Correction function.

Note: The option / selection with "*" is supported only on the color model.

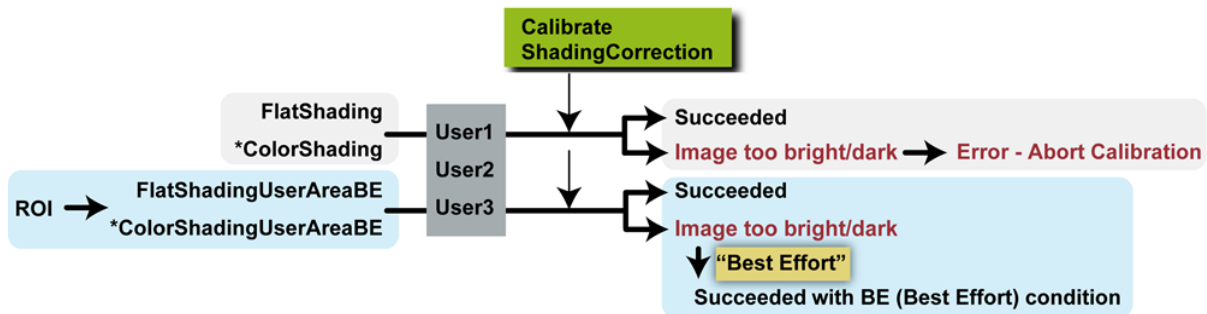

1. If you want to specify the area to calculate the correction value, configure the area with the **Width** and **OffsetX** settings [[ImageFormatControl](#)]. For more information, see [ROI \(Regional Scanning Function\)](#).
2. Select the Shading Correction Mode from **ShadingCorrectionMode**. (Flat Shading (Default), Flat Shading User Area BE, Color Shading*, Color Shading User Area BE*)

Note: For detailed information of each mode, see "[Shading Correction](#)".

3. Select the user area (User1 ~ 3) where you save the shading correction data from **ShadingMode**.
4. Display a white chart under a uniform light and execute **CalibrateShadingCorrection**.

5. Once the shading correction is successfully completed, the shading correction values are automatically saved to the area specified in ShadingMode. Also, the calibration result "**Succeeded**" is displayed in **ShadingDetectResult**.
6. If the image is too bright or too dark, the camera will operate differently depending on the selected Shading Correction Mode.
 - **FlatShading** or **ColorShading***: The shading correction attempt fails, and "**Error1 - Image was too bright**" or "**Error2 - Image was too dark**" will display in **ShadingDetectResult**.
 - **FlatShadingUserAreaBE** or **ColorShadingUserAreaBE***: The camera continues to make "best effort" adjustments and corrects the shading as close as possible to the target level. Once the correction is completed, the shading correction values are automatically saved to the area specified in ShadingMode. Also, the calibration result "**Succeeded with BE condition**" is displayed in **ShadingDetectResult**.
7. Optionally, you can view or change the setting of each correction block.
 1. Select a color channel (Red, Green, or Blue) from **ShadingDataSelector*** (color model only) and an Index number (block number) from **ShadingDataIndex**.
 2. The setting selected by ShadingDataSelector and ShadingDataIndex is displayed in **ShadingData**. To change the setting, overwrite the value (0x4000 = 1x).

Note: The set ShadingData value is rounded down to multiples of 4.

3. Execute **ShadingDataSave**. The currently set ShadingData will be overwritten and save to the area specified in **ShadingMode**.

Note: The setting is immediately reflected in the image, but is not saved until **ShadingDataSave** is executed. If **ShadingMode** is changed without executing **ShadingDataSave**, the setting will be discarded.

ShadingDetectResult

A list of correction results is shown below.

Result	ShadingCorrection Mode	Description
Idle	Any	Correction is not being performed.
Succeeded	FlatShading, ColorShading	Correction was completed successfully. The correction data calculated from the entire image area was applied to the entire image area and saved in the user area specified by ShadingMode .
	FlatShadingUserAreaBE, ColorShadingUserAreaBE	Correction was completed successfully. The correction data calculated from the specified ROI was applied to the entire image area and saved in the user area specified by ShadingMode .

Result	ShadingCorrection Mode	Description
Succeeded with BE condition	FlatShadingUserAreaBE, ColorShadingUserAreaBE	Performed correction as close as possible to the target level. Could not perform normal correction because the brightness in the specified ROI area was outside the range.
Error1 - Image was too bright	FlatShading, ColorShading	Correction failed. The image was too bright.
Error2 - Image was too dark	FlatShading, ColorShading	Correction failed. The image was too dark.
Error3 - Could not calibrated	Any	Could not perform the adjustment due to one of the following reasons: <ul style="list-style-type: none"> • The image is not being output. • TestPattern[ImageFormatControl] is set to anything other than Off. • ShadingMode is set to Off.

Pixel Sensitivity Correction (DSNU, PRNU)

Related Topic: [Correction](#)

Correct variations between the sensor's pixels.

Calibration must be performed within the camera and correction data must be created beforehand. DSNU (PixelBlackCorrect) / PRNU (PixelGainCorrect) can be reduced using that correction data.

We recommend performing calibration and creating correction data whenever the line rate setting is changed significantly.

Refer to the following topics on how to perform the calibration.

- [DSNU Correction \(Pixel Black Correct\)](#)
- [PRNU Correction \(Pixel Gain Correct\)](#)

Notes:

- Correction data is saved for DSNU (PixelBlackCorrect) / PRNU (PixelGainCorrect) according to the conditions adjusted at the factory.
- A single correction data entry can be saved on the camera for each user. When calibration is performed, the correction data is saved to the non-volatile ROM at the same time.

Chromatic Aberration Correction

Related Setting Items: [Correction](#)

This function corrects the magnification differences between the color channels which is caused by the chromatic aberration of the lens. In simpler terms when the object appears with a slightly different width on the blue, green and red channels. You can save correction data for three types of lenses.

Specify the number of pixels to delay or advance the R channel and B channel using the G channel as a reference. The correction range is -2.0 to +2.0 in steps of 0.1.

Notes:

- This function is supported only on the color model.
- Perform this function "before" mounting the camera to a system/device. If you use the [Tilt View Correction](#) function as well, perform the Tilted View function "after" the camera is mounted to a system/device. Using this approach, the camera and lens are already calibrated before the tilted view correction is applied which makes the manual tilt correction easier.
- This function assumes that the amount of deviation between the left and right is identical. If the amount of deviation between the left and right is not identical, correction will not be performed properly.

How to Configure

Follow these steps "before" mounting the camera to a system/device.

1. Select the area to apply or save the correction value in **ChromaticAberrationCorrectionMode** (Lens1 ~ 3).
2. Select how the correction is performed in **ChromaticAberrationCorrectionMethod**. Whichever option is selected, the correction is performed with the image center as the origin and the ChromaticAberrationCorrection value at both ends of the image.
 - **Simple Interpolation** (Default): Perform a two-point linear interpolation.
 - **Linear Spline Interpolation**: Performs piecewise linear interpolation using a quadratic curve formula.
 - **Custom**: Modify each correction point as desired.

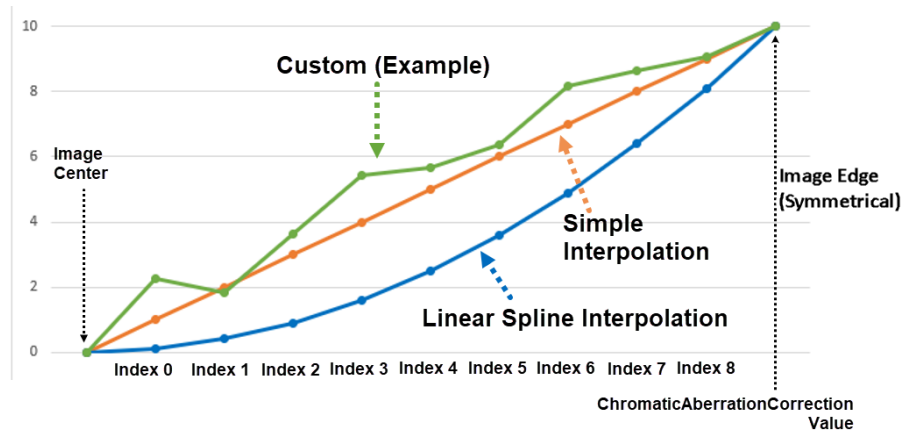

3. Configure the correction settings, which vary depending on the selected correction method.

- **Simple Interpolation:** Select **R Channel** from **ChromaticAberrationCorrectionSelector** and set the correction value in **ChromaticAberrationCorrection**.
- **Linear Spline Interpolation:** Configure the correction settings as follows.
 1. Select **R Channel** from **ChromaticAberrationCorrectionSelector**.
 2. Select the index you want to configure from **ChromaticAberrationCorrectionIndex**, and set the correction value for the selected index in **ChromaticAberrationCorrectionCoeff**.
 3. Set the amount of correction for both ends of the image in **ChromaticAberrationCorrection**.
- **Custom:** Configure the correction settings as follows.
 1. Select **R Channel** from **ChromaticAberrationCorrectionSelector**.
 2. Select the index you want to configure from **ChromaticAberrationCorrectionIndex**, and set the correction ratio for the selected index in **ChromaticAberrationCorrectionRatio**.
 3. Set the amount of correction for both ends of the image in **ChromaticAberrationCorrection**.

Caution: If the **ChromaticAberrationCorrectionMethod** is set to anything other than Custom and the **ChromaticAberrationCorrectionRatio** value is changed manually, **ChromaticAberrationCorrectionMethod** will be forced to change to **Custom**.

4. Select **B Channel** from **ChromaticAberrationCorrectionSelector**, and configure the correction settings as R Channel.
5. Execute **ChromaticAberrationCorrectionSave** to save the settings. The saved settings are for the area (Lens1 ~ 3) selected in **ChromaticAberrationCorrectionMode**.

Note: When the selected correction method is **Linear Spline Interpolation** or **Custom**, the correction value of each index will be calculated using the following formula.

- **[Linear Spline Interpolation]:** Correction value[ChromaticAberrationCorrectionIndex] = $\text{pow}(\text{ChromaticAberrationCorrectionIndex}/10, \text{ChromaticAberrationCorrectionCoeff}) \times \text{ChromaticAberrationCorrection}$
- **[Custom]:** Correction value[ChromaticAberrationCorrectionIndex] = $\text{ChromaticAberrationCorrection} \times \text{ChromaticAberrationCorrectionRatio}[\text{ChromaticAberrationCorrectionIndex}]$

Tilt View Correction

Related Setting Items: [Correction](#)

This function corrects the trapezoidal distortion that occurs when a trilinear camera is placed at an off-axis viewing angle.

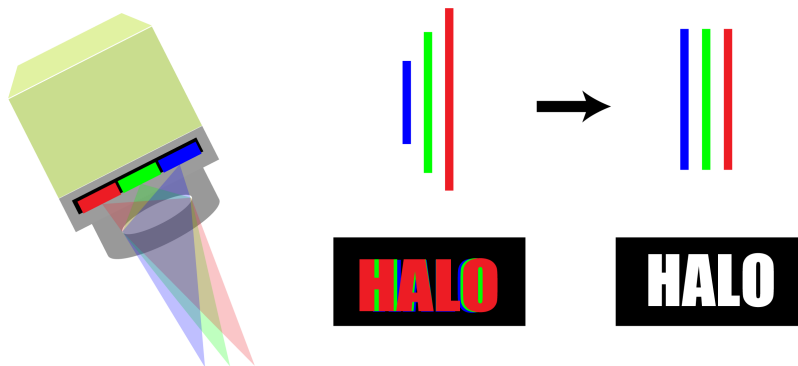

The trapezoidal distortion is caused due to the fact that the optical path from object surface to the closest color channel on the sensor is shorter than the other two color channels. As a result, color fringing, typically referred to as the “halo effect”, occurs. Use this function to make corrections to create a halo-free image.

Notes:

- This function is supported only on the color model.
- Perform this function "after" mounting the camera to a system/device. If you use the [Chromatic Aberration Correction](#) function, perform the Tilted View function "after" the camera is mounted to a system/device. By this way, if only the camera mounting position is changed without changing the lens, only the linear tilt correction needs to be considered without worrying about the quadratic color shift of chromatic aberration.

How to Configure

Follow these steps "after" mounting the camera to a system/device.

1. Select the area to apply the correction value in **TiltViewCorrectionMode** (User1 ~ 3).

Note: Default saves the correction data set at the factory. You cannot overwrite this data.

2. Select the color channel (Red or Blue) to correct from **TiltViewCorrectionSelector**.
3. Set the correction value in **TiltViewCorrection** (-1.9 ~ 1.0, step: 0.1).
4. Execute **TiltViewCorrectionSave** to save the settings. The saved settings are for the area (User1 ~ 3) selected in **TiltViewCorrectionMode**.

Noise Reduction Filter Functions

Related Setting Items: [Correction](#)

The camera has noise reduction functions. The noise reduction methods vary depending on the channel.

Three filters are available:

- **FIR Filter:** Apply the FIR (Finite Impulse Response) filter to perform smoothing.

Select the target to apply the filter from Red, Green, Blue, and set the **FIRFilterMode** to **On** (Default = Off). In FIR Filter, the coefficients of the three signals (left, center, right) can be set in the range of -2 to 2. The correction value through the FIR Filter is:

- Left pixel read value x Left pixel coefficient +
- Center pixel read value x Center pixel coefficient +
- Right pixel read value x Right pixel coefficient.

- **MEDIAN Filter:** Apply 1x3 MEDIAN filter to reduce noise.

Select the target to apply the filter from Red, Green, Blue, and set the **Median Filter Mode**. When set to **On**, this function is enabled. (Default = Off).

- **Noise Reduction:** Apply the noise filter using JAI's own algorithm.



Set the noise reduction intensity in 4 levels. Level1 = weak, Level4 = strong.

Any of the above filters can improve SNR, but it affects the sense of resolution and sensitivity. An imaging test should be performed before deciding to use this feature.

Spatial Compensation

Related Setting Items: [SpatialControl](#)

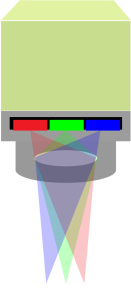
This function corrects the spatial pixel differences for the R and B lines using the G line as a reference.

	Object	ABC
	Images acquired by each channel	
	After Spatial Compensation	

On the color model, two modes are available: **Auto** and **Manual**.

Mode	Description
Auto	Using the G line as a reference, adjust and correct the R and B lines collectively. The number of pixels to be corrected for the R and B lines is automatically calculated based on the trigger interval at which the camera is operating, the amount of object movement within the sensor during a single trigger (<code>SpatialCompensationDistance</code>), and the object direction signal.
Manual	Using the G line as a reference, adjust and correct each of the R and B lines individually.

How to Compensate

First perform the spatial correction automatically, then adjust manually as needed.

1. Select **Auto** from **SpatialCompensationMode**.
2. Select the source of direction signal from **ObjectDirectionSource**. The direction signal from the rotary encoder (`EncoderDirection`), the I/O signal input of the camera, or the high/low control signal from `UserOutputValue` [[DigitalIOControl](#)] can be used as the object direction signal.
3. Specify the direction of the object's movement in **ObjectDirection** (**Foward Direction** or **Reverse Direction**).

Note: If you want to reverse the object direction, change this setting. Alternatively, you can reverse the object direction by changing the High/Low setting of the selected `ObjectDirectionSource`. For example, when **ObjectDirectionSource** is set to **UserOutputValue0** [[DigitalIOControl](#)], the object direction can be reversed by changing the **False** (Low)/**True** (High) setting of `UserOutputValue0`.

4. Set the amount of movement between triggers in subpixels in **SpatialCompensationDistance** (step: 0.01).
5. If the automatic compensation failed to correct the spatial pixel differences, adjust the R and B lines manually. To switch to the manual adjustment, select **Manual** from **SpatialCompensationMode**.
6. If the Red line needs to be adjusted, select **Red** from **SpatialCompensationSelector**, and specify the correction value (step: 0.01) in **SpatialCompensationValue** to align with the G line.
7. If the Blue line needs to be adjusted, select **Blue** from **SpatialCompensationSelector**, and specify the correction value (step: 0.01) in **SpatialCompensationValue** to align with the G line.

ObjectDirection

On this camera, the ObjectDirection setting can be used for purposes other than Spatial Compensation. In this case, it can be used not only for color models, but also for monochrome models.

For example, when the camera is paused outputting images with the [Resume Scanning \(Backward Counter\)](#) function, the camera can resume outputting images by changing the **ObjectDirection** setting to reverse the detected direction of the object.

Counter and Timer Control

Related Setting Items: [Counter and Timer Control](#)

Note: This camera supports the Counter function only.

The Counter function counts up change points in the camera's internal signals using the camera's internal counter, and reads that information from the host side. This function is useful for verifying error conditions via the count value using internal camera operations.

When a problem occurs in a system that includes this camera, comparing the values from multiple counters allows you to verify the extent of normal operability and can be useful when investigating the cause of the problem.

The following counters are available on this camera, and the functions that can be counted are fixed for each counter.

Counter Selector	Counter Event Source (Fixed)	Counter Event Activation
Counter0	Counts the number of Line Trigger instances.	Rising Edge (Fixed)
Counter1	Counts the number of Line Start instances.	Rising Edge (Fixed)
Counter2	Counts the number of Exposure Start instances.	Rising Edge (Fixed)

How to Configure

1. Select the counter you want to use from **CounterSelector**.
2. Enable the counter by selecting the event source in **CounterEventSource** (Default = Off).
3. **CounterEventActivation** displays the timing for counting for the selected counter.
4. You can reset and refresh the selected counter's counter value by executing **CounterReset** and **CounterRefresh**, respectively. The selected counter's value and status are displayed in **CounterValue** and **CounterStatus**, respectively.

Counter Occurrence Diagram (Example)

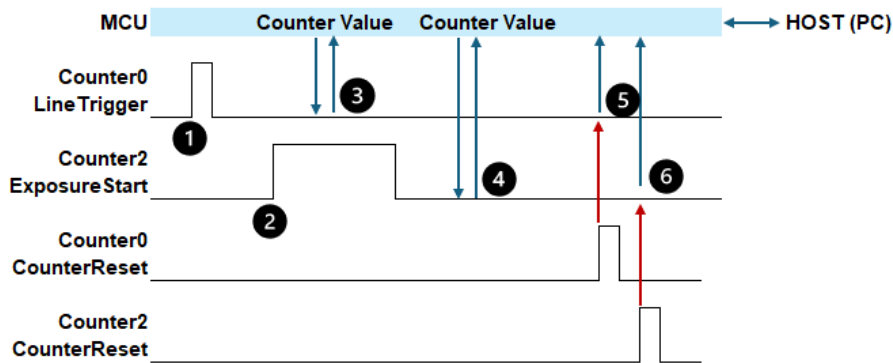

1. A LineTrigger Event occurs. Counter0 counts up.
2. An Exposure Start Event occurs. Counter 2 counts up.
3. The camera's internal MCU requests and reads the Counter0's counter value.
4. The camera's internal MCU requests and reads the Counter2's counter value.
5. Reset the Counter0's counter value to 0 by a CounterReset command or a CounterResetSource signal.
6. Reset the Counter2's counter value to 0 by a CounterReset command or a CounterResetSource signal.

Connecting Rotary Encoders

Related Setting Items: [EncoderControl](#)

Encoders are useful in line scan applications where line triggers need to be tied to motion, such as applications using conveyors with varying belt speeds.

If the object is moving at a constant speed, a fixed line rate can be set. In most cases, however, the speed of the belt speed is not always constant and must be triggered by an encoder to ensure that the speed of the object and the image acquisition are always synchronized. If the line rate and the belt speed do not match, the pixels will not be square and the image of the object will appear stretched or shrunk (see images below).

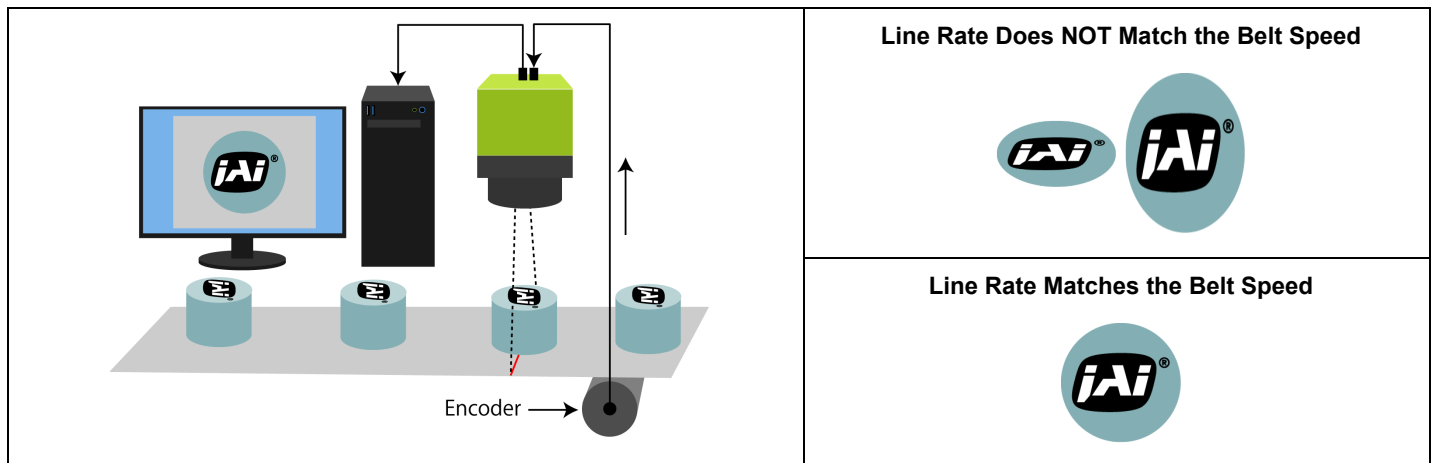

Note: JAI tests the encoder-related functions with a 2-Phase (Phase A and Phase B) incremental encoder.

How to Configure

1. Connect the two signals (Phase A and Phase B) from the rotary encoder to the camera's inputs (**EncoderSourceA** and **EncoderSourceB**). The options are: Line4 TTL In1, Line5 Opt In1, Line14 TTL In4.

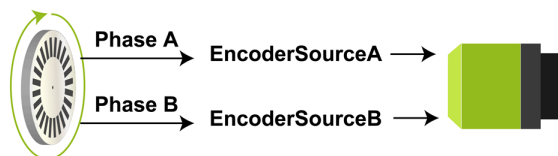

2. Select the encoder trigger method in **EncoderTriggerOption** and configure the setting.
 - **EncoderDivider** (Default) : Specify the number of triggers to generate as a ratio (65536 / EncodeDivider value). For more information, see "[EncoderDivider Trigger Option](#)".

Note: With this setting, input pulses are generated on the rising edge of the Phase A signal.

- **EncoderDetection:** Specify the number of edges to pass between each encoder trigger signal. The number of edges to pass is specified by **EncoderEdgeDetectionPassCount**. For more information, see "[EdgeDetection Trigger Option](#)".

Note: With this setting, input pulses are generated on the rising edge and falling edge of both the Phase A and B signals.

3. Specify the condition under which the camera outputs images in **EncoderOutputMode**.

- **PositionUp:** The camera outputs images at all new positions in the positive direction (when **ObjectDirection** [[SpatialControl](#)] is set to **Forward Direction**).
- **PositionDown:** The camera outputs images at all new positions in the negative direction (when **ObjectDirection** [[SpatialControl](#)] is set to **Reverse Direction**).
- **Motion (Default):** The camera outputs images at all motion increments in both directions.

Note: For more information, see "[Resume Scanning \(Backward Counter\)](#)".

4. When **EncoderOutputMode** is set to **PositionUp** or **PositionDown**, **EncoderOutputMaskedCount** displays the number of pulses generated during the reverse rotation.

- EncoderOutputMaskedCount counts up while reversing.
- EncoderOutputMaskedCount counts down when the reverse rotation is complete and the encoder rotates in the direction set by PositionUp or PositionDown. When the counter reaches 0, the camera resumes image output.

Note: For more information, see "[Resume Scanning \(Backward Counter\)](#)" and "[Rotation Direction](#)".

5. If necessary, configure the following settings.

- **EncoderFilter:** Enable the low-pass filter for the signal to prevent unintended operations due to signal noise from the rotary encoder. Specify the number of cycles from a range of 0 to 150 ns.

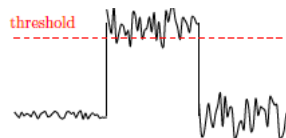

- **EncoderStrobe:** Specify the strobe length of the generated signal (10 ~ 2550 ns).
- **EncoderAveragingInterval:** When **EncoderOutputMode** is set to **EncoderDivider** and **EncoderDivider** is not set to an integer multiple of 65536, use this setting if the reliability of the interval of the signal output from the rotary encoder is low (some signal interval is extremely long or

short; the encoder's jitter is large). When this function is enabled, internal processing is performed by averaging the interval of several previous signals.

- **EncoderMaxIntervalForNonDecimationMode:** When **EncoderOutputMode** is set to **EncoderDivider** and **EncoderDivider** is not set to an integer multiple of 65536, set the maximum interval period of the output signal.

When set to 0 (Default), the trigger output period is calculated using only the encoder input period. When set to anything other than 0, the trigger output period is calculated using the encoder input period and this setting.

Note: If the time interval of the output of the rotary encoder fluctuates greatly, the output of the camera's internal trigger generated may also fluctuate greatly.

For example, if the belt is stopped for a long time and no signal is received from the encoder, **EncoderDivider** tries to generate a trigger signal calculated from the time the belt was stopped. This will result in no trigger signal being output even after the belt starts moving again.

In this case, by setting the upper limit of the Phase A interval measurement time in **EncoderAveragingInterval**, even if the encoder stops for a long time, the trigger signal can be generated with the setting configured in **EncoderMaxIntervalForNonDecimationMode**.

EncoderDivider Trigger Option

The **EncoderDivider** trigger option allows you to specify the number of triggers to generate as a ratio ($65536 / N$).

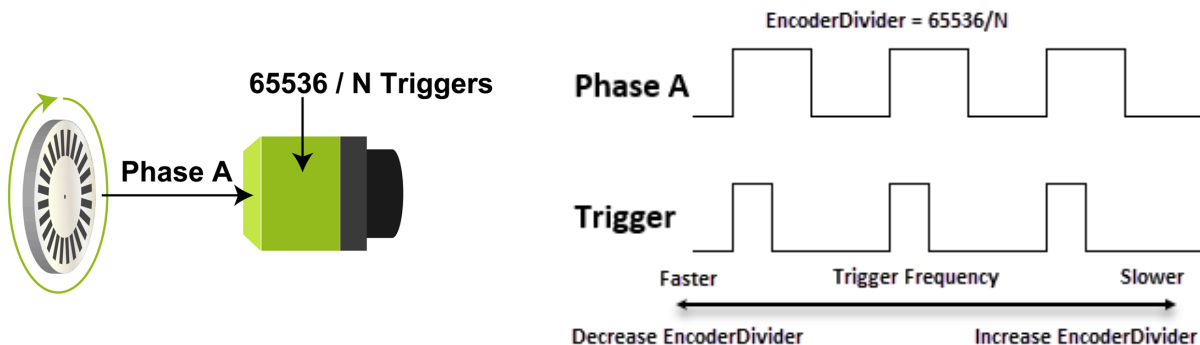

Notes:

- With this setting, input pulses are generated on the rising edge of Phase A.
- **When N is an integer multiple of 65536:** The camera's internal trigger is generated by the decimation of the output trigger of a rotary encoder.

- **When N is not an integer multiple of 65536:** Using the time interval of the output trigger of the rotary encoder, the camera's internal trigger is generated so that the set division ratio is obtained. For example, if the encoder frequency is 10kHz, but you need a line rate of 12kHz to get a proper image, then the EncoderDivider option can be used to set this 1:1.2 ratio, which will be maintained even if the encoder frequency changes.
- If the time interval of the output of the rotary encoder fluctuates greatly, the output of the camera's internal trigger generated may also fluctuate greatly. In this case, by setting **EncoderAveragingInterval**, it is possible to perform internal processing with the value obtained by averaging the time intervals of the specified number of signals.

EncoderDivider Examples

EncoderDivider Setting	Encoder Input : Encoder Trigger Ratio	Number of Triggers (Output Pulse No.)	Timing Chart
32768	1 : 2	2 (= 65536/32768) The camera generates "two" triggers per a PhaseA input pulse signal.	
65536 (Default)	1 : 1	1 (= 65536/65536) The camera generates "one" trigger per a PhaseA input pulse signal.	
131072	2 : 1	0.5 (= 65536/131072) The camera generates "one" trigger per "two" PhaseA input pulse signals.	

EdgeDetection Trigger Option

The **EdgeDetection** trigger option allows you to specify the number of edges to pass between encoder trigger signals. The number of edges to pass is specified by **EncoderEdgeDetectionPassCount**. This option is useful, for example, if you need to trigger every second or third pulse.

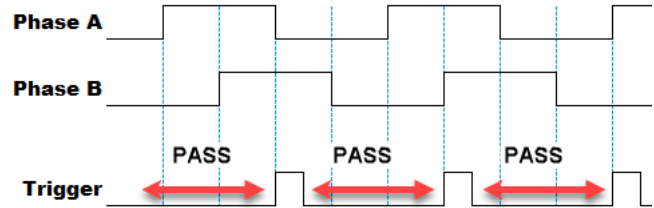
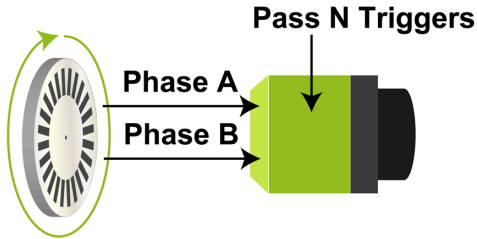

Note: With this setting, input pulses are generated on the rising and falling edge of both Phase A and B. When Phase A - Phase B are exactly 90 degrees apart, the encoder input cycle is 1/4 of Phase A's rising cycle.

EdgeDetection Examples

Edge Detection Pass Count Setting	Description	Timing Chart
0 (Default)	The camera generates "one" trigger per an input pulse signal.	
1	The camera generates "one" trigger per "two" input pulse signals.	
2	The camera generates "one" trigger per "three" input pulse signals.	

Resume Scanning (Backward Counter)

This camera can be configured to stop outputting images when the direction of movement of an object moving on a conveyor belt, etc. is reversed, and to resume outputting images when the object returns to the position where the reversal began. In order for the camera to work in this way, configure the following:

- Configure the camera so that the direction of rotation of the encoder can be determined (see "[Rotation Direction](#)")
- Set **EncoderOutputMode** to **PositionUp** or **PositionDown**.

Example

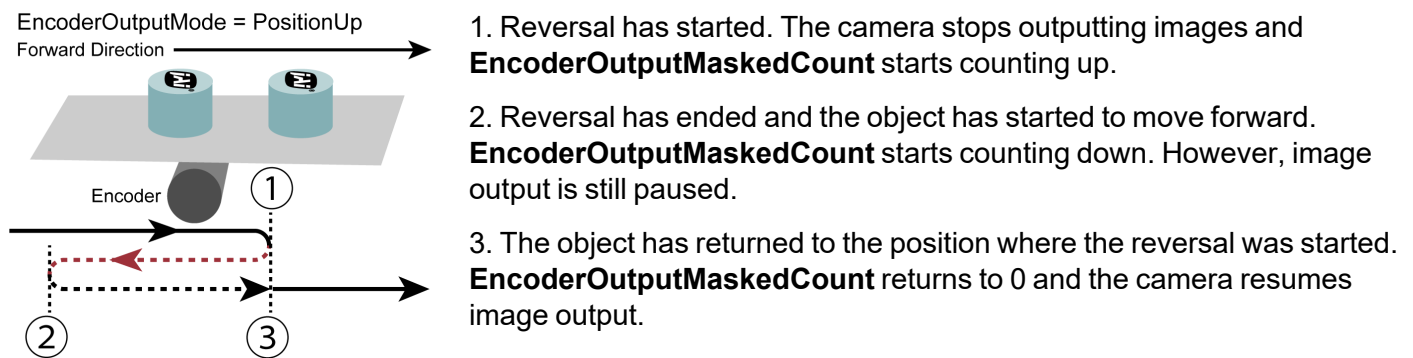

Notes:

- When **AcquisitionStart** [[AcquisitionControl](#)] is executed, **EncoderOutputMaskedCount** is reset to 0.
- If you want to output images while the object is moving in a reverse direction, change the **ObjectDirection** (Forward Direction / Reverse Direction) [[SpatialControl](#)] setting to reverse the detected direction of the object.

Rotation Direction

Incremental encoders typically have two channels (A and B), and the channels operate in a square logical pattern. In one cycle, an encoder outputs a number of pulses on each channel which is called the resolution.

Because the A and B channels are phase shifted, it is possible to determine which direction the rotation is based on which channel is leading (see below).

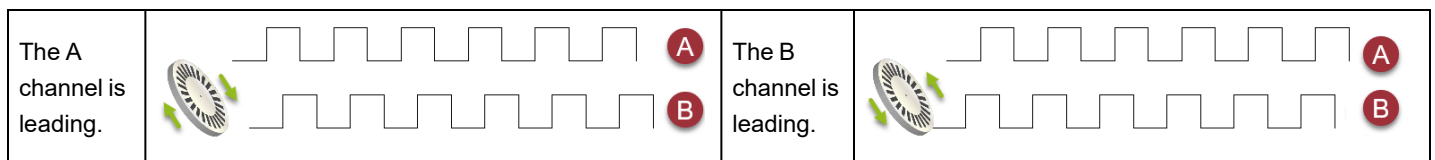

Logic Block Control

Related Topic: [Logic Block Control](#)

This camera supports the Logic Block Control function. A Logic Block is a combinational logic element that conditions various input signal sources by determining true/false and generates output signals accordingly.

This camera supports up to 4 Logic Blocks, and each block has two input sources.

Caution: On this camera, the LogicBlock function is fixed to AND, and the LogicBlock output signal is always inverted; so it acts as a NAND. For example, in the following table, the Logic Block output signal is generated when NAND is 1. If both Input signals are 1, no Logic Block output signal is generated (NAND = 0).

Input0	Input1	AND	NAND
0	0	0	1
0	1	0	1
1	0	0	1
1	1	1	0

How to Configure

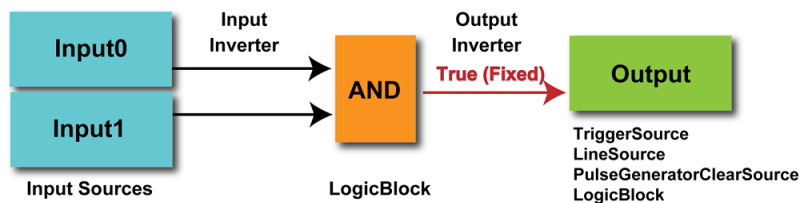

1. Set **LogicBlockSelector** to **LogicBlock0**.
2. Configure LogicBlockInput0. Set **LogicBlockInputSelector** to **0**, and select the Input Source from **LogicBlockInputSource**. If the input source is inverted, set **LogicBlockInputInverter** to **1 (True)**.
3. Configure LogicBlockInput1. Set **LogicBlockInputSelector** to **1**, and select the Input Source from **LogicBlockInputSource**. If the input source is inverted, set **LogicBlockInputInverter** to **1 (True)**.
4. Finally, configure LogicBlock0 as the output signal.

On this camera, the Logic Block can be used as the following signal source: TriggerSource [[AcquisitionControl](#)], LineSource [[DigitalIOControl](#)], PulseGeneratorClearSource [[PulseGenerator](#)], LogicBlock [[Logic Block Control](#)]

Setting List (Feature Properties)

This camera complies with GenICam. Each setting item name conforms to GenICam SFNC (Standard Features Naming Convention). (There are some JAI-specific setting items).

Each setting item is an integer type (Integer), a real type (Float), an element enumeration type (Enumeration), a character string (String), a logical type (Boolean), and a category type (Category) or a command type (Command) for executing the function.

Beginner: For beginner users.

Expert: For users with deep knowledge of camera functions.

Guru: For advanced users who make settings, including advanced features that can cause the camera to malfunction if not set correctly.

■ Selector

A Selector is used to index which instance of the feature is accessed in situations where multiple instances of a feature exist.

■ Instance Example:

Each Line-related item (LineSource, LineInverter, etc.) has LineSelector-LineX instances, which can be set or referenced as an index.

Selectors are a feature of element enumeration type (Enumeration) or an integer type (Integer). However, unlike normal configuration items, it is only used to select the instance in the following configuration item.

It does not change the behavior of the camera by changing the value of the selector. Also, the selector may have only one selectable value. In this case, use the selector function only for information purposes. In this document, it is described as SelectedFeature[Selector] according to the description method of GenICam.

In the case of Line Selector with a specific I/O line selected, the description could be as follows.

LineSource[LineSelector-LineX] = High

LineInverter[LineSelector-LineX] = False

LineMode[LineSelector-LineX] = Input

LineFormat[LineSelector-LineX] = TTL

Generally, selectors only apply to a single category of features. (Example: TriggerSelector only applies to trigger related functions.)

DeviceControl

Display/configure information related to the device.

DeviceControl Item	Setting Range	Default	Description
DeviceScanType	-	1: Line Scan	Display the device's scan type.
DeviceVendorName	-	"JAI Corporation"	Display the manufacturer name.
DeviceModelName	-	SW-2005TL-CXP SW-2005M-CXP	Display the model name.
DeviceManufacturerInfo	-	See the possibilities	Display manufacturer information.
DeviceVersion	-	-	Display the software version.
DeviceFirmwareVersion	-	-	Display the firmware version.
DeviceFpgaVersion	-	FPGA Ver. No.	Display the FPGA version.
DeviceSerialNumber	-	-	Display the device serial number.
DeviceUserID	Any	-	Set the user ID for the camera.
DeviceSFNCVersion Major	-	SFNCMajorVersion	Display the SFNC version.
DeviceSFNCVersion Minor	-	SFNCSMinorVersion	Display the SFNC version.
DeviceSFNCVersion SubMinor	-	SFNCSSubMinorVersion	Display the SFNC version.
DeviceManifestEntrySelector	1: XML1	1: XML1	Selects the manifest entry to reference. (Fixed to XML1)
DeviceManifestXML MajorVersion	-	-	Indicates the major version number of the XML file of the selected manifest entry.
DeviceManifestXML MinorVersion	-	-	Indicates the minor version number of the XML file of the selected manifest entry.
Device Manifest XML SubMinor Version	-	-	Indicates the subminor version number of the XML file of the selected manifest entry.
DeviceManifestSchema MajorVersion	-	-	Indicates the major version number of the schema file of the selected manifest entry.
DeviceManifestSchema MinorVersion	-	-	Indicates the minor version number of the schema file of the selected manifest entry.
DeviceManifest PrimaryURL	-	-	Display the PrimaryURL.
DeviceTLType	-	3: CoaXPress	Display the Transport Layer type of the device.

DeviceControl Item	Setting Range	Default	Description
DeviceTLVersionMajor	-	2	Display the major version number of the Transport Layer type.
DeviceTLVersionMinor	-	0	Display the minor version number of the Transport Layer type.
DeviceTLVersionSubMinor	-	0	Display the sub minor version number of the Transport Layer type.
DeviceMaxThroughput (Bps/sec)	390625000 ~	781250000	Maximum bandwidth of the data that can be streamed out of the device. The maximum value depends on the CxpLinkConfiguration setting. Max: [CXP6-1] 781250000 [CXP3-1] 390625000
DeviceLinkThroughput LimitMode	0: Off 1: On	0: Off	Off: No CXP bandwidth limit; Device Link Throughput Limit is disabled. On: CXP bandwidth is limited; LineRate cannot exceed the Device Link Throughput Limit value.
DeviceLinkThroughput Limit	DeviceMaxThrougout/2 ~ DeviceMaxThrougout	DeviceMaxThrougout	Enabled when DeviceLinkThroughputLimitMode = On. Limits the maximum bandwidth of the data that will be streamed out by the device.
DeviceStreamChannel Count	-	1	Display the number of supported stream channels.
DeviceStreamChannel PacketSize	256 ~ 8192	-	Specifies the stream packet size, in bytes.
Device Reset	-	-	Reset the device.
Device Registers Endianness	-	1: Big	Endianness of the registers of the device.
Device Temperature (°C)	- 55 ~ 125	-	Display the internal temperature (°C) of the camera.
Timestamp	0 ~ 64-bit max (ns)	-	Display the timestamp value (ns). Resets to 0 when the signed maximum 64-bit value is exceeded.
TimestampReset	-	-	Forcibly sets the timestamp's count value to 0.
TimestampLatch	-	-	Sets the timestamp's count value to TimestampLatchValue.
TimestampLatchValue	0 ~ 64bit max (ns)	-	Returns the latched value of the timestamp counter.

DeviceControl Item	Setting Range	Default	Description
UserDefinedValueSelector	0: Value1 1: Value2 2: Value3 3: Value4 4: Value5	0: Value1	32bit data x 5 can be set and saved.
UserDefinedValue	-2147483648 ~ 2147483647	0	Read and set the value for the 32-bit data (Value 1 to Value5) selected in UserDefinedValueSelector.

TransportLayerControl

Display information on transport layer control.

Transport Layer Control Item	Setting Range	Default	Description
PayloadSize (bytes)	48 ~ 67109240	-	Display the payload size. (unit: bytes) Default: SW-16000TL-CXP4A-M95: 49152 SW-16000M-CXP4A-M95:16384
DeviceTapGeometry	-	0: Geometry_ 1X_1Y (Fixed)	The method of transferring images from the device at one time (TAP configuration).
CoaXPress			
CxpLinkConfigurationPreferred	CXP-6	-	Displays the link structure that allows the camera to operate in default mode.
CxpLinkConfiguration	0x38: CXP-3 (3.125 Gbps) 0x48: CXP-6 (6.25Gbps) (Default)		Set the CoaXPress Link Configuration.
JAICxpLinkConfigurationPreferred	0x00010038: CXP3_X1 0x00010048: CXP6_X1 (Default)		Custom command to change and save the CxpLinkConfigurationPreferred configuration value.
CxpConnectionSelector	-	-	Select the CoaXPress physical connection you want to control.
CxpConnectionTestMode	0: Off 1: On	0: Off	0: Normal Mode 1: Sends a test packet to each connection that is connected.
CxpConnectionTestErrorCount	-	-	Reports the current connection error count for the test packet.
CxpConnectionTestPacketCount	-	-	Reports the current count of test packets.

Transport Layer Control Item	Setting Range	Default	Description
CxpStreamPacketSize	256 ~ 8192, step 4	-	Set the CXP stream packet size. When the stream transfer conditions are changed by changing ConnectionConfig, PixelFormat, or Width, this setting item is recalculated and updated to be equal.
CxpVersionUsed	2: CXP1.1 3: CXP2.0	-	Display the current CXP version. When the frame grabber supports CXP2.0, "3: CXP2.0" is displayed.

ImageFormatControl

Configure image format settings.

Image Format Control Item	Setting Range	Default	Description
SensorWidth	SW-2005M-CXP: 2048 SW-2005TL-CXP: 2048		Display the maximum image width.
WidthMax	SW-2005M-CXP: 2048 (1024) SW-2005TL-CXP: 2048 (1024) (): BinningHorizontal = 2		Display the maximum image width.
Width	128 (64)* ~ [WidthMax - OffsetX], Step: 8 (8) (): BinningHorizontal = 2	WidthMax	Set the image width.
Height	-	1 (Fixed)	Display the image height.
OffsetX	0 ~ [WidthMax - Width], Step: 8 (8) (): BinningHorizontal = 2	0	Set the horizontal offset.
BinningHorizontalMode	0: Sum 1: Average	0: Sum	Set the processing method for horizontal binning.
BinningHorizontal	1: Off 2: On	1: Off	Set the number of pixels in the horizontal direction for which to perform binning.
ReverseX	0: Off 1: On	0: Off	Reverse pixels horizontally.

Image Format Control Item	Setting Range	Default	Description
PixelFormat	Color Model: 0x02180014: RGB8 (Default) 0x02300018: RGB10 0x0230001A: RGB12 Monochrome Model: 0x01080001: Mono8 (Default) 0x01100003: Mono10 0x01100005: Mono12		Set the Pixel Format.
PixelSize	Color Model: RGB8: Bpp24 (Default) RGB10: Bpp48 RGB12: Bpp48 Monochrome Model: Mono8: Bpp8 (Default) Mono10: Bpp16 Mono12: Bpp16		Display the total pixel size of the output image in bits.
Test Pattern	0: Off 1: White 2: GreyPattern1 (Ramp) 3: GreyPattern2 (Stripe) 4: ColorBar (Color model only)	0: Off	Select the type of test pattern that is generated by the device as image source.

AcquisitionControl

Related Topic: [Acquisition Control](#)

Configure image capture settings.

Acquisition Control Item	Setting Range	Default	Description									
AcquisitionMode	2: Continuous (Fixed)		Display the image capture mode.									
AcquisitionStart	-	-	Start image capture.									
AcquisitionStop	-	-	Stop image capture.									
AcquisitionLineRate (Hz)	66 Hz ~ (step: 0.01)	-	Set the AcquisitionLineRate (Hz). The maximum value varies depending on the PixelFormat and ROI settings.									
Related Topic: Change the Line Rate			<table border="1"> <thead> <tr> <th>Model</th> <th>PixelFormat</th> <th>Max (Full ROI)</th> </tr> </thead> <tbody> <tr> <td>SW-2005TL-CXP</td> <td>RGB8</td> <td>44kHz</td> </tr> <tr> <td>SW-2005M-CXP</td> <td>Mono8</td> <td>172kHz</td> </tr> </tbody> </table>	Model	PixelFormat	Max (Full ROI)	SW-2005TL-CXP	RGB8	44kHz	SW-2005M-CXP	Mono8	172kHz
	Model	PixelFormat	Max (Full ROI)									
	SW-2005TL-CXP	RGB8	44kHz									
SW-2005M-CXP	Mono8	172kHz										

Acquisition Control Item	Setting Range	Default	Description
TriggerSelector Related Topic: Trigger Control	0: AcquisitionStart 1: AcquisitionEnd 2: LineStart		Select the trigger operation.
TriggerMode	0: Off 1: On	0: Off	Enables/Disables the Trigger mode.
TriggerSoftware	-	-	Execute a software trigger.
TriggerSource	7-10: PulseGenerator0-3 11-14: UserOutput0-3 19: Software 23: Line4 TTL In1 (Default) 24: Line5 Opt In1 26: Line7 Cxp In 33: Line14 TTL In4 36-39: Logic Block0-3 40: EncoderTrigger		Select the trigger signal source.
TriggerActivation	0: RisingEdge (Default) 1: FalingEdge 2: LevelHigh 3: LevelLow		Select the polarity of the trigger signal (i.e., location of signal at which trigger is applied).
ImageOutputDelay Related Topic: Image Output Delay	0 ~ 65535 (1Line / Step)	0	Set the number of lines between the AcquisitionStart trigger input and the time when image data is output to the host. Note: Only enabled when TriggerSelector = AcquisitionStart when TriggerMode is On.
Exposure Mode Related Topic: Exposure Mode	0: Off 1: Timed (Default) 2: Trigger Width		Select the exposure mode.
ExposureTimeMode	0: Common (Default) 1: Individual*		When set to Individual, ExposureTime can be adjusted for RGB individually. Note: *Individual: Color model only

Acquisition Control Item	Setting Range	Default	Description
ExposureTimeSelector	0: Common (Default) 1: Red* 2: Green* 3: Blue*		Selects which exposure time is controlled by the ExposureTime feature. Note: *Red, Green, Blue: Color model only
Exposure Time (μs) Related Topic: Actual Exposure Time	0.11 μs ~ (step: 0.01)	-	Set the exposure time for the channel selected in ExposureTimeSelector. The maximum time vary depending on the settings. For the exposure time information on each setting, see . Offset Time Duration SW-2005TL-CXP: 3.09 μs SW-2005M-CXP: 1.51 μs
ExposureModeOption Related Topic: Exposure Mode	0: PrioritizeExposureTime (Default) 1: PrioritizeLineRate		Specifies whether to prioritize exposure time (PrioritizeExposureTime) or line rate (PrioritizeLineRate) when controlling line rate and exposure.

DigitalIOControl

Related Topic: [GPIO \(Digital Input/Output Settings\)](#)

Configure settings for digital input/output.

Digital IO Control Item	Setting Range	Default	Description
LineSelector	20: Line1 TTL Out1 (Default) 23: Line4 TTL In1 24: Line5 Opt In1 26: Line7 Cxp In 31: Line12 TTL Out4 33: Line14 TTL In4		Select the input/ output to configure.
LineMode	0: Input 1: Output		Display the input/ output status (whether it is input or output).
Line Inverter	0: False 1: True	False	Enable/disable polarity inversion for the selected input signal or output signal.
Line Status	0: False (Low) (Default) 1: True (High)		Display the status of the input signal or output signal (True: High, False: Low).

Digital IO Control Item	Setting Range	Default	Description
LineStatusAll	bit0: Line1 (Default) bit1 ~ 2: Unused bit3: Line4 bit4: Line5 bit5: Unused bit6: Line7 bit10: Unused bit11: Line12 bit13: Line14 bit14 ~ 15: Unused		Display the input/output signal status. <div style="background-color: #f0f0f0; padding: 5px;"> Note: Unused = (Fixed) to 0 </div>
LineSource <div style="background-color: #f0f0f0; padding: 5px;"> Related Topic: LineSource Items </div>	1: AcquisitionActive 4: ExposureActive 6: LVAL 7: PulseGenerator0 8: PulseGenerator1 9: PulseGenerator2 10: PulseGenerator3 11: UserOutput0 12: UserOutput1 13: UserOutput2 14: UserOutput3 23: Line4 TTL In1 (Default) 24: Line5 Opt In1 26: Line7 Cxp In 33: Line14 TTL In4 36: Logic Block0 37: Logic Block1 38: Logic Block2 39: Logic Block3 40: EncoderTrigger 41: Encoder Direction		Select the line source signal for the item selected in Line Selector. The following is fixed to "-": 23: Line4 TTL In1 24: Line5 Opt In1 26: Line7 Cxp In
Line Format	2: TTL 5: OptoCoupled		Display the current I/F type. Default: 24: Line5 Opt In1 = OptoCoupled Other = TTL

Digital IO Control Item	Setting Range	Default	Description
OptInFilter	0 ~ 1000000 (ns)	0	Select the period for filtering mask of the Opt-In signal.
User Output Selector	0: User Output 0 (Default) 1: User Output 1 2: User Output 2 3: User Output 3		Set the user output signal.
User Output Value	0: False (Low) (Default) 1: True (High)		Set the User Output value selected in User Output Selector.
ExposureActiveSource	0: Common (Default) 1: Red 2: Green 3: Blue		Select the channel for the ExposureActive signal when LineSource is set to ExposureActive. When set to Common , the channel with the longest exposure time is output as the ExposureActive signal. Note: Color model only

Related Topic:
[ExposureActive
Signal](#)

PulseGenerator

Related Topic: [Pulse Generator](#)

Configure pulse generator settings.

Pulse Generators Item	Setting Range	Default	Description
ClockPre-scaler	1~ 4096	1	Set the division value for the prescaler (12-bit) using the pixel clock as the base clock.
PulseGeneratorClock (MHz)	$\text{PulseGeneratorClock} = 100 / \text{ClockPreScaler}$	100	Set the clock used for the pulse generator. This value is calculated based on the Clock Pre-Scaler value.
Pulse Generator Selector	0: PulseGenerator0 (Default) 1: PulseGenerator1 2: PulseGenerator2 3: PulseGenerator3		Select the pulse generator.
PulseGeneratorLength Value	1 ~ 1048575	30000	Set the maximum count up value using clock value.
PulseGeneratorLength (ms)	$\text{PulseGeneratorLength} = 1 / \text{PulseGeneratorClock} * \text{PulseGeneratorLengthValue}$	0.3	Set the maximum count up value using ms. This value is calculated based on the Pulse Generator Length value. The setting range varies depending on the Clock Pre-Scaler value.
PulseGeneratorFrequency (Hz)	$\text{PulseGeneratorFrequency} = 1\text{sec} / \text{PulseGeneratorLength}$	3333.3333	Set the maximum count up value using frequency. This value is calculated based on the Pulse Generator Length value.
PulseGeneratorStartPoint Value	0 ~ 1048574	0	Set the start point for the High interval using clock value. When the counter reaches this value, the output becomes 1.
PulseGeneratorStartPoint (ms)	$\text{PulseGeneratorStartPoint} = 1 / \text{PulseGeneratorClock} * \text{PulseGeneratorStartPointValue}$	0	Set the start point for the High interval using ms. When the counter reaches this value, the output becomes 1. The setting range varies depending on the Clock Pre-Scaler value.
PulseGeneratorEndPoint Value	1 ~ 1048575	15000	Set the start point for the Low interval using clock value. When the counter reaches this value, the output becomes 0.
PulseGeneratorEndPoint (ms)	$\text{PulseGeneratorEndPoint} = 1 / \text{PulseGeneratorClock} * \text{PulseGeneratorEndPointValue}$	0.15	Set the start point for the Low interval using ms. When the counter reaches this value, the output becomes 0. The setting range varies depending on the Clock Pre-Scaler value.

Pulse Generators Item	Setting Range	Default	Description
PulseGeneratorPulseWidth (ms)	$\text{PulseGeneratorPulseWidth} = \frac{1}{\text{PulseGeneratorClock}} * (\text{PulseGeneratorEndPointValue} - \text{PulseGeneratorStartPointValue})$	0.15	Display High interval width for the pulse in ms. This is a calculation of the time between the Start Point and End Point. The setting range varies depending on the Clock Pre-Scaler value.
PulseGeneratorRepeat Count	0 ~ 255	0	Set the repeat count for the counter. When this is set to 0, the counter will be free-running with limitless repeating.
PulseGeneratorClear Activation	0: Off 1: LevelHigh 2: LevelLow 3: RisingEdge 4: FallingEdge	0: Off	Set the clear signal condition for the count clear input of the pulse generator.
PulseGeneratorClear Source	4: ExposureActive 6: LVAL 7-10: PulseGenerator0-3 11-14: UserOutput0-3 23: Line4 TTL In1 (Default) 24: Line5 Opt In1 26: Line7 Cxp In 33: Line14 TTL In4 36-39: Logic Block0-3 40: EncoderTrigger		Select the count clear input signal source.
PulseGeneratorClear SyncMode	0: Async Mode (Default) 1: Sync Mode		Select the sync mode for the count clear input signal.

AnalogControl

Configure analog control settings.

Note: Items with "*" are only supported on the color model.

Analog Control Item	Setting Range	Default	Description											
IndividualGainMode*	0: Off 1: On	0: Off	In IndividualGainMode, RGB can be configured individually for the entire gain adjustment range of the sensor.											
			Note: For the color model, this setting is enabled only when IndividualGainMode is set to On .											
InGainBypassMode	0: Off 1: On	0: Off	When On , disable the camera's internal fixed gain (= InGain) and only enable the user-set gain.											
GainSelector*	0: Digital All (Individual Gain Mode = OFF Only) 1: Digital Red 2: Digital Green (Individual Gain Mode = ON Only) 3: Digital Blue		Select the gain to configure. Note: When IndividualGaiMode is set to Off, DigitalGreen's Gain value is fixed to "1".											
Gain	-	1.00	Set the gain value for the gain item selected with the GainSelector setting (Unit: times, step:0.01). <table border="1"> <thead> <tr> <th></th> <th>Individual Mode</th> <th>Range</th> </tr> </thead> <tbody> <tr> <td rowspan="2">Color model</td> <td>OFF</td> <td>DigitalAll: 1.00 ~ 32.00 DigitalRed / Blue: 0.40 ~ 4.00</td> </tr> <tr> <td>ON</td> <td>1.00 ~ 64.00</td> </tr> <tr> <td>Monochrome model</td> <td>NA</td> <td>1.00 ~ 64.00</td> </tr> </tbody> </table>		Individual Mode	Range	Color model	OFF	DigitalAll: 1.00 ~ 32.00 DigitalRed / Blue: 0.40 ~ 4.00	ON	1.00 ~ 64.00	Monochrome model	NA	1.00 ~ 64.00
	Individual Mode	Range												
Color model	OFF	DigitalAll: 1.00 ~ 32.00 DigitalRed / Blue: 0.40 ~ 4.00												
	ON	1.00 ~ 64.00												
Monochrome model	NA	1.00 ~ 64.00												
GainAuto	0: Off (Default) 1: Once		Enable/disable gain auto adjustment. Once automatically changes to Off when the signal level converges once. Note: GainAuto can only be use when IndividualGainMode = Off.											
GainAutoWidth	-	-	The same setting range as Width [ImageFormatControl].											

Analog Control Item	Setting Range	Default	Description
GainAutoOffsetX	-	-	The same setting range as OffsetX [ImageFormatControl].
AGCReference	30 ~ 95 %	50	Set the target level for GainAuto in percentage.
AGCOnceStatus	0: Idle (Default) 1: Processing 3: Succeeded 7: Error3 - Timeout 8: Error4 - could not processing		Display the GainAuto status. For more information, see " Adjust the Gain ".
BlackLevelSelector	0: All (Default) 1: Red* 2: Blue*		Select the black level to configure.
BlackLevel	All:-133 ~ 255 (Default: 0) Red*:-64 ~ 64 (Default: 0) Blue*:-64 ~ 64 (Default: 0)		Set the black level value.
BalanceWhiteAuto*	0: Off (Default) 1: Once 2: Once User Area BE 3: Preset 5000K 4: Preset 6500K 5: Preset7500K		Enable/disable auto white balance. When using a Color Temperature option (Preset 500K, Preset6500K, or Preset7500K) , IndividualGainMode [AnalogControl] must be set to Off .
BalanceWhiteAutoWidth*	-	-	The same setting range as Width [ImageFormatControl] .
BalanceWhiteAutoOffsetX*	-	0	The same setting range as OffsetX [ImageFormatControl].
BalanceWhiteAutoResult*	-	-	Display the BalanceWhiteAuto result. For more information, see " Adjust the White Balance ". 0: Idle (Default) 1: Processing 3: Succeeded 4: Succeeded with BE condition 5: Error1 - G image was too bright 6: Error2 - G image was too dark 7: Error3 - Timeout 8: Error4 - Target level was too high 9: Error5 - Target level was too low

Analog Control Item	Setting Range	Default	Description
Gamma Related Topic: Gamma Function	0.45 (Default), 0.5, 0.55, 0.6, 0.65, 0.75, 0.8, 0.9, 1.0		Set the gamma value.
LUT Mode	0: Off (Default) 1: Gamma 2: LUT		Select the JAI LUT mode.

LUT Control

Related Topic: [LUT \(Lookup Table\)](#)

Configure LUT settings.

LUT Control Item	Setting Range	Default	Description
LUT Selector	Red Green Blue	Red	Select the LUT channel to control. Note: Color model only
LUT Index	0 ~ 256	0	Set the LUT index table number.
LUT Value	0 ~ 4095		Set the LUT index table number.

Color Transformation Control

Related Topic: [Color Space Conversion \(ColorTransformationControl\)](#)

Configure LUT settings.

Note: Color model only

Color Transformation Control Item	Setting Range	Default	Description																				
ColorTransformationMode	0: RGB (Default) 2: XYZ		Set the output image format.																				
ColorTransformation RGBMode	0: Off (Default) 1: sRGB 2: AdobeRGB 3: UserCustom		Set the detailed mode when RGB is selected for the color space.																				
ColorMatrixValueSelector	0: ColorMatrixR-R (Default) 1: ColorMatrixR-G 2: ColorMatrixR-B 3: ColorMatrixG-R 4: ColorMatrixG-G 5: ColorMatrixG-B 6: ColorMatrixB-R 7: ColorMatrixB-G 8: ColorMatrixB-B		Select the ColorMatrix setting component.																				
ColorMatrixValue	-2.0 ~ 2.0	-	Set the Color Matrix value. <table border="1"> <thead> <tr> <th>ColorMatrixValueSelector</th> <th>Default Value</th> </tr> </thead> <tbody> <tr> <td>ColorMatrixR-R</td> <td>1.0</td> </tr> <tr> <td>ColorMatrixR-G</td> <td>0</td> </tr> <tr> <td>ColorMatrixR-B</td> <td>0</td> </tr> <tr> <td>ColorMatrixG-R</td> <td>0</td> </tr> <tr> <td>ColorMatrixG-G</td> <td>1.0</td> </tr> <tr> <td>ColorMatrixG-B</td> <td>0</td> </tr> <tr> <td>ColorMatrixB-R</td> <td>0</td> </tr> <tr> <td>ColorMatrixB-G</td> <td>0</td> </tr> <tr> <td>ColorMatrixB-B</td> <td>1.0</td> </tr> </tbody> </table>	ColorMatrixValueSelector	Default Value	ColorMatrixR-R	1.0	ColorMatrixR-G	0	ColorMatrixR-B	0	ColorMatrixG-R	0	ColorMatrixG-G	1.0	ColorMatrixG-B	0	ColorMatrixB-R	0	ColorMatrixB-G	0	ColorMatrixB-B	1.0
ColorMatrixValueSelector	Default Value																						
ColorMatrixR-R	1.0																						
ColorMatrixR-G	0																						
ColorMatrixR-B	0																						
ColorMatrixG-R	0																						
ColorMatrixG-G	1.0																						
ColorMatrixG-B	0																						
ColorMatrixB-R	0																						
ColorMatrixB-G	0																						
ColorMatrixB-B	1.0																						

Shading

Related Topic: [Shading Correction](#)

Configure settings for other JAI functions.

Shading Control Item	Setting Range	Default	Description
ShadingCorrectionMode	0: Flat Shading (Default) 1: Flat Shading User Area BE 2: Color Shading* 3: Color Shading User Area BE* Note: *Color model only		Select the shading correction method.
ShadingMode	0: Off (Default) 2: User1 3: User2 4: User3		Set the area to which to save shading correction data. When this is set to Off , shading correction is disabled.
CalibrateShadingCorrection	-	-	Execute shading correction.
ShadingCalibrationResult	0: Idle 3: Succeeded 4: Succeeded with BE condition 5: Error1 - Image was too bright 6: Error2 - Image was too dark 7: Error3 - Could not calibrated		Display the shading correction results. For more information, see " Shading Correction ".
ShadingDataSelector	0: Red (Default) 1: Green 2: Blue Note: Color model only		Selects which the color of shading data (color) to set.
ShadingDataIndex	1 ~ 1024	1	Selects which the index of shading data to set.
ShadingData	0 ~ 0x1FFFF*	0x4000 (= x1)	Configure and display ShadingData selected by ShadingDataSelector and ShadingDataIndex. The set value is rounded down to multiples of 4. Note: *Upper limit when configured manually; values higher than this may be displayed when CalibrateShadingCorrection is performed.
ShadingDataSave	-	-	Overwrites the currently set ShadingData and saves it in one of the User1~User3 areas based on the ShadingMode value.

Correction

Correct variations due to sensors and lenses.

Note: Items with "*" are only supported on the color model.

Correction Control Item	Setting Range	Default	Description
PixelBlackCorrectionMode Related Topic: DSNU Correction (Pixel Black Correct)	0: Off 1: Default (Default) 2: User1 3: User2 4: User3		(DSNU) Select under which setting to store / load the correction values. Note: Default saves the correction data set at the factory. You cannot overwrite this data.
CalibratePixelBlackCorrection	-	-	(DSNU) Generate black level correction data automatically from the captured image. Please follow the instructions on " DSNU Correction (Pixel Black Correct) ". Caution: When PixelBlackCorrectionMode is set to Off or Default, or test pattern is being output instead of an image, this command cannot be executed. In this case, " Error3 - Could not calibrated " is displayed on PixelBlackCalibrationResult .
PixelBlackCalibrationResult	-	-	(DSNU) Display the results of Calibrate Pixel Black Correction execution. 0: Idle (Default) 3: Succeeded 5: Error1 - Image was too bright 6: Error2 - Image was too dark 7: Error3 - Could not calibrated
PixelGainCorrectionMode Related Topic: PRNU Correction (Pixel Gain Correct)	0: Off 1: Default (Default) 2: User1 3: User2 4: User3 5: SelectedROI		(PRNU) Select under which setting to store / load the correction values. For detailed steps, see " PRNU Correction (Pixel Gain Correct) ". User1 ~ 3: Performs PRNU on the entire area (full ROI), and stores correction values in the selected area. SelectedROI: Performs PRNU on the area specified by the ROI settings (Width and OffsetX values [ImageFormatControl]), and stores correction values in UserArea. Note: Default saves the correction data set at the factory. You cannot overwrite this data.

Correction Control Item	Setting Range	Default	Description
CalibratePixelGainCorrection	-	-	(PRNU) Generate gain correction data automatically from the captured image. Caution: When PixelGainCorrectionMode is set to Off or Default , or a test pattern is being output instead of an image, this command cannot be executed. In this case, " Error3 - Could not calibrated " is displayed on PixelGainCalibrationResult .
PixelGainCalibrationResult	-	-	(PRNU) Display the results of Calibrate Pixel Gain Correction execution. For more information on the results, see " PRNU Correction (Pixel Gain Correct) ". 0: Idle (Default) 3: Succeeded 4: Succeeded with BE condition 7: Error3 - Could not calibrated
ChromaticAberrationCorrectionMode*	0: Off (Default) 1: Lens1 2: Lens2 3: Lens3		Selects the area to load or save the Chromatic Aberration Correction values. Related Topic: Chromatic Aberration Correction
ChromaticAberrationCorrectionMethod*	0: Simple Interpolation (Default) 1: Linear Spline Interpolation 2: Custom		Selects the Chromatic Aberration Correction method. Simple Interpolation: Perform a two-point linear interpolation. Linear Spline Interpolation: Performs piecewise linear interpolation using a quadratic curve formula. Custom: Modify each correction point as desired.
ChromaticAberrationCorrectionSelector*	0: R channel (Default) 2: B channel		Selects the color of the Chromatic Aberration Correction values.
ChromaticAberrationCorrectionIndex*	0 ~ 8	1	Selects the Index to refer the Chromatic Aberration Correction Ratio values.
ChromaticAberrationCorrectionRatio*	-1.000 ~ 1.000; step 0.001	0.125	Sets the Chromatic Aberration Correction Ratio values.
ChromaticAberrationCorrection*	-2.0 ~ 2.0; step 0.1	0	Sets the value of the Chromatic Aberration Correction.
ChromaticAberrationCorrectionCoeff*	1 ~ 10; step 0.1	2	Sets the coefficient value of the Chromatic Aberration Correction for Linear Spline Interpolation.
ChromaticAberrationCorrectionSave*	-	-	Save the related value of the Chromatic Aberration Correction features.

Correction Control Item	Setting Range	Default	Description
TiltViewCorrectionMode* Related Topic: Tilt View Correction	0: Off (Default) 1: User1 2: User2 3: User3		Selects the area to load or save the Tilt View Correction values. Note: Default saves the correction data set at the factory. You cannot overwrite this data.
TiltViewCorrectionSelector*	0: R channel (Default) 2: B channel		Selects the color of the Tilt View Correction.
TiltViewCorrection*	- 1.0 ~ 1.0; step 0.1	0	Sets the value of the Tilt View Correction.
TiltViewCorrectionSave*	-	-	Save the value of the TiltViewCorrection.
FIRFilterSelector* Related Topic: Noise Reduction Filter Functions	0:Red (Default) 1:Green 2:Blue		Select the target to apply FIR Filter from Red, Green, Blue.
FIRFilterMode	0: Off 1: On	0: Off	Enable / Disable FIR Filter.
FIRFilterLeftRatio	-2 ~ 2	0	Set the coefficient of the left pixel when FIR Filter is applied.
FIRFilterCenterRatio	-2 ~ 2	1	Set the coefficient of the center pixel when FIR Filter is applied.
FIRFilterRightRatio	-2 ~ 2	0	Set the coefficient of the right pixel when FIR Filter is applied.
MEDIANFilterSelector*	0: Red (Default) 1: Green 2: Blue		Select the target to apply Median Filter from Red, Green, Blue.
MEDIANFilterMode	0: Off 1: On	0: Off	Enable / Disable MEDIAN Filter.
NoiseReduction	0: Off (Default) 1: Level1 2: Level2 3: Level3 4: Level4		Set the noise reduction intensity in 4 levels. Level1 = weak, Level4 = strong

SpatialControl

Corrects the spatial pixel differences for the R, G, and B lines.

Related Topic: [Spatial Compensation](#)

Note: Items with "*" are also supported on the monochrome model.

Spatial Control Item	Setting Range	Default	Description
SpatialCompensationMode	0: Manual 1: Auto (Default)		Set the spatial compensation mode.
SpatialCompensationSelector	0: Red (Default) 2: Blue		Set the channel. Note: SpatialCompensationMode = Manual Only
SpatialCompensationValue (pixels)	-1.0 ~ 1.0; step: 0.01	0	Set the compensation value for each channel. Note: SpatialCompensationMode = Manual Only
ObjectDirection*	0: Forward Direction (Default) 1: Reverse Direction		Set the direction of moving objects.
ObjectDirectionSource*	11-14: UserOutput0-3 (Default = UserOutput0) 23: Line4 TTL In1 24: Line5 Opt In1 26: Line7 Cxp In 33: Line14 TTL In4 39: EncoderDirection		Select the input to use for obtaining the movement direction information for the object.
SpatialCompensationDistance (pixels)	-1.0 ~ 1.0; step: 0.01	0	Set the amount of movement in pixels of the imaging subject within the sensor during a single trigger. Note: SpatialCompensationMode = Auto Only

Counter and Timer Control

Related Topic: [Counter and Timer Control](#)

Configure counter settings. (This camera only supports counter functions.)

Counter and Timer Control Item	Setting Range	Default	Description
CounterSelector	0: Counter0 (Default) 1: Counter1 2: Counter2		Select the counter.
CounterEventSource	0: Off (Default) 1: Line Trigger (Counter0 Only) 2: Line Start (Counter1 Only) 3: Exposure Start (Counter2 Only)		Select the counter event signal for which to read the count value.
CounterEventActivation	1: RisingEdge (Default) 2: FallingEdge		Display the timing at which to count.
CounterResetSource	0: Software (Default) 23: Line4 TTL In1 24: Line5 Opt In1 26: Line7 Cxp In 33: Line14 TTL In4		Select the signals that will be the source to reset the Counter. When set to Software, the counter value is reset by the CounterReset command. If set to a value other than Software, the counter is reset by the line input signal (GPIO).
CounterResetActivation	1: RisingEdge (Default) 2: FallingEdge 3: LevelHigh 4: LevelLow		Set the counter reset timing when CounterResetSource is set to a value other than Software.
CounterReset	-	-	Reset the counter.
Counter Value	0 ~ 32bit max	0	Display the count value.
CounterStatus	0: CounterIdle (Default) (CounterEventSource = Off) 1: CounterTriggerWait 2: CounterActive (CounterEventSource = other than Off) 3: CounterCompleted 4: CounterOverflow (CounterEventSource = other than Off and CouterValue = Max)		Display the counter status.

EncoderControl

Related Topic: [Connecting Rotary Encoders](#)

Configure settings for encoder control.

Encoder Control Item	Setting Range	Default	Description
EncoderSourceA EncoderSourceB	0: Off (Default) 23: Line4 TTL In1 24: Line5 Opt In1 33: Line14 TTL In4		Select where to input the signal from the rotary encoder.
EncoderTriggerOption	0: EncoderDivider (Default) 1: EdgeDetection		Select the encoder triggering method. EncoderDivider specifies the number of triggers to generate as a ratio (65536 / EncoderDivider value). EncoderDetection specifies the number of edges to pass between encoder trigger signals.
EncoderDivider	1~ 32bit max	65536	When EncoderDivider is selected for EncoderTriggerOption , set the number of triggers to be generated as a ratio 65536 / (set value).
EncoderEdgeDetectionPassCount	0 ~ 65535	0	When EdgeDetection is selected for EncoderTriggerOption , set how many edges to pass between encoder trigger signals.
EncoderOutputMode	1: PositionUp 2: PositionDown 5: Motion (Default)		Specify the condition under which a valid encoder output signal is generated. PositionUp: Outputs images at all new positions in the positive direction (when ObjectDirection [SpatialControl] is set to Forward Direction). When the direction of encoder rotation is reversed, the camera stops outputting images until EncoderOutputMaskedCount returns 0, while output pulses continue to be generated. PositionDown: Outputs images at all new positions in the negative direction (when ObjectDirection [SpatialControl] is set to Forward Direction). When the direction of encoder rotation is reversed, the camera stops outputting images until EncoderOutputMaskedCount returns 0, while output pulses continue to be generated. Motion: Outputs images at all motion increments in both directions.

Encoder Control Item	Setting Range	Default	Description
EncoderOutputMaskedCount	0 ~ 32bit max	0	<p>Display the number of pulses during the reverse rotation after the AcquisitionStart command when EncoderOutputMode is set to PositionUp or PositionDown.</p> <p>The counter counts up during the reverse rotation. The counter counts down when rotation returns to the direction set by EncoderOutputMode.</p>
EncoderFilter (ns)	0 ~ 150, step: 10	0	Apply a low-pass filter to prevent noise on the signal from the rotary encoder and stabilize the signal for the specified number of cycles.
EncoderStrobe (ns)	10 ~ 2550, step: 10	100	Set the strobe length of the Trigger signal generated from the rotary encoder by the number of cycles.
EncoderAveragingInterval	0: none (Default) 1: 2 pulses 2: 4 pulses 3: 8 pulses 4: 16 pulses 5: 32 pulses		<p>When EncoderOutputMode is set to EncoderDivider and EncoderDivider is not set to an integer multiple of 65536, use this setting if the reliability of the interval of the signal output from the rotary encoder is low (some signal interval is extremely long or short; the encoder's jitter is large).</p> <p>When this function is enabled, internal processing is performed by averaging the interval of several previous signals.</p>
EncoderMaxIntervalForNonDecimationMode (s)	0 ~ 60	0	<p>When EncoderOutputMode is set to EncoderDivider and EncoderDivider is not set to an integer multiple of 65536, set the maximum interval period of the output signal. This setting item is disabled when EncoderDivider is set to an integer multiple of 65536.</p> <p>0: The trigger output period is calculated using the encoder input period only. 1 ~ 60: The trigger output period is calculated using the encoder input period and this setting.</p>

Logic Block Control

Related Topic: [Logic Block Control](#)

Configure Logic Block settings.

Logic Block Control Item	Setting Range	Default	Description
Logic Block Selector	0: Logic Block 0 (Default) 1: Logic Block 1 2: Logic Block 2 3: Logic Block 3		Specifies the Logic Block to configure.
Logic Block Function	AND (Fixed)		Selects the combinational logic Function of the Logic Block to configure.
Logic Block Input Selector	0 ~ 1	0	Selects the Logic Block's input to configure.
Logic Block Input Source	4: ExposureActive 6: LVAL 7: PulseGenerator0 8: PulseGenerator1 9: PulseGenerator2 10: PulseGenerator3 11: UserOutput0 12: UserOutput1 13: UserOutput2 14: UserOutput3 23: Line4 TTL In1 (Default) 24: Line5 Opt In1 26: Line7 Cxp In 33: Line14 TTL In4 36: Logic Block0 37: Logic Block1 38: Logic Block2 39: Logic Block3 40: Encoder Trigger 41: Encoder Direction		Selects the source signal for the input into the Logic Block.
Logic Block Input Inverter	0: False 1: True	0: False	Selects if the selected Logic Block Input source signal is inverted.
Logic Block Output Inverter	True (Fixed)		Selects if the selected Logic Block Output signal is inverted.

UserSetControl

Related Topic: [Step 6: Save the Settings](#)

Load factory default settings or save/load user settings for camera settings.

User Set Control Item	Setting Range	Default	Description
User Set Selector	Default User Set1 ~ 3	0: Default (factory default values)	Select the user settings.
User Set Load	-	-	Load user settings.
User Set Save	-	-	Save the current setting values as user settings.

Miscellaneous

Troubleshooting

Check the following before requesting help. If the problem persists, contact your local JAI distributor.

■ Power Supply and Connections

Issue: The POWER/TRIG LED remains lit amber and does not turn green, even after power is supplied to the camera.

Cause and Solution: Camera initialization may not be complete. Check the 12-pin cable connection.

■ Image Display

Issue: Gradation in dark areas is not noticeable.

Cause and Solution: Use the gamma function to correct the display. As the light-emitting properties of the monitor are not linear, the entire image may be darker or the gradation in the dark areas may be less noticeable when camera outputs are displayed without processing. Using the gamma function performs correction to produce a display that is close to linear. For details, see [Gamma Function](#).

■ Settings and Operations

Issue: Settings cannot be saved to user memory.

Cause and Solution: You cannot save to user memory while images are being captured by the camera. Stop image capture before performing the save operation.

Issue: I want to restore the factory default settings.

Cause and Solution: Load **Default** under User Set Selector in the Feature Properties tab to restore the factory default settings.

Specifications

Item	Specifications			
Image Sensor	SW-2005TL-CXP: Trilinear CMOS line scan image sensor SW-2005M-CXP: Monochrome CMOS line scan image sensor			
		Effective Pixels	Pixel Size	
	SW-2005TL-CXP	2048 x 3 (R, G, B)	7.0 μ m x 7.0 μ m	
	SW-2005M-CXP	2048 x 1	7.0 μ m x 7.0 μ m	
Synchronization	Internal			
Communication Interface	CoaxPress v2.0/v1.1 (CXP-6) LinkConfiguration: CXP-6_X1, CXP-3_X1			
Line Rate	Model	PixelFormat	Min	Max
	SW-2005TL-CXP	RGB8	66Hz	44kHz
		RGB10	66Hz	44kHz
		RGB12	66Hz	44kHz
	SW-2005M-CXP	Mono8	66Hz	172kHz
		Mono10	66Hz	172kHz
		Mono12	66Hz	172kHz
Note: *When taking a trigger signal from the outside, there is no limitation on the minimum value				
Dark SN	Model	Channel	SN (Typ)	Note
	SW-2005TL-CXP	R	51.5 dB	Dark Level@10bit (Individual Gain = Off); DSNU and PRNU Correction = On; GainAll/GainRed*/GainBlue* = 0dB (*Color model only)
		G	52.5 dB	
		B	51.0 dB	
SW-2005M-CXP	-	58.0 dB		
Bright SN	Model	Channel	SN (Typ)	Note
	SW-2005TL-CXP	R	32.0 dB	890LBS@10bit (Individual Gain = Off); DSNU and PRNU Correction = On; GainAll/GainRed*/GainBlue* = 0dB (*Color model only)
		G	32.0 dB	
		B	31.5 dB	
	SW-2005M-CXP	-	35.5 dB	

Item	Specifications			
Digital Image Output Format	ROI (Horizontal) / Binning	Width: 128(64) ~ 2048(1024) pixels, 8 (8) pixels/step		
		OffsetX: 0 ~ 2048(1024) pixels, 8 (8) pixels/step		
		(): BinningHorizontal = 2		
	ROI (Vertical)	1 (Fixed)		
Pixel Format	SW-2005TL-CXP: RGB8 (Default) , RGB10, RGB12			
	SW-2005M-CXP: Mono8(Default) , Mono10, Mono12			
Exposure Mode	Model	ExposureMode	ExposureTime (step 0.01μs, Including Exposure Offset Time)	
	SW-2005TL-CXP	Off	Line Period - 0.4 μ s	
		Timed (Trigger Off)	3.22 μ s ~ 15.148 ms	
		Timed (Trigger On)	3.22 μ s ~ 15.148 ms	
		TriggerWidth*	Trigger Width + 3.11 μ s (3.22 μ s ~ 1s)	
	SW-2005M-CXP	Off	Line Period - 0.4 μ s	
		Timed (Trigger Off)	1.65 μ s ~ 15.148 ms	
		Timed (Trigger On)	1.65 μ s ~ 15.148 ms	
TriggerWidth*		Trigger Width +1 .54 μ s (1.65 μ s ~ 1s)		
<p>*LineStart trigger Only</p> <p>When TriggerMode is set to On, there is a delay time between the external trigger input and the start of the exposure. For more information, see "Delay Time from Trigger Input to Start of Exposure".</p>				
ExposureTimeMode: Common, Individual (Individual = Color model only)				
Trigger Selector	Acquisition: AcquisitionStart / AcquisitionEnd Exposure: LineStart			
Trigger Input Signals (12-pin)	TTL In x2, Opto In, Software, CXP In, Pulse Generator x4, Logic Block x 4, Encoder Trigger Positive / negative logic switchable. Minimum trigger width: 0.11 μ s and more			
Gain Adjustment	Model	Mode	Manual Adjustment	
	SW-2005TL-CXP	Master Mode	DigitalAll: 0 ~ 30dB DigitalRed/DigitalBlue: -7.96 ~ +12dB	
		Individual Gain Mode	DigitalGreen, DigitalRed, DigitalBlue: 0 ~ 36dB	
	SW-2005M-CXP	-	DigitalAll: 0 ~ 36dB	
GainAuto: Off, Once, Continuous (Continuous = Master Mode Only)				
Black Level Adjustment	Model			
	SW-2005TL-CXP	DigitalAll, DigitalRed, DigitalBlue: -133 ~ +255 (LSB@12bit)		
	SW-2005M-CXP	DigitalAll: -133 ~ +255 (LSB@12bit)		

Item	Specifications		
White Balance	BalanceWhiteAuto: Off, Once, Once User Area BE, Preset5000K, Preset6500K, Preset7500K		
Test Pattern	White, GreyPattern1(Ramp), GreyPattern2 (Stripe), ColorBar* (*Color model only)		
Image Processing	<p>Pixel Sensitivity Correction: Pixel Correction (DSNU, PRNU)</p> <p>Shading Correction: FlatShading, FlatShadingUserAreaBE, ColorShading, ColorShadingUserAreaBE</p> <p>LUT: Off : y =1.0, ON: 257 points can be set.</p> <p>Gamma: 0.45, 0.5, 0.55, 0.6, 0.65, 0.75, 0.8, 0.9, 1.0 (9 steps available)</p> <p>Noise Reduction Filter (MEDIAN, FIR, NoiseReduction*)</p>		
Power Supply (12-pin Connector)	<table border="1"> <tr> <td data-bbox="531 621 711 680">Input Range</td> <td data-bbox="711 621 1510 680">DC + 10.8V ~ + 26.4V</td> </tr> </table>	Input Range	DC + 10.8V ~ + 26.4V
	Input Range	DC + 10.8V ~ + 26.4V	
<table border="1"> <tr> <td data-bbox="531 680 711 861" rowspan="2">Consumption</td> <td data-bbox="711 680 1510 770">SW-2005TL-CXP: 4.6W Typical (Default Setting/25°C Environment) @DC +12V, 5.1W (Max)</td> </tr> <tr> <td data-bbox="711 770 1510 861">SW-2005M-CXP: 4.5W Typical (Default Setting/25°C Environment) @DC +12V, 4.9W (Max)</td> </tr> </table>	Consumption	SW-2005TL-CXP: 4.6W Typical (Default Setting/25°C Environment) @DC +12V, 5.1W (Max)	SW-2005M-CXP: 4.5W Typical (Default Setting/25°C Environment) @DC +12V, 4.9W (Max)
Consumption		SW-2005TL-CXP: 4.6W Typical (Default Setting/25°C Environment) @DC +12V, 5.1W (Max)	
	SW-2005M-CXP: 4.5W Typical (Default Setting/25°C Environment) @DC +12V, 4.9W (Max)		
Power Supply (PoCXP)	<table border="1"> <tr> <td data-bbox="531 882 711 940">Input Range</td> <td data-bbox="711 882 1510 940">DC +18.5V ~ 26V</td> </tr> </table>	Input Range	DC +18.5V ~ 26V
	Input Range	DC +18.5V ~ 26V	
<table border="1"> <tr> <td data-bbox="531 940 711 1121" rowspan="2">Consumption</td> <td data-bbox="711 940 1510 1031">SW-2005TL-CXP: 4.6W Typical (Default Setting/25°C Environment), 5.1W (Max)</td> </tr> <tr> <td data-bbox="711 1031 1510 1121">SW-2005M-CXP: 4.5W Typical (Default Setting/25°C Environment), 4.9W (Max)</td> </tr> </table>	Consumption	SW-2005TL-CXP: 4.6W Typical (Default Setting/25°C Environment), 5.1W (Max)	SW-2005M-CXP: 4.5W Typical (Default Setting/25°C Environment), 4.9W (Max)
Consumption		SW-2005TL-CXP: 4.6W Typical (Default Setting/25°C Environment), 5.1W (Max)	
	SW-2005M-CXP: 4.5W Typical (Default Setting/25°C Environment), 4.9W (Max)		
Flange back	17.526mm (in air), tolerance: 0 mm to ~ 0.05 mm		
Verified Performance Temperature/Humidity	<p>0°C ~ +45°C (20 to 80%, non-condensing)</p> <p>Note: It may change depending on the installation environment. Please refer to the Caution in this section.</p>		
Storage Temperature/Humidity	-25°C ~ +60°C (20 to 80%, non-condensing)		
Vibration Resistance	10G (20 Hz~ 200 Hz X-Y-Z direction)		
Shock Resistance	80G		
Regulations	CE (EN55032:2015/A11:2020, EN55035:2017(CISPR35:2016)), FCC Part 15 Subpart B, RoHS/WEEE, KC		
Dimensions	44mm × 44mm × 54mm (WHD; excluding lens mount protrusions and connectors)		
Weight	SW-2005TL-CXP: 154g; SW-2005M-CXP: 153g		

Notes:

- Design and specifications are subject to change without notice.
- Approximately 30 minutes of warm-up are required to achieve these specifications.

Caution: About the verified performance temperature

Make sure the following temperature conditions are met when operating the unit.

- The camera's internal temperature should not exceed 60 °C during operation.

If the above temperature conditions are exceeded, take measures to dissipate heat according to your installation environment and conditions.

Spectral Response (SW-2005TL-CXP)

SW-2005 Sensitivity

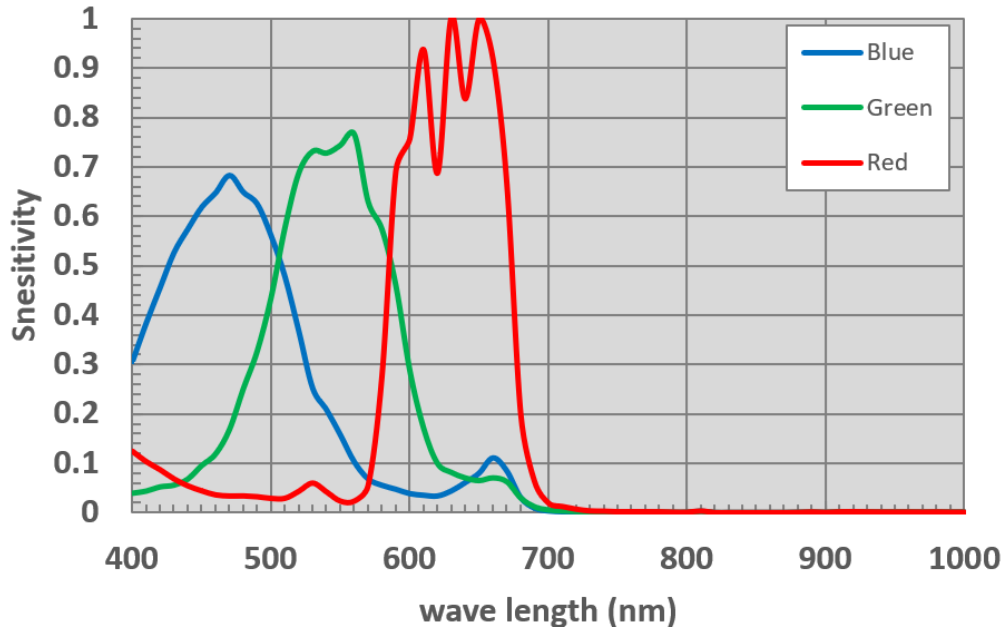

Spectral Response (SW-2005M-CXP)

SW-2005 Sensitivity

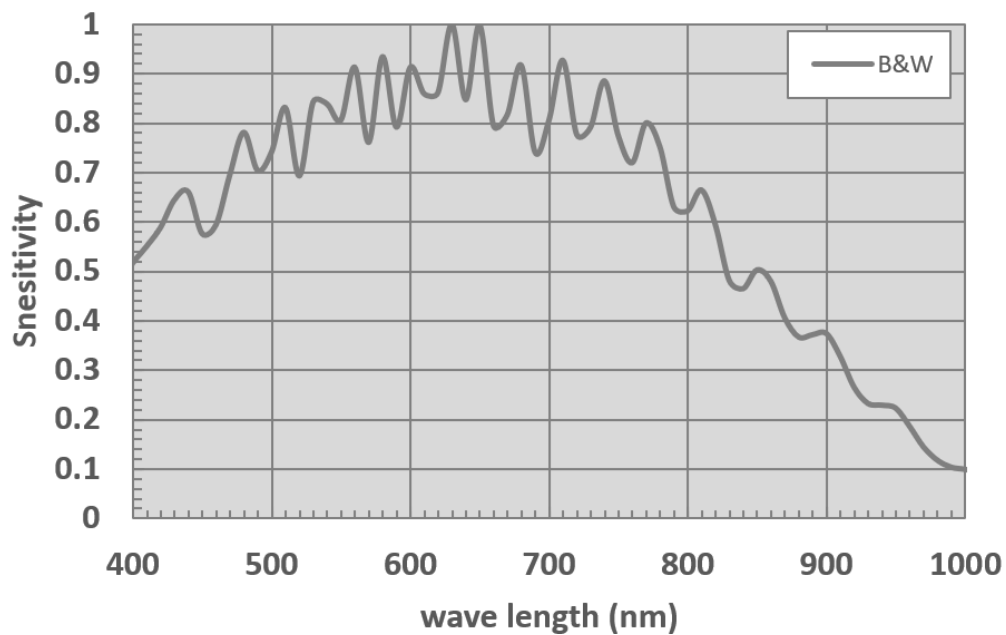

Dimensions

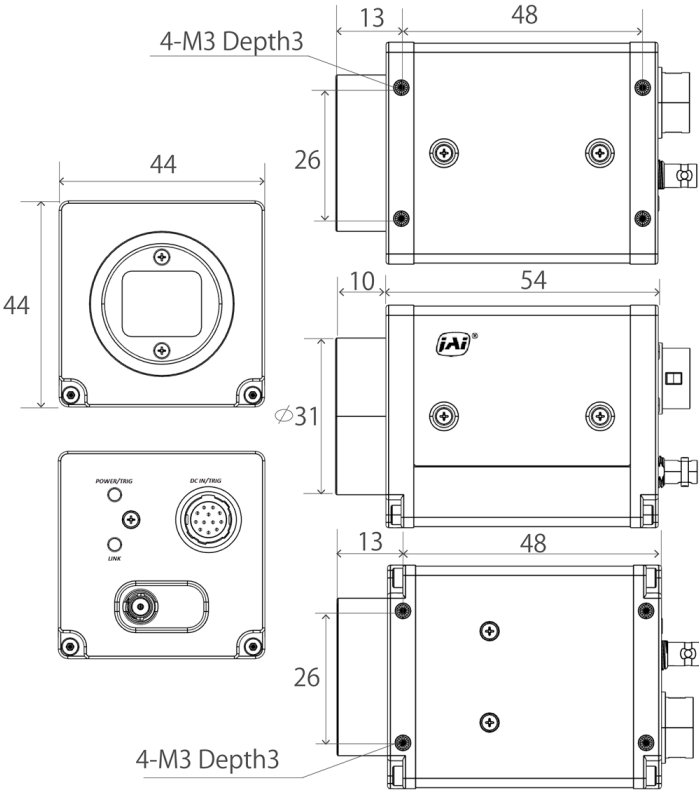

Notes:

- Dimensional tolerance: $\pm 0.3\text{mm}$
- Unit: mm

Comparison of the Decibel Display and Multiplier Display

Decibels (dB)	Multipliers (×)	Remarks
-6	0.501	
-5	0.562	
-4	0.631	
-3	0.708	
-2	0.794	
-1	0.891	
0	1	
1	1.122	
2	1.259	
3	1.413	
4	1.585	
5	1.778	
6	1.995	
7	2.239	
8	2.512	
9	2.818	
10	3.162	
11	3.548	
12	3.981	
13	4.467	
14	5.012	
15	5.623	
16	6.31	
17	7.0790	
18	7.943	
19	8.913	
20	10	
21	11.22	
22	12.589	
23	14.125	
24	15.849	
25	17.783	
26	19.953	
27	22.387	
28	25.119	
29	28.184	
30	31.623	
31	35.481	

Decibels (dB)	Multipliers (×)	Remarks
32	39.811	
33	44.668	
34	50.119	
35	56.235	
36	63.096	

User's Record

Model name:

Revision:

Serial No:

Firmware version:

For camera revision history, please contact your local JAI distributor.

Revision History

Revision	Date	Changes
Preliminary	2024/12/27	