



GIG VISION **GEN<i>i>CAM**



sensor information

sensor	Sony IMX304
resolution	4096 × 3000 px
exposure time	0,001 ... 60000 ms
pixel size	3.45 × 3.45 μm
shutter type	Global shutter
sensor type	1.1" CMOS

acquisition formats

image formats, interface	Full Frame, 4096 × 3000 px, max. 10 fps
frame rate max.	Binning 2×2, 2048 × 1500 px, max. 15 fps Binning 2×1, 2048 × 3000 px, max. 15 fps Binning 1×2, 4096 × 1500 px, max. 15 fps
image formats, acquisition	Full Frame, 4096 × 3000 px, max. 15 fps
frame rate max. (Burst Mode)	
pixel formats	Mono8 Mono10

image preprocessing

analog controls	Gain (0 ... 48 dB) Offset (0 ... 255 LSB 12 Bit)
color models	Mono

interfaces and connectors

data interface	Gigabit Ethernet, Transfer rate 1000 Mbits/sec, Fast Ethernet, Transfer rate 100 Mbits/sec, Connector: M12 / 8 pol x-coded, screwable type
process interface	M12 / 12 pins a-coded (SACC-CI-M12MS-12CON-L180)
power supply	via M12/12 pins a-coded or PoE

mechanical data

lens mount	C-mount
width	40 mm
height	40 mm
depth	51 mm

mechanical data

weight	≤ 137 g
material	aluminum, hard-anodized

electrical data

voltage supply	12 ... 24 V DC (external power supply)
range +Vs	36 ... 57 V DC (Power over Ethernet)
power consumption	approx. 2,5 W @ 12 VDC and 9 fps approx. 3,2 W @ 48 VDC (PoE) and 9 fps

non-volatile memory

flash memory size	128 kB
-------------------	--------

environmental conditions

operating temperature	-40 ... +70 °C @ T = measurement point
humidity	10 ... 90 % (non-condensing)
protection class	IP 40 IP 54 (with mounted tube and cable) IP 65 (with mounted tube and cable) IP 67 (with mounted tube and cable) IP 69K (with stainless steel housing accessory)

digital I/Os

lines	4 input lines 4 output lines with pulse width modulation (PWM) (max. 48 V / max. 2,5 A)
-------	--

conformity

conformity	CE RoHS EAC
------------	-------------------

VCXG-124M.I.XT

Gigabit Ethernet, 12,3 Megapixel, Monochrome

Article number: 11188928

dimension drawing

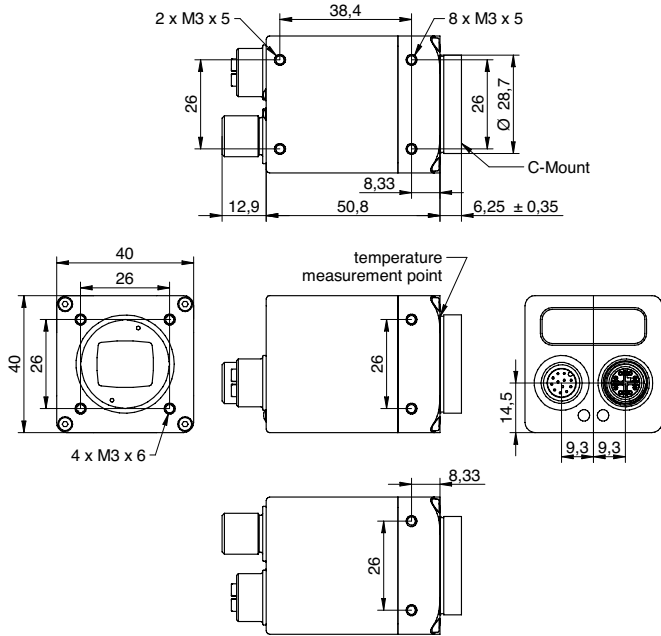

schematic diagram

Optional accessories for protection class IP65/67:

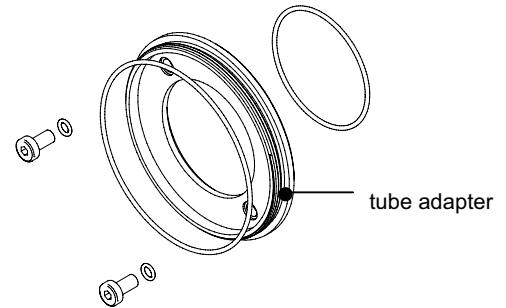

tube adapter

- Ø 49,5 mm, hard-anodized, incl. sealing and screws (VCXG.I 11185373)
- Ø 65 mm, hard-anodized, incl. sealing and screws (VCXG.I 11185377; VLXT 11193125)

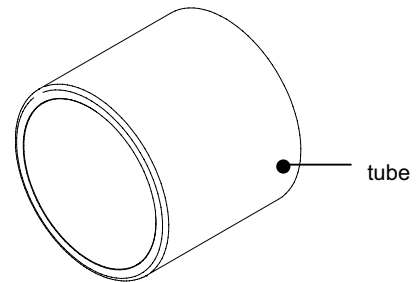

tube

- Ø 49,5 mm, length 44 mm, hard-anodized, cover glass PMMA (11185370)
- Ø 65 mm, length 58 mm, hard-anodized, cover glass PMMA (11185374)
- Ø 49,5 mm, length 44 mm, hard-anodized, tempered laminated safety glass (11195425)
- Ø 65 mm, length 58 mm, hard-anodized, tempered laminated safety glass (11195426)

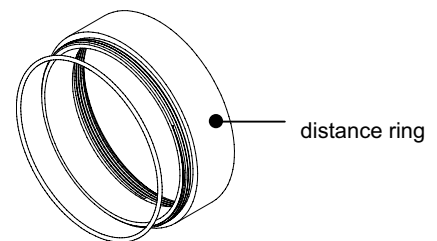

distance ring

- Ø 49,5 mm, length 12 mm, hard-anodized, incl. sealing (11185371)
- Ø 49,5 mm, length 6 mm, hard-anodized, incl. sealing (11185372)
- Ø 65 mm, length 12 mm, hard-anodized, incl. sealing (11185375)
- Ø 65 mm, length 6 mm, hard-anodized, incl. sealing (11185376)
- Ø 65 mm, length 36 mm, hard-anodized, incl. sealing (111988906)